



Multi Control Devices

● Potentiometer Type ————— 2

● Switch Type ————— 7

Potentiometer Type

List of Varieties

Series		RKJXV	RKJX2
Photo			
Dimensions (mm)		17.8×21.3×11.2 18.2×21.7×11.2	13.7×14.6×7.8 (Not including FPC)
Directional resolution		Continuous	
Lever return mechanism		With	
Operating temperature range		-10°C to +70°C	-10°C to +50°C
Operating life (cycles)	Directions	2,000,000	
	Center push	500,000	
Potentiometer part	Maximum operating voltage	5V DC 50V AC, 5V DC	5V DC
	Operating angle	Each direction 23° max.	
	Resistance taper	B	
	Total resistance	10kΩ	5kΩ
Center push part	Center push	With Without	With
	Ratings (max.)	50mA 12V DC	1mA 5V DC
	Travel (mm)	0.4(+0.5, -0.3)	0.35(+0.5, -0.25)
Electrical performance	Insulation resistance	100MΩ min. 250V DC	
	Voltage proof	250V AC for 1 minute	
	Rated power	0.0125W	
	Slider noise	300mV p-p max. by JIS method	
Mechanical performance	Directional operating force	14±10mN·m	7(+5, -3)mN·m
	Push operating force	7.4±3N	6.0±2.5N
	Lever return precision	±5°	
	Actuator strength Push/pull directions	98N min. (Push), 50N min. (Pull)	
Environmental performance	Cold	-30°C 96h	
	Dry heat	80°C 96h	
	Damp heat	60°C, 90 to 95%RH 96h	
Automotive		—	—

Drawing No.2

■ Dimensions

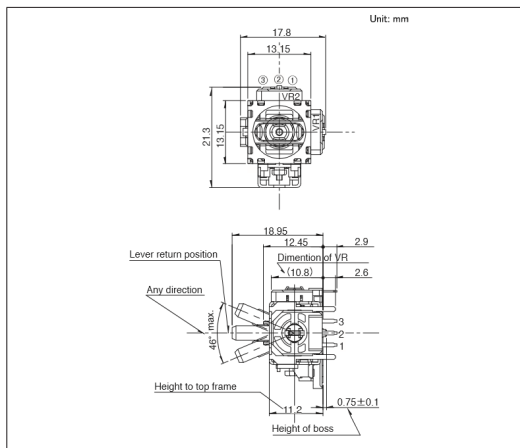

■ Mounting Hole Dimensions

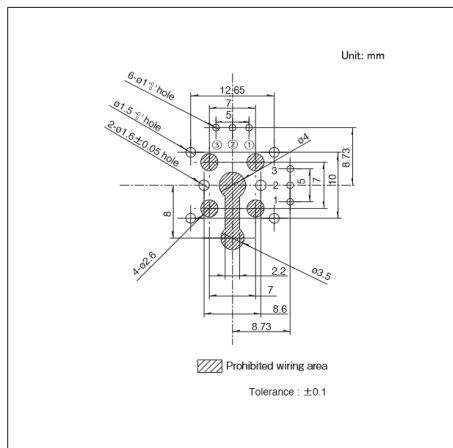

Viewed from mounting side.

Potentiometer Type Multi Control Devices / Soldering Conditions

■ Reference for Manual Soldering

Series	Tip temperature	Soldering time	No. of solders
RKJXV	350°C max.	3s max.	1 time

■ Reference for Dip Soldering

Series	Preheating		Dip soldering		No. of solders
	Soldering surface temperature	Heating time	Soldering temperature	Soldering time	
RKJXV	90 ~ 120°C	60s max.	260°C	5s	1 time

Potentiometer Type Multi Control Devices / Cautions

Circuit Used for Analog Stick Controller

Please use in the voltage adjustment circuit (Fig. A).

Impedance on the Output Side

Since this product is designed to use with its output is connected directly to A/D port. Impedance is considered to be mega ohm level. Then contact resistance in the product is higher. Please refer to Fig-1. So when you use it in the circuit like Fig-2. Please make sure that impedance should be over than 1M-ohm.

Dew Condensation

Avoid using the product when condensation or drops of water might occur inside the product. Otherwise, insulation deterioration or shorting may occur.

Soldering

To avoid potential contact issues, please do not solder wires to the top surface of the printed circuit board as shown in the diagram.

Solder all metal lugs into a substrate before use.

Stress Being Applied to the Terminals

Always be careful not to apply excessive stress on the terminals. Design appropriate soldering conditions.

Handling of Variable Resistors Equipped with Switches

Exercise care when packing or storing. Packaging or storing while load is applied to the shaft may cause a malfunction in performance.

Storage

1. Store the products as delivered, at a normal temperature and humidity, without direct sunshine and corrosive gas ambient. Use them at an earliest possible timing, not later than six months upon receipt.
2. After breaking the seal, keep the products in a plastic bag to shut out ambient air, store them in the same environment as above, and use them up as soon as possible.
3. Do not stack too many switches.

The above operation notes are quoted from the "Precaution and Guideline of Potentiometer for Electrical Devices", which is a technical report issued by the Japan Electronics and Information Technology Industries Association EIAJ RCR-2191A (in March 2002).

For details, see the above technical report.

A.Voltage divider type

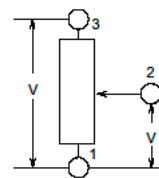

[Fig.1]

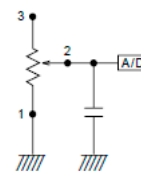



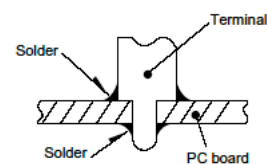
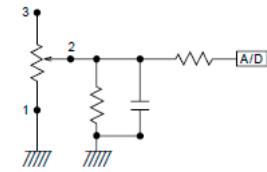



[Fig.2]



Switch Type

List of Varieties

Series		RKJXT1F	RKJXM	SKRH	SRBE	SLLB	SLLB5	
Photo								
Dimensions (mm)		17.0×17.0×10.5	11.0×11.0×6.6	7.35×7.5×1.8 7.45×7.5×1.85	8.05×11×2.35	11.8×11.4×3.0	9.5×8.8×2.2	
Directional resolution		4-direction	8-direction	4-direction	—	2-direction		
Operating temperature range		-40°C to +85°C			-10°C to +60°C	-40°C to +85°C	-10°C to +60°C	
Rating (max.)		10mA 5V DC		50mA 12V DC	1mA 5V DC	10mA 5V DC		
Durability	Operating life	Directions	Total with 4-direction 50,000 cycles	Total with 8-direction 100,000 cycles	—			
		Center push	50,000 cycles	100,000 cycles	200,000 cycles 1,000,000 cycles	100,000 cycles	—	
		Encoder	15,000 cycles	—	100,000 cycles	—	—	
	Operating life without load	—			100,000 cycles			
	Operating life with load (Load: as ratings)	—				100,000 cycles (10mA 5V DC)		
Electrical performance	Insulation resistance	100MΩ min. 250V DC		100MΩ min. 100V DC	10MΩ min. 50V DC	100MΩ min. 100V DC		
	Voltage proof	300V AC for 1 minute or 360V AC for 2s		100V AC for 1 minute	50V AC for 1 minute	100V AC for 1 minute		
Mechanical performance	Directional operating force	40±25mN-m	Direction A, B, C, D 30±20mN-m Direction AB, BC, CD, DA 25±20mN-m	1.2±0.69N 1.23±0.69N	—	0.65±0.3N		
	Push operating force	5±2N	3±1.5N	2.35±0.69N	3.5±1.5N	2±1N	2.5±1N	
	Actuator strength	Push/pull directions	100N (Push/Pull)	100N (Push), 50N (Pull)	—	50N		
Operating direction		0.4N-m	0.3N-m	29.4N	—	10N		
Environmental performance	Cold	-40°C 500h		-40°C 96h	-30°C 96h	-40°C 96h	-20°C 96h	
	Dry heat	85°C 500h		90°C 96h	85°C 96h			
	Damp heat	60°C, 90 to 95%RH 500h		60°C, 90 to 95%RH 96h	40°C, 90 to 95%RH 96h			
Automotive		●	●	—	—	—	—	

⚠ Note

● Indicates applicability to all products in the series, while ○ indicates applicability to some products in the series.

Multi Control Devices **Switch Type**

4-directional Stick Switch (with Encoder + Center-push Function)
RKJXT1F Series

Automotive-compatible multifunctional device with a 17×17mm round body, offering 1-axis 4-direction/push/encoder functions.



- Directional resolution: 4-direction
- Ratings (max.) (Resistive load): 10mA 5V DC
- Operating temperature range: -40°C to +85°C

Applications: Audio_TV: Visual
 Automotive: Navigation/audio systems, HVAC

■ Product List

Products No.	Stick switches		Encoder		Dimensions (W×D×H) (mm)	Automotive	Drawing No.
	Operating angle (Directions)	Travel (Center push) (mm)	Number of detent	Number of pulse			
RKJXT1F42001	Each direction 9°max.	0.3±0.2	30	15	17.0×17.0×10.5	●	1

⚠ Note

1. This catalog shows only outline specifications. When using the products, please obtain formal specifications for supply.
2. Please place purchase orders per minimum order unit (integer).

■ Packing Specifications

Tray

Number of packages (pcs.)		Export package measurements (mm)
1 case / Japan	1 case / export packing	
1,320	2,640	555×375×333

Drawing No.1

■ Dimensions

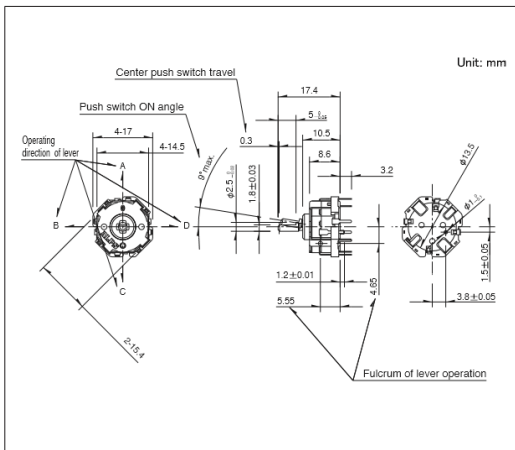

■ Mounting Hole Dimensions

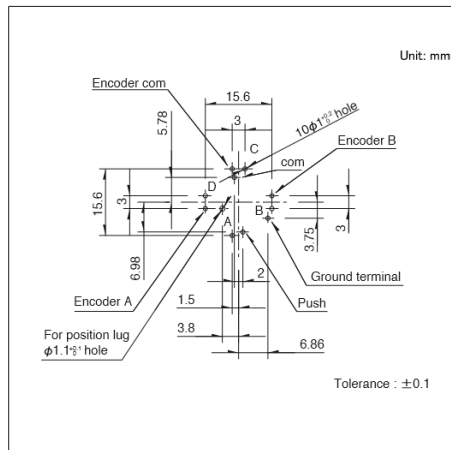

Viewed from mounting side.

■ Circuit Diagram

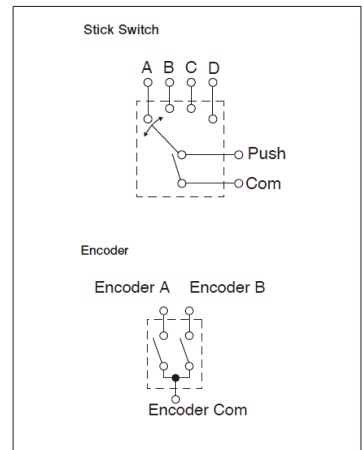

Multi Control Devices **Switch Type**

8-direction Stick Switch (with Center-push Function)
RKJXM Series

Automotive-compatible multifunctional switch with an 11×11mm round body, offering 1-axis 8-direction operation with tactile feedback.



Automotive

- Directional resolution: 8-direction
- Ratings (max.) (Resistive load): 10mA 5V DC
- Operating temperature range: -40°C to +85°C

Applications: Audio_TV: Visual
 Automotive: Navigation/audio systems, HVAC

■ Product List

Products No.	Operating angle (Directions)	Travel (Center push) (mm)	Dimensions (W×D×H) (mm)	Automotive	Drawing No.
RKJXM1015004	A, B, C, D direction: 10°max. AB, BC, CD, DA direction: 12°max.	0.3±0.2	11.0×11.0×6.6	●	1

Note

1. This catalog shows only outline specifications. When using the products, please obtain formal specifications for supply.
2. Please place purchase orders per minimum order unit (integer).

■ Packing Specifications

Tray

Number of packages (pcs.)		Export package measurements (mm)
1 case / Japan	1 case / export packing	
1,000	2,000	405×290×200

Drawing No. 1

■ Dimensions

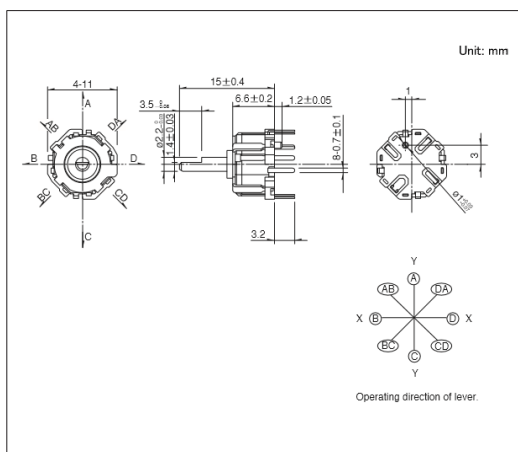

■ Mounting Hole Dimensions

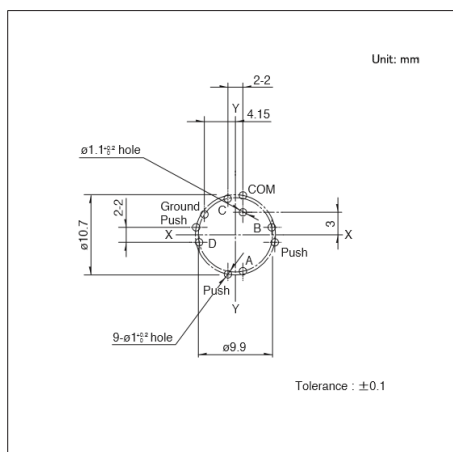

■ Circuit Diagram

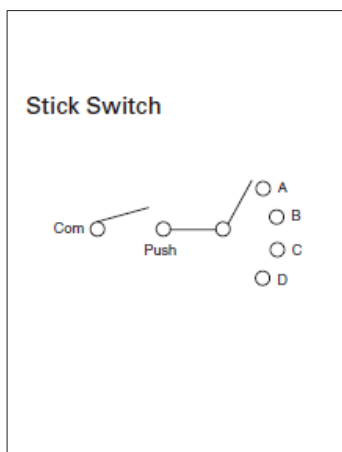

Viewed from mounting side.

Multi Control Devices **Switch Type**

4-direction Type with Center-push Function (Surface Mount)

SKRH Series

Body thickness of 1.85mm with a long-life rating of 1 million cycles.



- Directional resolution: 4-direction
- Ratings (max.)/(min.) (Resistive load): 50mA 12V DC/10μA 1V DC
- Operating temperature range: -40°C to +85°C

Applications: Game: Home handheld consoles, Virtual/augmented reality

■ Product List

Products No.	Operating force		Travel		Operating life (5mA 5V DC) (cycles)	Initial contact resistance	Stem color	Guide bosses	Dimensions (W×D×H) (mm)	Automotive	Drawing No.
	4-direction (N)	Center push (N)	4-direction (mm)	Center push (mm)							
SKRHAAE010	1.23	2.35	0.25	0.15	200,000 for each direction	500mΩ max.	Black	Without	7.35×7.5×1.8	—	1
SKRHABE010	1.23	2.35	0.25	0.15	200,000 for each direction	500mΩ max.	Black	With	7.35×7.5×1.8	—	2
SKRHACE010	1.2	2.35	0.25	0.15	1,000,000 for each direction	100mΩ max.	Natural	Without	7.45×7.5×1.85	—	3
SKRHAE010	1.2	2.35	0.25	0.15	1,000,000 for each direction	100mΩ max.	Natural	With	7.45×7.5×1.85	—	4

⚠ Note

1. This catalog shows only outline specifications. When using the products, please obtain formal specifications for supply.
2. 4-directional operating force and travel are measured at 4.3mm height from the bottom of the switch.
3. Please place purchase orders for taping products per minimum order unit (1 reel or a case).

■ Packing Specifications

Taping

Number of packages (pcs.)			Tape width (mm)	Export package measurements (mm)
1 reel	1 case / Japan	1 case / export packing		
1,300	10,400	10,400	16	395×395×205

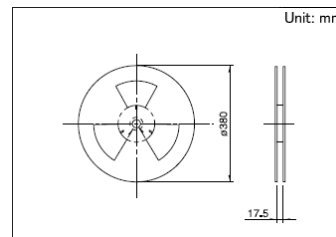

Drawing No. 1

■ Dimensions

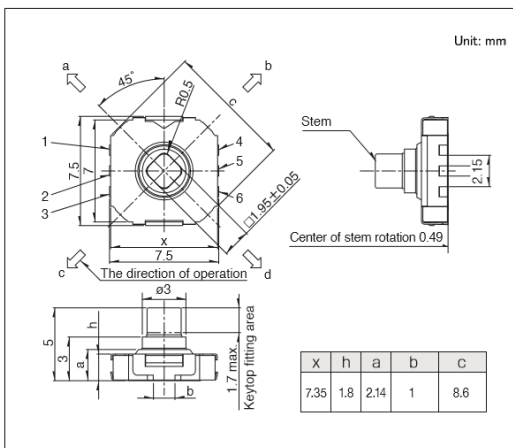

■ Land Dimensions

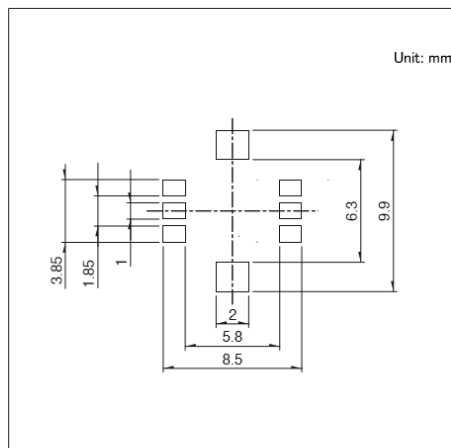

■ Circuit Diagram

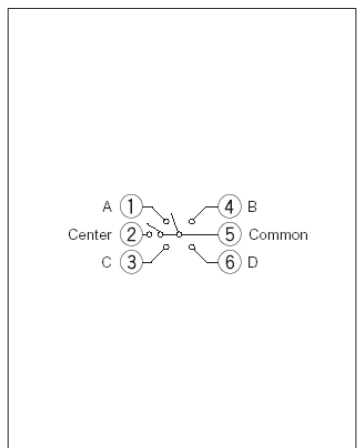

Viewed from mounting face.

4-direction Type with Center-push Function (Surface Mount)
SKRH Series

Drawing No.2

■ Dimensions

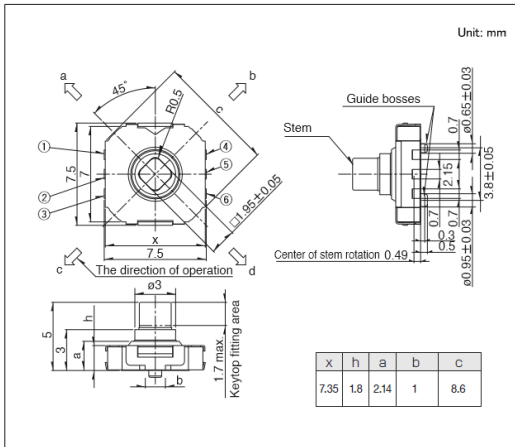

■ Land Dimensions

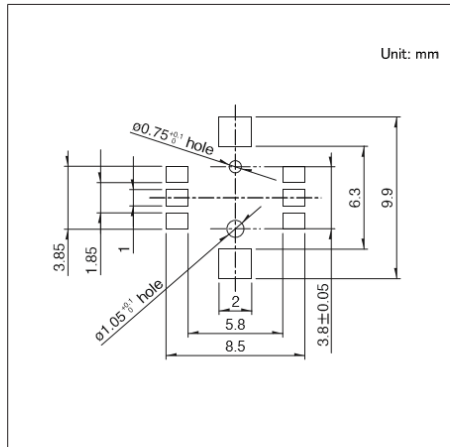

■ Circuit Diagram

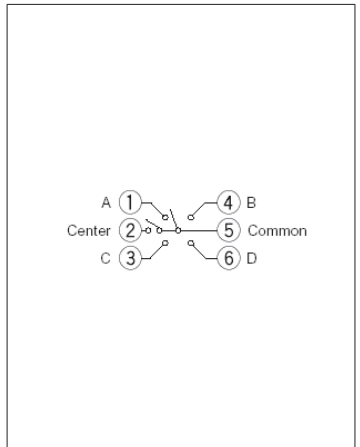

Viewed from mounting face.

Drawing No.3

■ Dimensions

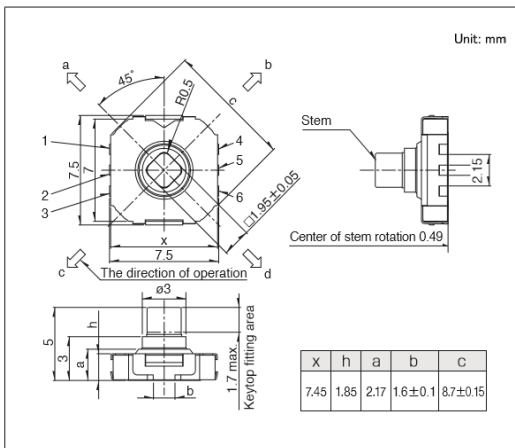

■ Land Dimensions

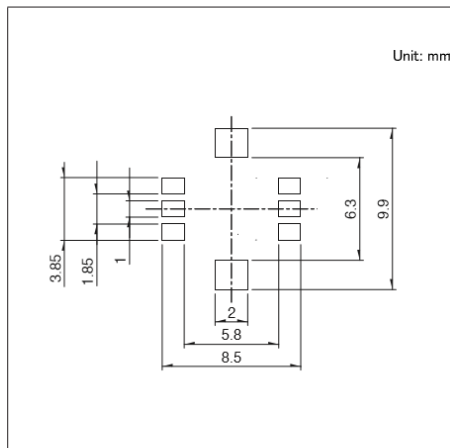

■ Circuit Diagram

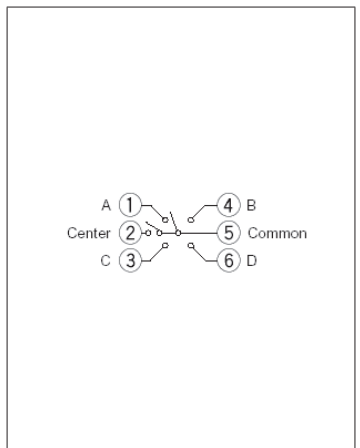

Viewed from mounting face.

Drawing No.4

■ Dimensions

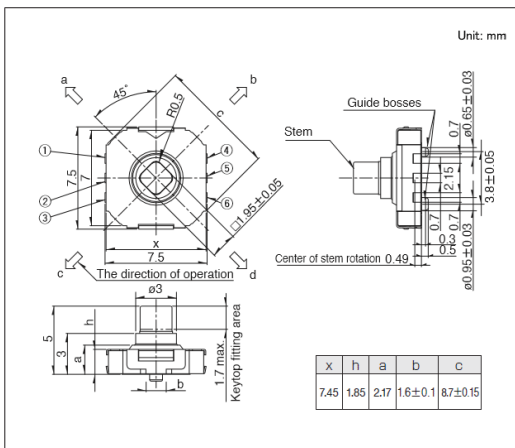

■ Land Dimensions

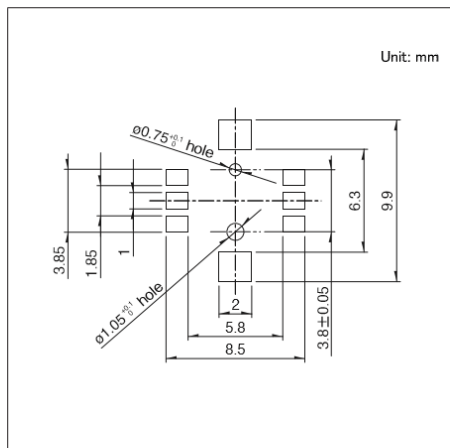

■ Circuit Diagram

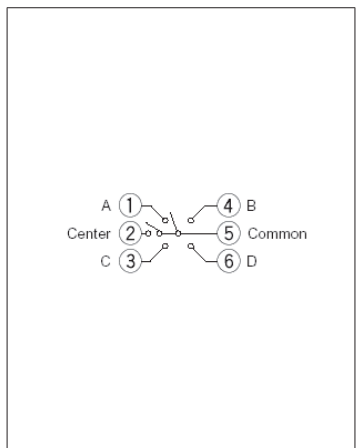

Viewed from mounting face.

Multi Control Devices **Switch Type**

Encoder and Push Operation Type
SRBE Series

Compact, multifunctional operation device utilizing side space of the set.

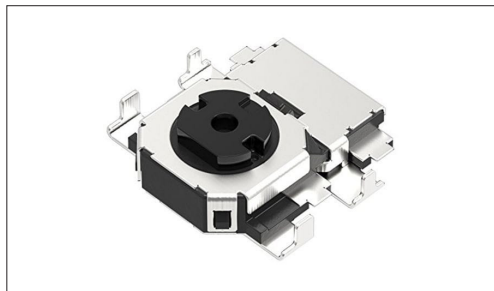

- Directional resolution:-
- Ratings (max.)/(min.) (Resistive load): 1mA 5V DC/50μA 3V DC
- Operating temperature range:-10°C to +60°C

Applications: Game: Home handheld consoles, Virtual/augmented reality

■ Product List

Products No.	Number of detent	Number of pulse	Operating direction	Mounting method	Travel (Push operation)	Dimensions (W×D×H) (mm)	Automotive	Drawing No.
SRBE110301	12	6	Horizontal	Standard	0.2mm	8.05×11×2.35	—	1
SRBE210200	12	6	Horizontal	Low-profile	0.2mm	8.05×11×2.35	—	2

⚠ Note

1. This catalog shows only outline specifications. When using the products, please obtain formal specifications for supply.
2. Please place purchase orders for taping products per minimum order unit (1 reel or a case).

■ Packing Specifications

Taping

Number of packages (pcs.)			Tape width (mm)	Export package measurements (mm)
1 reel	1 case / Japan	1 case / export packing		
1,500	3,000	6,000	24	428×413×172

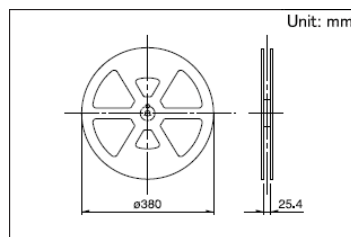

Drawing No.1

■ Dimensions

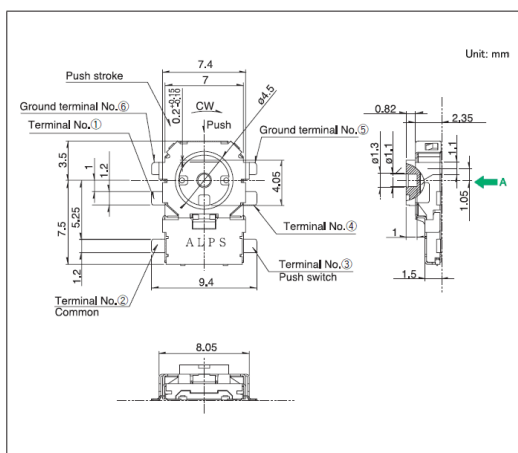

■ Land Dimensions

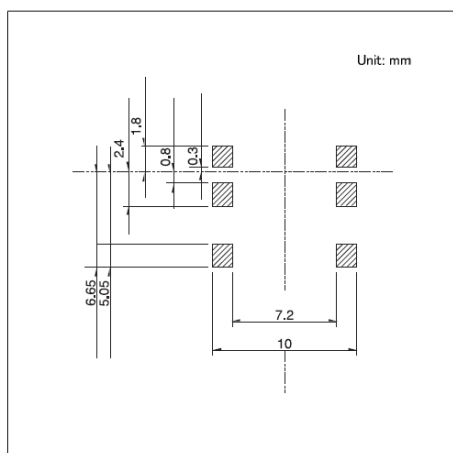

■ Circuit Diagram

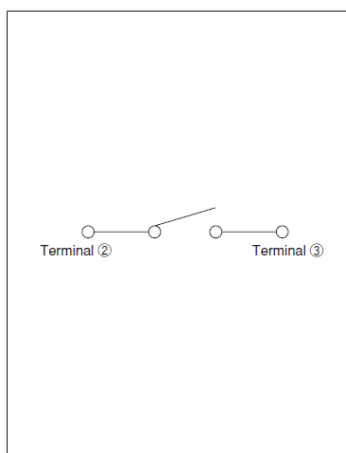

Viewed from direction A in the dimensions.

Drawing No.2

■ Dimensions

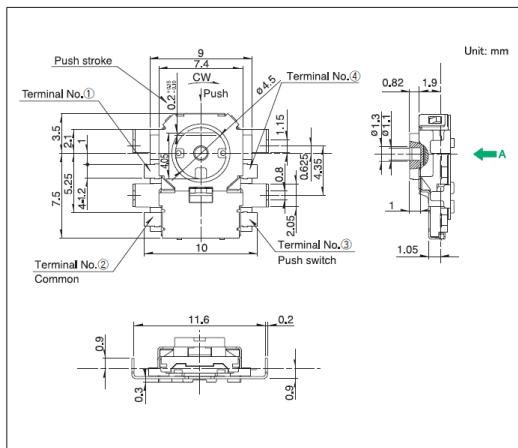

■ Land Dimensions

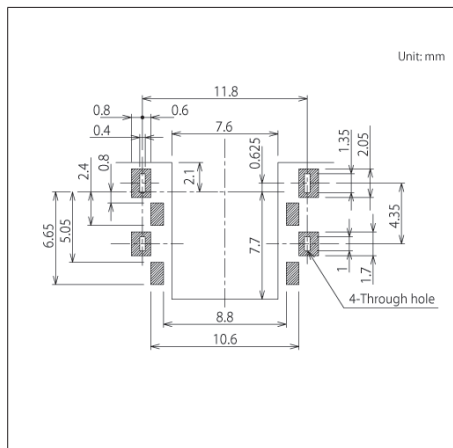

■ Circuit Diagram

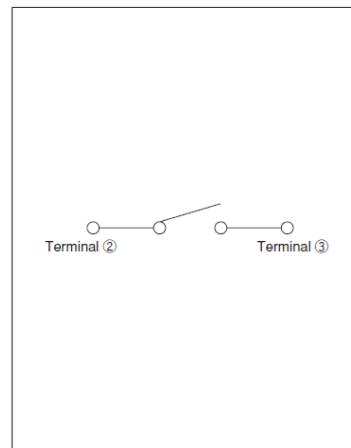

Viewed from direction A in the dimensions.

Multi Control Devices **Switch Type**

Lever and Push Operation Type
SLLB Series

Compact, thin-profile horizontal type suitable for a wide range of applications.

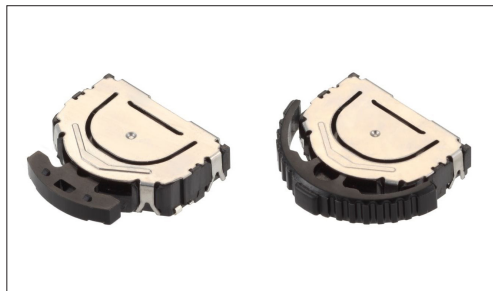

- Directional resolution: 2-direction
- Ratings (max.)/(min.) (Resistive load): 10mA 5V DC/50μA 3V DC
- Operating temperature range: -40°C to +85°C

Applications: Audio_TV:Cameras

■ Product List

Products No.	Actuator configuration	Push-on switch	Operating force		Travel (Center push) (mm)	Location lug	Dimensions (W×D×H) (mm)	Automotive	Drawing No.
			Lever portion	Push portion					
SLLB120100	Mounting knob	With	0.65±0.3N	2±1N	Refer to the dimensions	With	11.8×11.4×3.0	—	1
SLLB120200	Mounting knob integrated	With	0.65±0.3N	2±1N	Refer to the dimensions	With	11.8×11.4×3.0	—	2
SLLB120300	Mounting knob integrated	With	0.65±0.3N	2±1N	Refer to the dimensions	With	11.8×11.4×3.0	—	

⚠ Note

1. This catalog shows only outline specifications. When using the products, please obtain formal specifications for supply.
2. Please place purchase orders for taping products per minimum order unit (1 reel or a case).

■ Packing Specifications

Taping

Number of packages (pcs.)			Tape width (mm)	Export package measurements (mm)
1 reel	1 case / Japan	1 case / export packing		
1,350	2,700	5,400	24	428×413×172

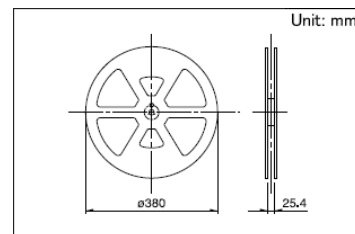

Drawing No. 1

■ Dimensions

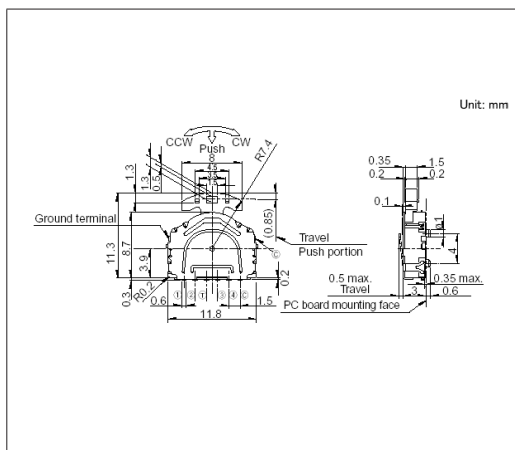

■ Land Dimensions

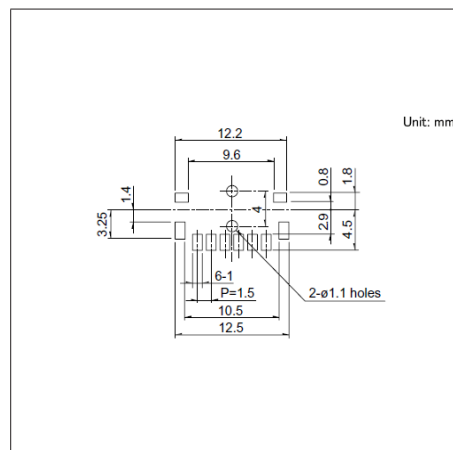

Viewed from mounting face.

■ Circuit Diagram

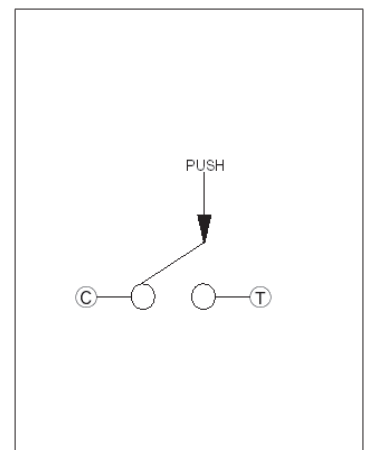

Push portion.

Multi Control Devices **Switch Type**

Lever and Push Operation Type
SLLB5 Series

Two-direction input device reduced to 50% of the projected area compared to conventional products.



- Directional resolution: 2-direction
- Ratings (max.)/(min.) (Resistive load): 10mA 5V DC/50μA 3V DC
- Operating temperature range: -10°C to +60°C

Applications: Audio_TV:Cameras

■ Product List

Products No.	Actuator configuration	Push-on switch	Operating force		Travel (Center push) (mm)	Location lug	Dimensions (W×D×H) (mm)	Automotive	Drawing No.
			Lever portion	Push portion					
SLLB510100	Mounting knob integrated	With	0.65±0.3N	2.5±1N	0.7	With	9.5×8.8×2.2	—	1
SLLB510200	Mounting knob integrated	With	0.65±0.3N	2.5±1N	0.7	Without	9.5×8.8×2.2	—	2
SLLB520100	Mounting knob	With	0.65±0.3N	2.5±1N	0.7	With	9.5×8.8×2.2	—	3
SLLB520200	Mounting knob	With	0.65±0.3N	2.5±1N	0.7	Without	9.5×8.8×2.2	—	4

⚠ Note

1. This catalog shows only outline specifications. When using the products, please obtain formal specifications for supply.
2. Please place purchase orders for taping products per minimum order unit (1 reel or a case).

■ Packing Specifications

Taping

Number of packages (pcs.)			Tape width (mm)	Export package measurements (mm)
1 reel	1 case / Japan	1 case / export packing		
1,500	3,000	6,000	24	428×413×172

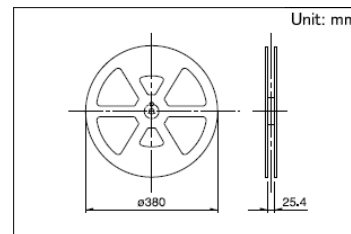

Drawing No.1

■ Dimensions

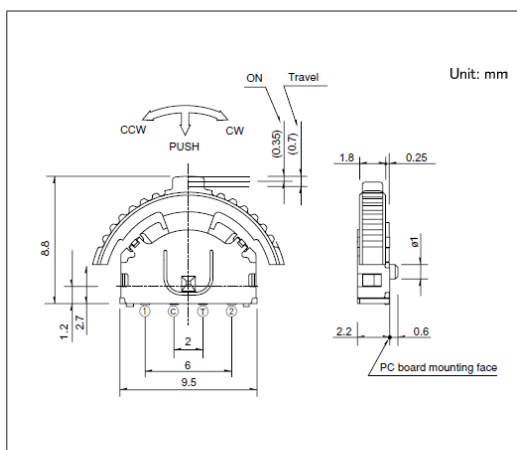

■ Land Dimensions

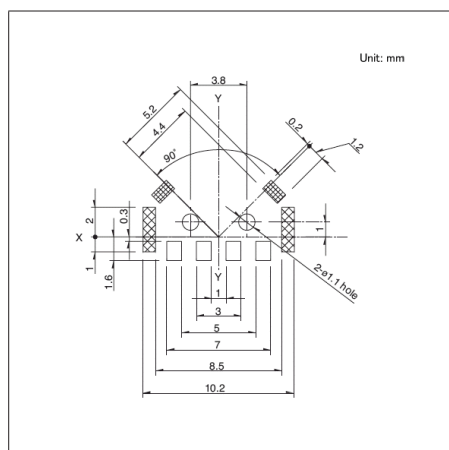

Viewed from mounting face.

■ Circuit Diagram

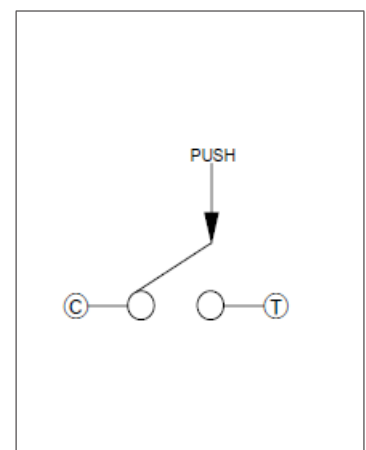

Push portion.

Lever and Push Operation Type
SLLB5 Series

Drawing No.2

■ Dimensions

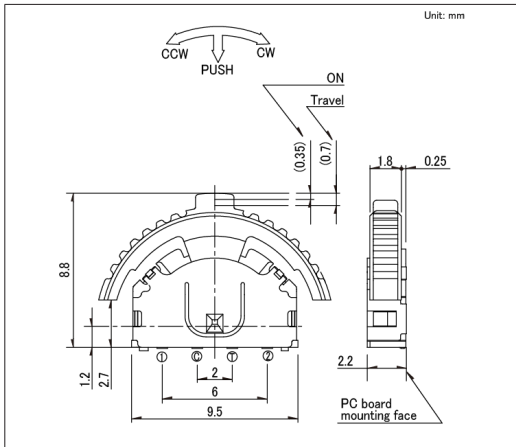

■ Land Dimensions

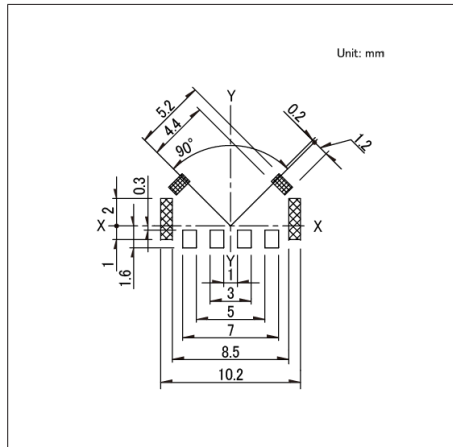

■ Circuit Diagram

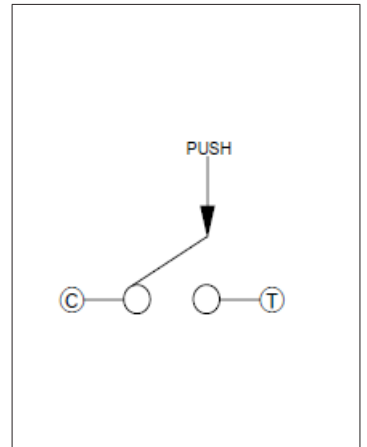

Viewed from mounting face.

Push portion.

Drawing No.3

■ Dimensions

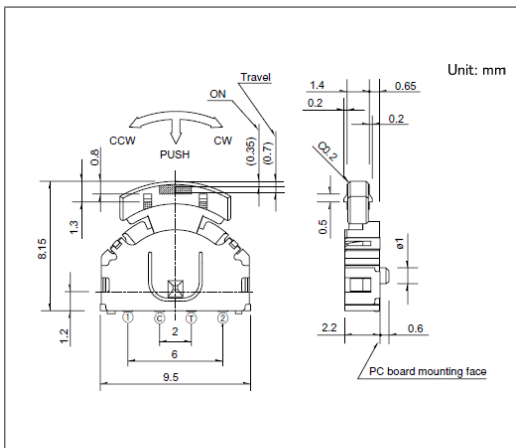

■ Land Dimensions

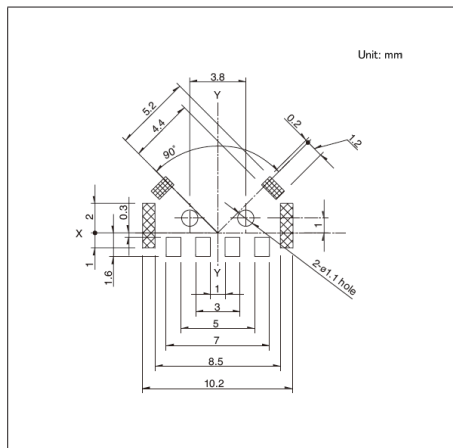

■ Circuit Diagram

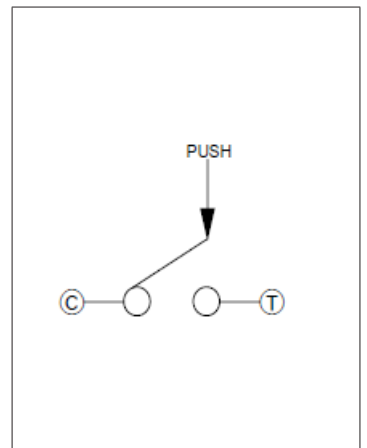

Viewed from mounting face.

Push portion.

Drawing No.4

■ Dimensions

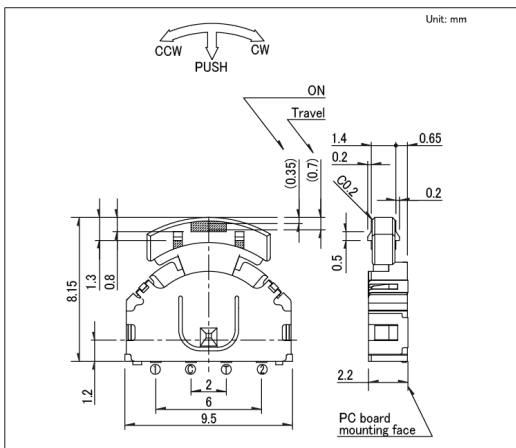

■ Land Dimensions

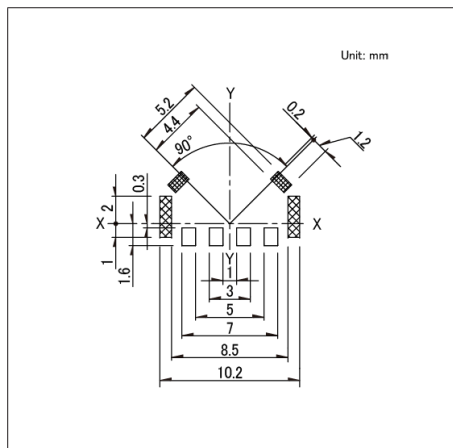

■ Circuit Diagram

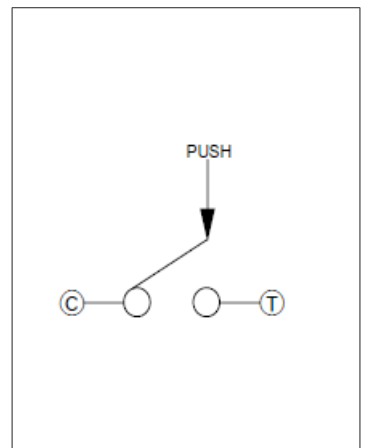

Viewed from mounting face.

Push portion.

Switch Type Multi Control Devices / Soldering Conditions

■ Reference for Manual Soldering

Series	Tip temperature	Soldering time	No. of solders
RKJXT1F, RKJXM, SLLB, SLLB5, SRBE, SKRH	350±5℃	3s max.	1 time

■ Reference for Dip Soldering

Series	Preheating		Dip soldering		No. of solders
	Soldering surface temperature	Heating time	Soldering temperature	Soldering time	
RKJXT1F, RKJXM	100℃ max.	2 min. max.	260±5℃	5±1s	2 time max.

■ Example of Reflow Soldering Condition

1. Heating method: Double heating method with infrared heater.
2. Temperature measurement: Thermocouple ϕ 0.1 to 0.2 CA (K) or CC (T) at soldering portion (copper foil surface).
A heat resisting tape should be used for fixed measurement.
3. Temperature profile

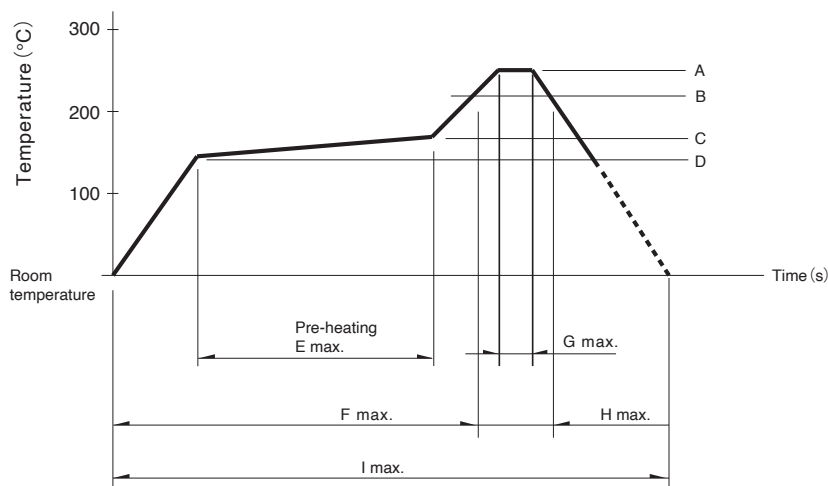

Series	A	B	C	D	E	F	G	H	I	No. of reflows
SLLB5	250℃	230℃	150℃	150℃	—	2 min.	—	30s	—	1 time
SKRH, SLLB, SRBE	260℃	230℃	180℃	150℃	2 min.	—	—	40s	—	1 time

⚠ Note

1. The above temperature shall be measured on the mounting surface of a PC board. There are cases where the PC board's temperature greatly differs from that of the switch, depending on the material, size thickness of PC boards and others. The above-stated conditions shall also apply to switch surface temperatures.
2. Soldering conditions differ depending on reflow soldering machines. Prior verification of soldering condition is highly recommended.

Switch Type Multi Control Devices / Cautions

1. Applying load to terminals during soldering under certain conditions may cause deformation and electrical property degradation.
2. Avoid use of water-soluble soldering flux, since it may corrode the switches.
3. Check and conform to soldering requirements under actual mass production conditions.
4. In soldering twice, make sure the solder joints should go down to normal temperature. Continuing heating will cause deformation of switch, loose and fractured terminals, or may deteriorate electrical characteristics.
5. Flux from around and above the PC board should not adhere to the switches.
6. For the sizes of holes and patterns on a PC board for mounting a switch, refer to the recommended dimensions in the outline drawings.
7. This switch is designed for manually operated units. Must not use this switch for a mechanical detection unit. For detection purposes, please use our detection switches.
8. After mounting the switches, if you intend to put the board into an oven in order to harden adhesive for other parts, please consult with ALPS.
9. Use of a through-hole PC board, or a PC board of different thickness from the recommendation will have a different heat stress. Verify the soldering requirements thoroughly before use.
10. Solder the switches with detent at the detent position. Soldering switches fixed at the center of the detent may deform the detent mechanisms.
11. No washing.
12. Protect small and thin switches from external forces in the set mounting process.
13. Use of the switches with voltage below 1V DC or current below $10\mu A$ may make contacts unstable.
When using these switches in this way, please consult with us beforehand.
14. The products are designed and manufactured for direct current resistance. Contact us for use of other resistances such as inductive (L) or capacitive (C).
15. The switch will be broken if impact force or a greater stress than that specified is applied. Take a great care not to let the switch be subject to greater stress than specified.
16. Do not apply a force from the side of the stem.
17. Be sure to push the center of switch for "without-stem" type. Extreme care is required for a hinge structure type because the stem press position moves when it is pressed.
18. Insert these switches to the specified mounting surface and mount them horizontally. If not mounted horizontally, these switches will malfunction.
19. Use of the switches in a dusty environment may lead the dusts entering through the openings and cause imperfect contact or malfunction. Take this into account for set design.
20. Corrosive gas if generated by peripheral parts of a set, malfunction such as imperfect contact may occur. Thorough investigation shall be required beforehand.
21. Be aware of dust intrusion into a non dust-proof-type TACT Switch™.
22. Storage
 1. Store the products as delivered, at a normal temperature and humidity, without direct sunshine and corrosive gas ambient. Use them at an earliest possible timing, not later than six months upon receipt.
 2. Store the key switches with the switch in the released position.