







Switches

Push Switches





List of Varieties

Series		SPPJ3	SPPJ2	SPUJ	SPUN	SPEJ	SPPH4	SPPH1	
Photo									
Dimensions (mm)		12.0×5.0×8.3 12.0×6.6×8.3	12.0×7.2×9.6 14.0×17.7×9.6	15.2×7.5×8.8	24.0×10.0×13.0	7.0×7.0×5.95	8.5×6.5×8.5	10.0×10.0×8.5	
Travel (mm)		2.5		2.0	2.5	—	2.2	1.5	
Total travel (mm)		3.5		3.0	3.5	1.7	3.0	2.5	
Poles		1 2	2	2 4		2			
Operating force		2.3 ±1N 3.3 ±1N	3 ±1.5N	1.5 ±1N 2.3 ±1N	2 ±1N 2.5 ±1N 3 ±1.5N 4 ±2N	3.5 ±0.7N	2 ±1N	2 (+1, -0.7)N 3 (+1, -0.7)N	
Operating temperature range		-40°C to +85°C		-10°C to +60°C		-40°C to +85°C	-10°C to +60°C		
Rating (max.)/(min.) (Resistive load)		0.2A 30V DC/50μA 3V DC		0.1A 30V DC/ 50μA 3V DC	0.1A 30V DC/ 50μA 3V DC 1A 25V DC/ -	0.2A 14V DC/ -	0.1A 30V DC/50μA 3V DC		
Electrical performance	Contact resistance (Initial performance/ After lifetime)	20mΩ max./40mΩ max.				150mΩ max./ 150mΩ max.	100mΩ max. (Initial performance)	20mΩ max./ 40mΩ max.	
	Insulation resistance	100MΩ min. 500V DC							
	Voltage proof	500V AC for 1 minute							
Mechanical performance	Terminal strength	5N for 1 minute				—	5N for 1 minute		
	Actuator strength	Operating direction	50N	30N	50N	49N	30N	50N	
		Pulling direction	—		50N	—	10N	—	
Durability	Operating life without load	10,000 cycles 40mΩ max.			10,000 cycles 40mΩ max. 30,000 cycles 40mΩ max.	10,000 cycles 150mΩ max.	10,000 cycles 100mΩ max.	10,000 cycles 40mΩ max.	
	Operating life with load (at max. rated load)	10,000 cycles 40mΩ max.			5,000 cycles 40mΩ max. 10,000 cycles 40mΩ max.	10,000 cycles 150mΩ max.	10,000 cycles 100mΩ max.	10,000 cycles 40mΩ max.	
Environmental performance	Cold	-40°C 96h	-20°C 96h			-40°C 500h	-20°C 96h		
	Dry heat	85°C 96h				85°C 500h	85°C 96h		
	Damp heat	40°C, 90 to 95%RH 96h				60°C, 90 to 95%RH 500h	40°C, 90 to 95%RH 96h		
Automotive		●	●	—	—	●	—	●	

 Note

● Indicates applicability to all products in the series, while ○ indicates applicability to some products in the series.

Push Switches

Series		SPEF	SPED2	SPED3	SPED4
Photo					
Dimensions (mm)		9.4×9.0×6.9	16.8×14.0×9.5	18.0×14.0×7.4	18.0×14.0×7.27
Travel (mm)		1.5	—		
Total travel (mm)		2.7	4.5	3.8	
Poles		1	1 2	1	
Operating force		3 N 5 N	4.17 ±0.74N		
Operating temperature range		-40°C to +85°C		-40°C to +95°C	
Rating (max.)/(min.) (Resistive load)		1A 14.5V DC/ 50μA 3V DC	1A 14.5V DC/ -	2A 14.5V DC/ -	
Electrical performance	Contact resistance (Initial performance/ After lifetime)	100mΩ max./ 1Ω max.	100mΩ max./100mΩ max.		
	Insulation resistance	3MΩ min. 100V DC	3MΩ min. 500V DC		
	Voltage proof	100V AC for 1 minute			
Mechanical performance	Terminal strength	—			
	Actuator strength	Operating direction	90N	98N	90N
		Pulling direction	30N	—	
Durability	Operating life without load	—			
	Operating life with load (at max. rated load)	30,000 cycles 100mΩ max.			
Environmental performance	Cold	-40°C 96h			
	Dry heat	85°C 96h	85°C 96h 105°C 192h	105°C 192h	
	Damp heat	40°C, 90 to 95%RH 96h			
Automotive		●	●	●	●

⚠ Note

● Indicates applicability to all products in the series, while ○ indicates applicability to some products in the series.

2.5mm-travel Compact-sized Horizontal Type SPPJ3 Series

Compact type with a lever height of 4.7mm.

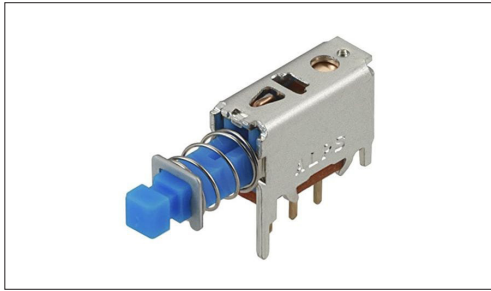

 Automotive

- Rating (max.)/(min.) (Resistive load): 0.2A 30V DC/50 μ A 3V DC
- Contact resistance (Initial performance/After lifetime):
20m Ω max./40m Ω max.
- Operating life without load: 10,000 cycles 40m Ω max.
- Operating life with load (at max. rated load): 10,000 cycles 40m Ω max.

Applications: Healthcare: Healthcare equipment
Automotive: Navigation/audio systems, HVAC

Product List

Products No.	Travel (mm)	Total travel (mm)	Poles	Operating force	Changeover timing	Mounting method	Operation	Terminal type	Dimensions (W×D×H) (mm)	Automotive	Drawing No.
SPPJ310500	2.5	3.5	1	2.3±1N	Non shorting	PC board	Latching	For PC board	12.0×5.0×8.3	●	1
SPPJ311500	2.5	3.5	1	2.3±1N	Non shorting	PC board	Momentary	For PC board	12.0×5.0×8.3	●	
SPPJ320600	2.5	3.5	2	3.3±1N	Non shorting	PC board	Latching	For PC board	12.0×6.6×8.3	●	2
SPPJ322300	2.5	3.5	2	3.3±1N	Non shorting	PC board	Momentary	For PC board	12.0×6.6×8.3	●	

Note

1. This catalog shows only outline specifications. When using the products, please obtain formal specifications for supply.
2. Please place purchase orders per minimum order unit (integer).
3. This products can be used in vehicles.
Although these products are designed to perform over a wide operating temperature range, please ensure that you receive and read the formal delivery specifications before use.
4. The SPPJ3 series should be operated in the direction of the arrow 2 as shown in the following figure and used within an angle of 15° in reference to the center. If an excessive force is applied from the direction of the arrow 1 against the lever, it might fall as illustrated, resulting in malfunction.

Packing Specifications

Bulk

Number of packages (pcs.)		Export package measurements (mm)
1 case / Japan	1 case / export packing	
900	4,500	400 x 270 x 290

2.5mm-travel Compact-sized Horizontal Type
SPPJ3 Series

Drawing No.1

■ Dimensions

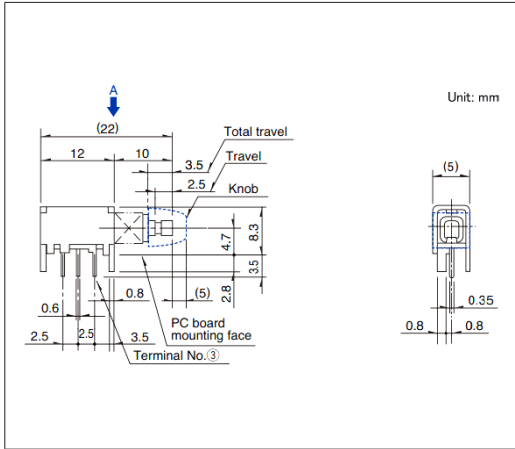

■ Mounting Hole Dimensions

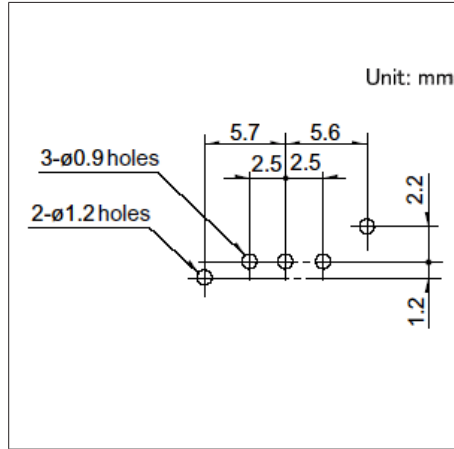

■ Circuit Diagram

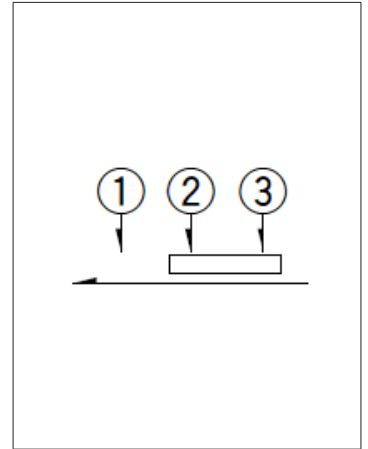

Viewed from direction A in the dimensions.

Drawing No.2

■ Dimensions

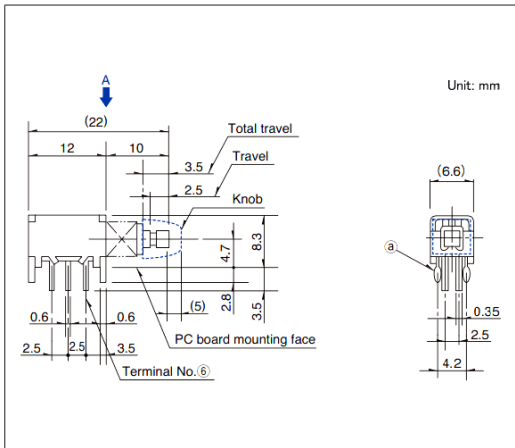

■ Mounting Hole Dimensions

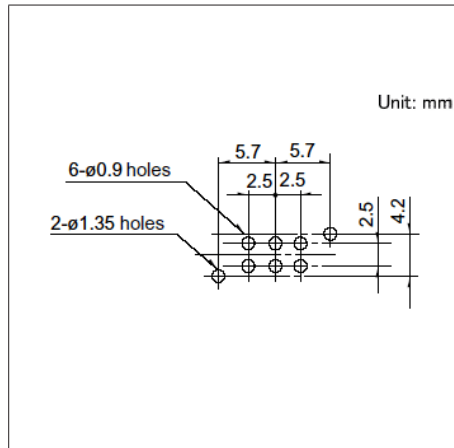

■ Circuit Diagram

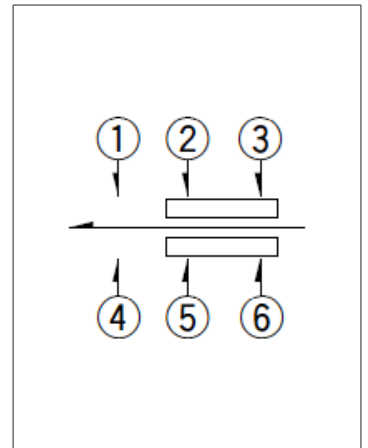

Viewed from direction A in the dimensions.

Switches Push Switches

2.5mm-travel Horizontal Type
SPPJ2 Series

Lever height of 5.5mm, mountable directly on panels.

Automotive

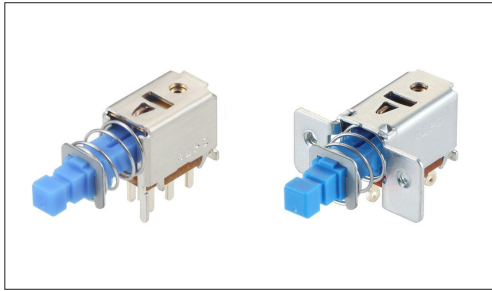

- Rating (max.)/(min.) (Resistive load): 0.2A 30V DC/50μA 3V DC
- Contact resistance (Initial performance/After lifetime):
20mΩ max./40mΩ max.
- Operating life without load: 10,000 cycles 40mΩ max.
- Operating life with load (at max. rated load): 10,000 cycles 40mΩ max.

Applications: Automotive: Navigation/audio systems, HVAC

■ Product List

Products No.	Travel (mm)	Total travel (mm)	Poles	Operating force	Changeover timing	Mounting method	Operation	Terminal type	Dimensions (W×D×H) (mm)	Automotive	Drawing No.
SPPJ222200	2.5	3.5	2	3±1.5N	Non shorting	PC board	Latching	For PC board	12.0×7.2×9.6	●	1
SPPJ223200	2.5	3.5	2	3±1.5N	Non shorting	PC board	Momentary	For PC board	12.0×7.2×9.6	●	
SPPJ225800	2.5	3.5	2	3±1.5N	Non shorting	M2-screw	Latching	Lead	14.0×17.7×9.6	●	2
SPPJ226400	2.5	3.5	2	3±1.5N	Non shorting	M2-screw	Momentary	Lead	14.0×17.7×9.6	●	

Note

1. This catalog shows only outline specifications. When using the products, please obtain formal specifications for supply.
2. Please place purchase orders per minimum order unit (integer).
3. This products can be used in vehicles.
Although these products are designed to perform over a wide operating temperature range, please ensure that you receive and read the formal delivery specifications before use.

■ Packing Specifications

Bulk

Products No.	Number of packages(pcs.)		Export package measurements (mm)
	1 case / Japan	1 case / export packing	
SPPJ222200 SPPJ223200	700	3,500	400 x 270 x 290
SPPJ225800 SPPJ226400	500	2,500	400 x 270 x 290

Drawing No.1

■ Dimensions

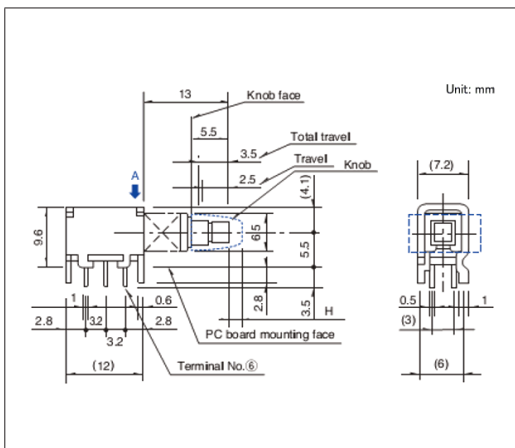

■ Mounting Hole Dimensions

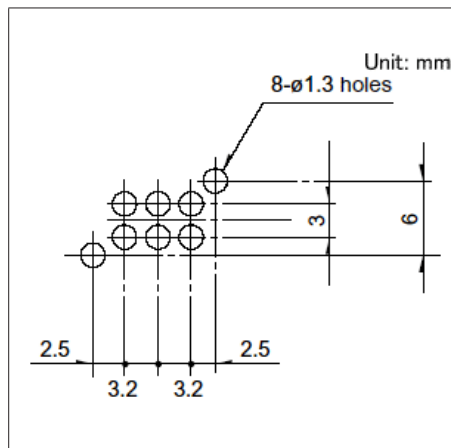

■ Circuit Diagram

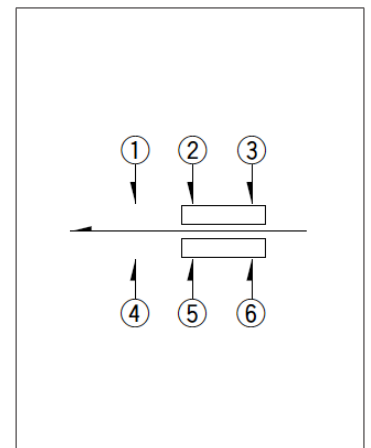

Viewed from direction A in the dimensions.

2.5mm-travel Horizontal Type
SPPJ2 Series

Drawing No.2

■ Dimensions

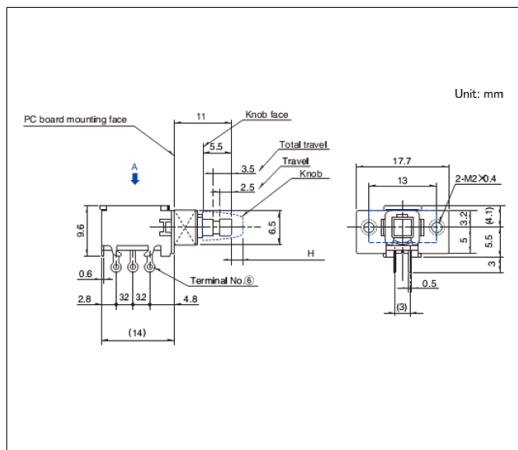

■ Circuit Diagram

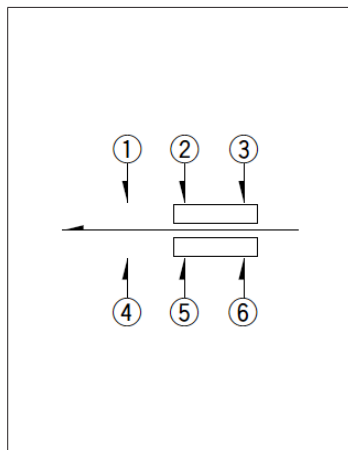

2.0mm-travel Horizontal Type SPUJ Series

Lever height of 5.0mm, supporting multi-circuit configurations.

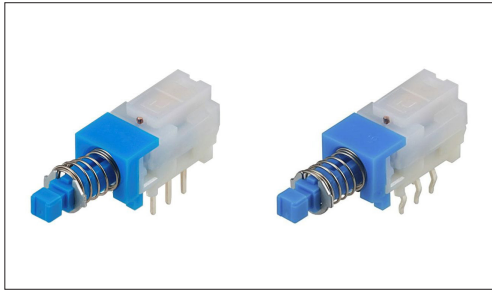

- Rating (max.)/(min.) (Resistive load): 0.1 A 30V DC/50 μ A 3V DC
- Contact resistance (Initial performance/After lifetime):
20m Ω max./40m Ω max.
- Operating life without load: 10,000 cycles 40m Ω max.
- Operating life with load (at max. rated load): 10,000 cycles 40m Ω max.

Applications: Audio_TV:Audio

Product List

Products No.	Travel (mm)	Total travel (mm)	Poles	Operating force	Changeover timing	Mounting method	Operation	Terminal type	Dimensions (W×D×H) (mm)	Automotive	Drawing No.
SPUJ190900	2.0	3.0	2	1.5±1N	Non shorting	PC board	Latching	Straight	15.2×7.5×8.8	—	1
SPUJ191000	2.0	3.0	2	1.5±1N	Non shorting	PC board	Latching	Snap-in	15.2×7.5×8.8	—	2
SPUJ191500	2.0	3.0	2	1.5±1N	Non shorting	PC board	Momentary	Straight	15.2×7.5×8.8	—	1
SPUJ191900	2.0	3.0	2	1.5±1N	Non shorting	PC board	Momentary	Snap-in	15.2×7.5×8.8	—	2
SPUJ193700	2.0	3.0	4	2.3±1N	Non shorting	PC board	Latching	Straight	15.2×7.5×8.8	—	3
SPUJ193900	2.0	3.0	4	2.3±1N	Non shorting	PC board	Latching	Snap-in	15.2×7.5×8.8	—	4
SPUJ194500	2.0	3.0	4	2.3±1N	Non shorting	PC board	Momentary	Straight	15.2×7.5×8.8	—	3

Note

1. This catalog shows only outline specifications. When using the products, please obtain formal specifications for supply.
2. Please place purchase orders per minimum order unit (integer).

Packing Specifications

Bulk

Products No.	Number of packages (pcs.)		Export package measurements (mm)
	1 case / Japan	1 case / export packing	
SPUJ190900 SPUJ191000 SPUJ191500 SPUJ191900	600	3,000	400 x 270 x 290
SPUJ193700 SPUJ193900 SPUJ194500	400	2,000	400 x 270 x 290

2.0mm-travel Horizontal Type
SPUJ Series

Drawing No.1

■ Dimensions

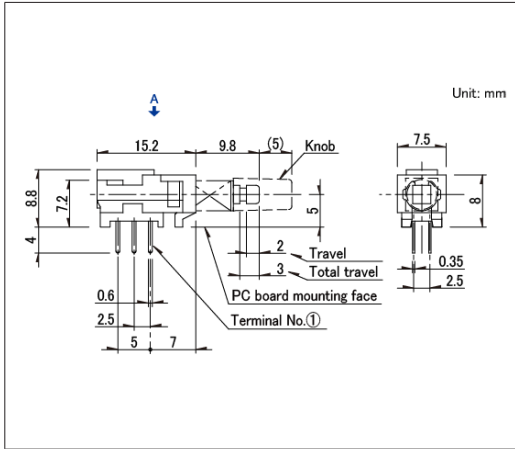

■ Mounting Hole Dimensions

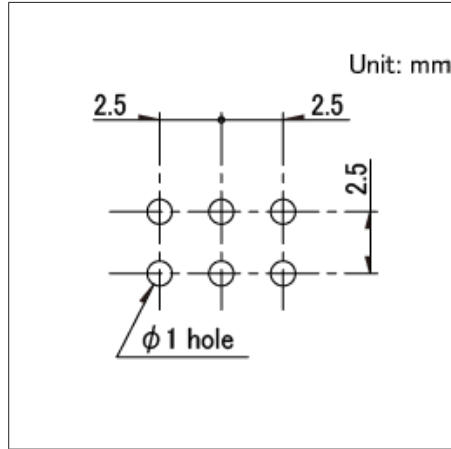

■ Circuit Diagram

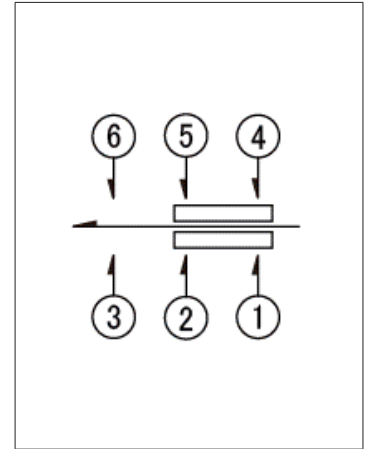

Viewed from direction A in the dimensions.

Drawing No.2

■ Dimensions

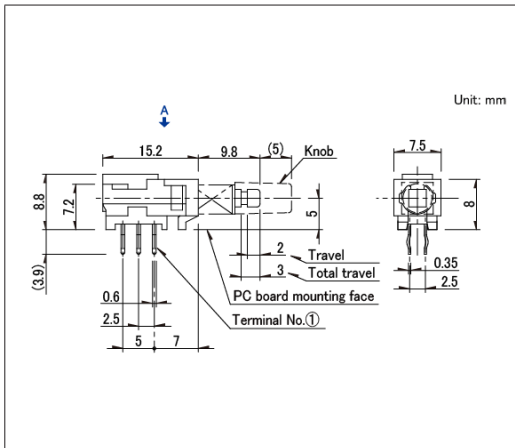

■ Mounting Hole Dimensions

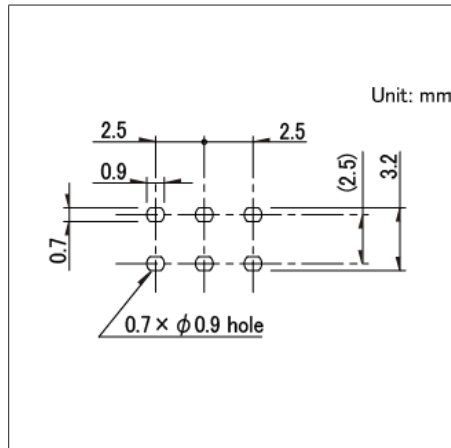

■ Circuit Diagram

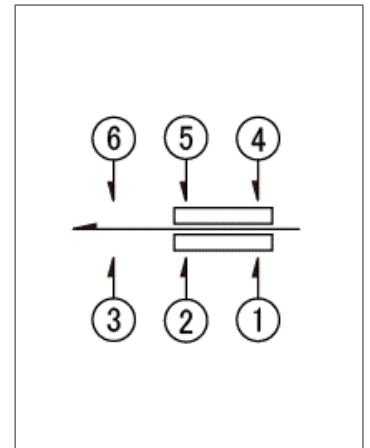

Viewed from direction A in the dimensions.

Drawing No.3

■ Dimensions

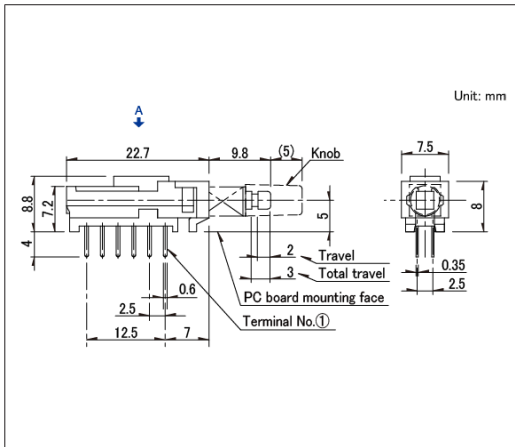

■ Mounting Hole Dimensions

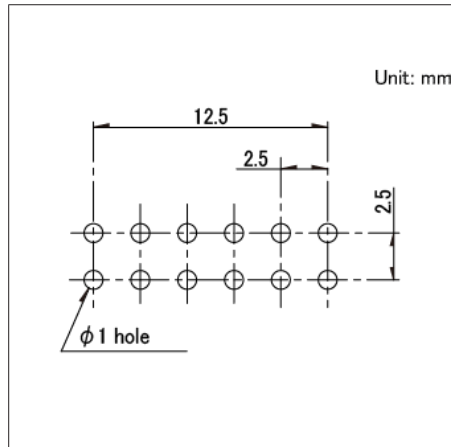

■ Circuit Diagram

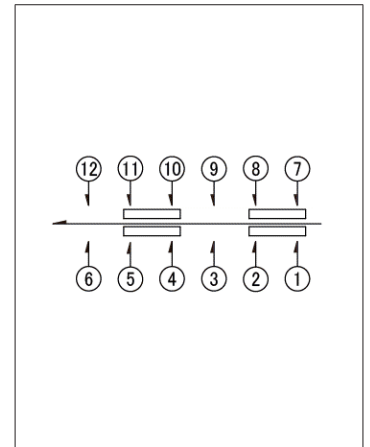

Viewed from direction A in the dimensions.

2.0mm-travel Horizontal Type
SPUJ Series

Drawing No.4

■ Dimensions

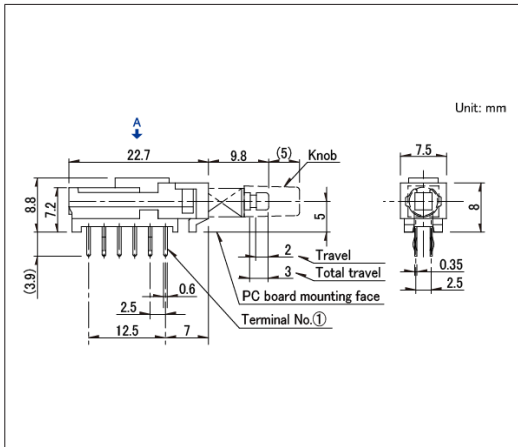

■ Mounting Hole Dimensions

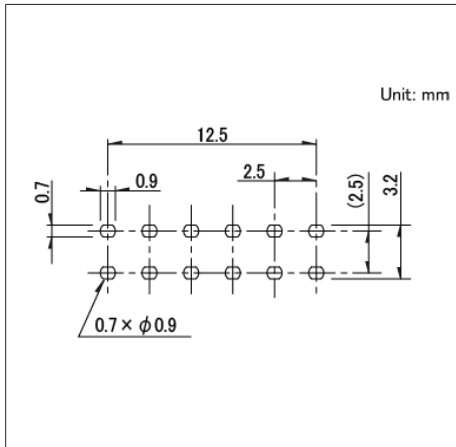

■ Circuit Diagram

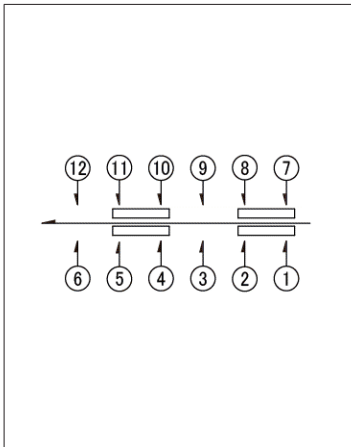

Viewed from direction A in the dimensions.

2.5mm-travel Large-sized Horizontal Type SPUN Series

Includes multi-circuit and medium-current options in the lineup.

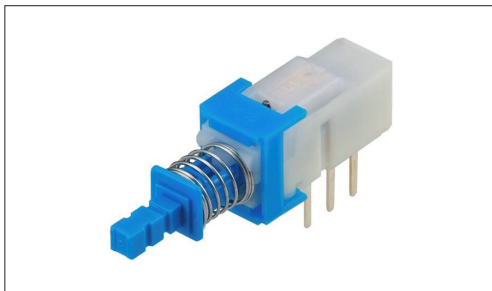

- Rating (max.)/(min.) (Resistive load): 0.1 A 30V DC/50 μ A 3V DC (Standard)
1 A 25V DC/ - (Medium-current)
- Contact resistance (Initial performance/After lifetime):
20m Ω max./40m Ω max.
- Operating life without load: 30,000 cycles 40m Ω max. (Standard)
10,000 cycles 40m Ω max. (Medium-current)
- Operating life with load (at max. rated load):
10,000 cycles 40m Ω max. (Standard)
5,000 cycles 40m Ω max. (Medium-current)

Applications: Audio_TV: Audio

Product List

Products No.	Travel (mm)	Total travel (mm)	Rating	Poles	Operating force	Changeover timing	Mounting method	Operation	Terminal type	Dimensions (W×D×H) (mm)	Automotive	Drawing No.
SPUN191400	2.5	3.5	Standard	2	2 \pm 1N	Non shorting	PC board	Latching	Straight	24.0×10.0×13.0	—	1
SPUN191600	2.5	3.5	Standard	2	2 \pm 1N	Non shorting	PC board	Latching	Snap-in	24.0×10.0×13.0	—	2
SPUN190900	2.5	3.5	Standard	2	2 \pm 1N	Non shorting	PC board	Momentary	Straight	24.0×10.0×13.0	—	1
SPUN191000	2.5	3.5	Standard	2	2 \pm 1N	Non shorting	PC board	Momentary	Snap-in	24.0×10.0×13.0	—	2
SPUN194700	2.5	3.5	Standard	4	2.5 \pm 1N	Non shorting	PC board	Latching	Straight	24.0×10.0×13.0	—	3
SPUN194900	2.5	3.5	Standard	4	2.5 \pm 1N	Non shorting	PC board	Latching	Snap-in	24.0×10.0×13.0	—	4
SPUN192600	2.5	3.5	Medium-current	2	3 \pm 1.5N	Non shorting	PC board	Latching	Straight	24.0×10.0×13.0	—	5
SPUN192800	2.5	3.5	Medium-current	2	3 \pm 1.5N	Non shorting	PC board	Latching	Snap-in	24.0×10.0×13.0	—	2
SPUN19C400	2.5	3.5	Medium-current	4	4 \pm 2N	Non shorting	PC board	Latching	Snap-in	24.0×10.0×13.0	—	4

⚠ Note

1. This catalog shows only outline specifications. When using the products, please obtain formal specifications for supply.
2. Please place purchase orders per minimum order unit (integer).

Packing Specifications

Bulk

Products No.	Number of packages (pcs.)		Export package measurements (mm)
	1 case / Japan	1 case / export packing	
SPUN191400 SPUN191600 SPUN190900 SPUN191000 SPUN192600 SPUN192800	250	1,250	400 x 270 x 290
SPUN194700 SPUN194900 SPUN19C400	140	700	400 x 270 x 290

2.5mm-travel Large-sized Horizontal Type
SPUN Series

Drawing No.1

■ Dimensions

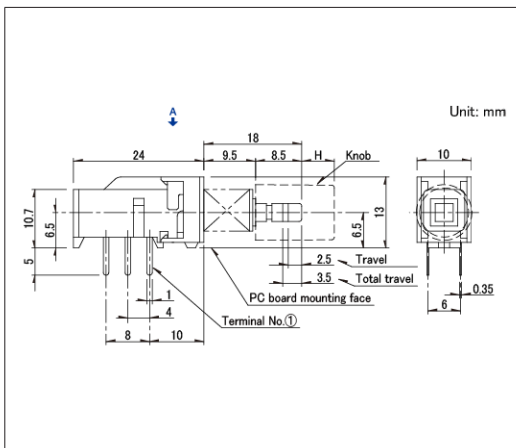

■ Mounting Hole Dimensions

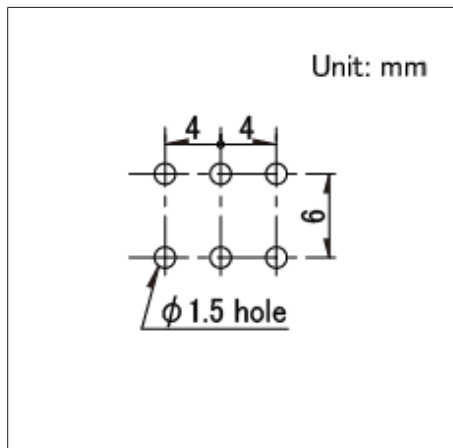

■ Circuit Diagram

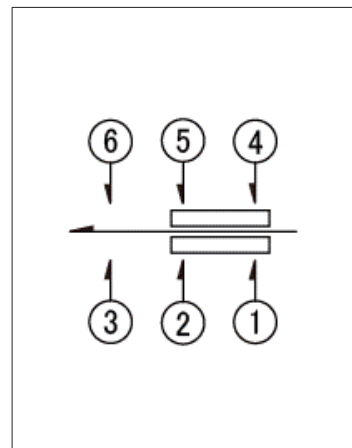

Viewed from direction A in the dimensions.

Drawing No.2

■ Dimensions

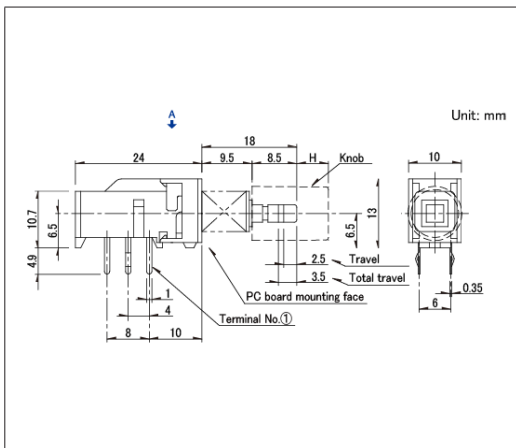

■ Mounting Hole Dimensions

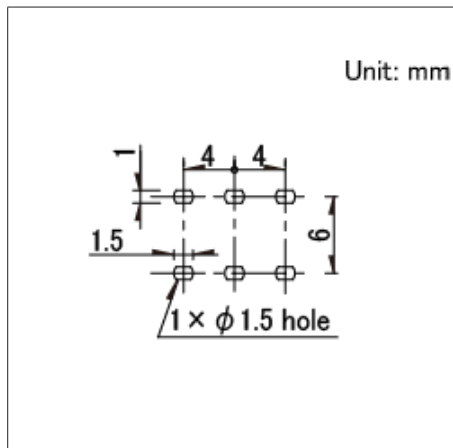

■ Circuit Diagram

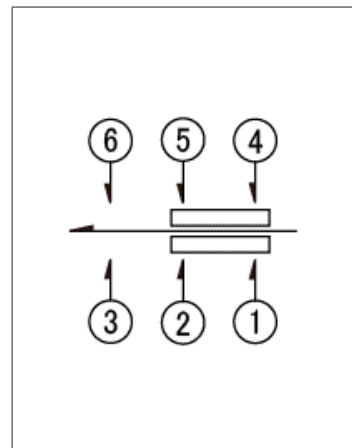

Viewed from direction A in the dimensions.

Drawing No.3

■ Dimensions

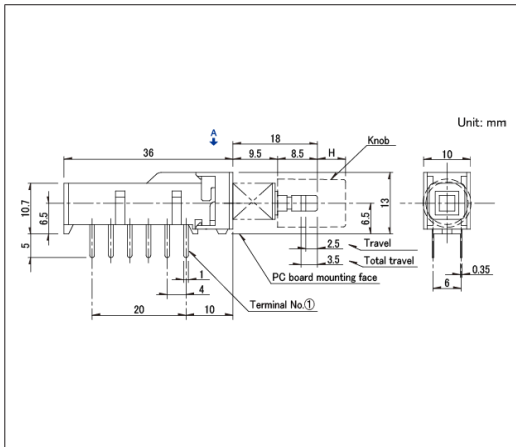

■ Mounting Hole Dimensions

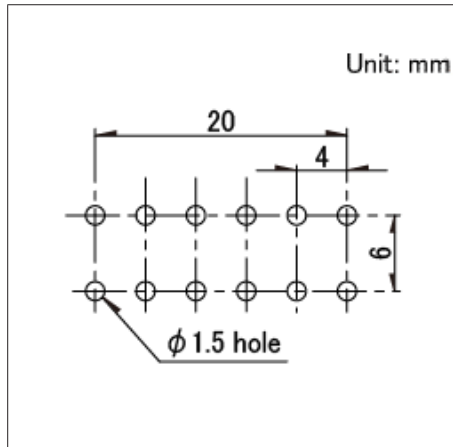

■ Circuit Diagram

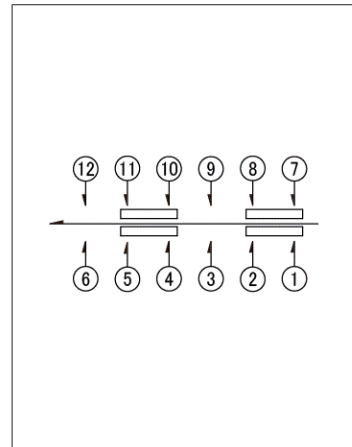

Viewed from direction A in the dimensions.

Switches Push Switches

2.2mm-travel Medium-sized Vertical Type
SPPH4 Series

Medium-sized design prioritizing ease of use.

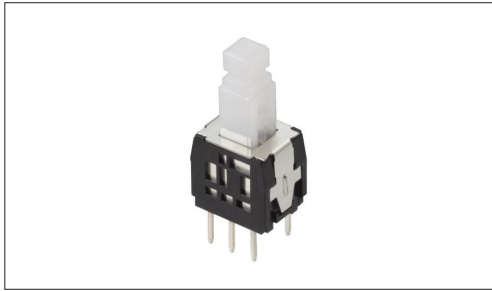

- Rating (max.)/(min.) (Resistive load): 0.1 A 30V DC/50μA 3V DC
- Contact resistance (Initial performance/After lifetime):
100mΩ max. (Initial performance)
- Operating life without load: 10,000 cycles 100mΩ max.
- Operating life with load (at max. rated load): 10,000 cycles 100mΩ max.

Applications: Audio_TV: Visual, Audio, Pro audio

■ Product List

Products No.	Travel (mm)	Total travel (mm)	Poles	Operating force	Changeover timing	Mounting method	Operation	Terminal type	Location lug	Dimensions (W×D×H) (mm)	Automotive	Drawing No.
SPPH410100	2.2	3.0	2	2±1N	Non shorting	PC board	Latching	Straight	With	8.5×6.5×8.5	—	1
SPPH410200	2.2	3.0	2	2±1N	Non shorting	PC board	Momentary	Straight	With	8.5×6.5×8.5	—	
SPPH420100	2.2	3.0	2	2±1N	Non shorting	PC board	Latching	Straight	Without	8.5×6.5×8.5	—	2
SPPH430100	2.2	3.0	2	2±1N	Non shorting	PC board	Latching	Snap-in	With	8.5×6.5×8.5	—	3
SPPH430200	2.2	3.0	2	2±1N	Non shorting	PC board	Momentary	Snap-in	With	8.5×6.5×8.5	—	

⚠ Note

1. This catalog shows only outline specifications. When using the products, please obtain formal specifications for supply.
2. Please place purchase orders per minimum order unit (integer).

■ Packing Specifications

Bulk

Number of packages (pcs.)		Export package measurements (mm)
1 case / Japan	1 case / export packing	
1,200	6,000	400 x 270 x 290

Drawing No. 1

■ Dimensions

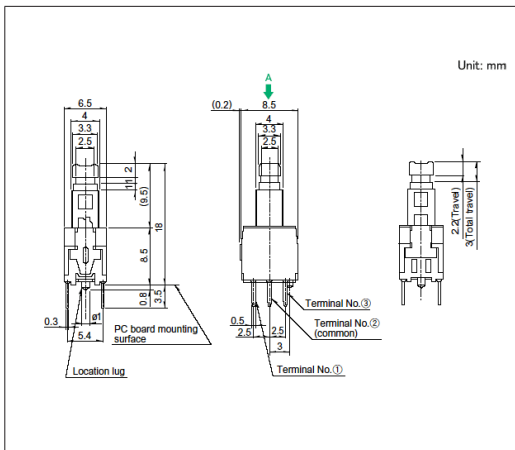

■ Mounting Hole Dimensions

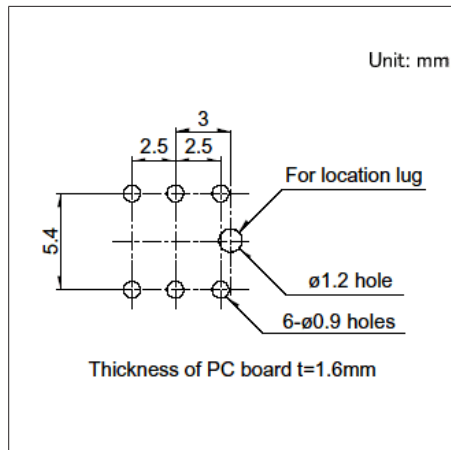

■ Circuit Diagram

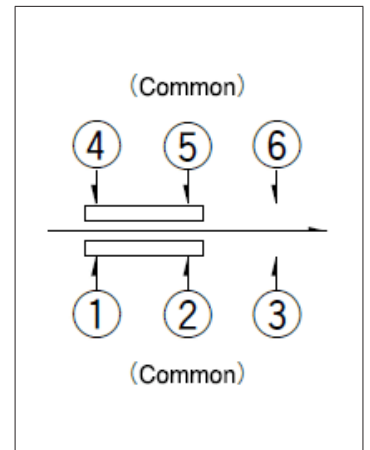

Viewed from direction A in the dimensions.

1.5mm-travel Vertical Type SPPH1 Series

Offers a lineup of two types of knob shapes.

 Automotive

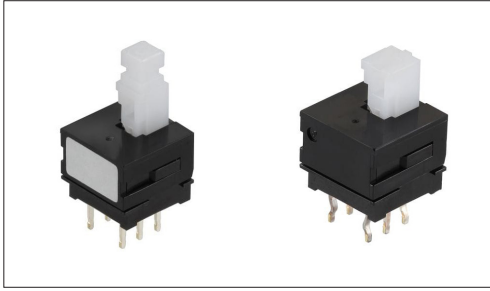

- Rating (max.)/(min.) (Resistive load): 0.1 A 30V DC/50 μ A 3V DC
- Contact resistance (Initial performance/After lifetime):
20m Ω max./40m Ω max.
- Operating life without load: 10,000 cycles 40m Ω max.
- Operating life with load (at max. rated load): 10,000 cycles 40m Ω max.

Applications: Audio_TV: Visual, Audio, Pro audio
Automotive: Navigation/audio systems, HVAC

Product List

Products No.	Travel (mm)	Total travel (mm)	Poles	Operating force	Changeover timing	Mounting method	Operation	Terminal type	Dimensions (W×D×H) (mm)	Automotive	Drawing No.
SPPH110800	1.5	2.5	2	2 (+1, -0.7) N	Non shorting	PC board	Latching	Straight	10.0×10.0×8.5	●	1
SPPH110300	1.5	2.5	2	2 (+1, -0.7) N	Non shorting	PC board	Momentary	Straight	10.0×10.0×8.5	●	2
SPPH120400	1.5	2.5	2	2 (+1, -0.7) N	Non shorting	PC board	Latching	Straight	10.0×10.0×8.5	●	3
SPPH120100	1.5	2.5	2	2 (+1, -0.7) N	Non shorting	PC board	Momentary	Straight	10.0×10.0×8.5	●	4
SPPH130400	1.5	2.5	2	2 (+1, -0.7) N	Non shorting	PC board	Latching	Snap-in	10.0×10.0×8.5	●	5
SPPH130100	1.5	2.5	2	2 (+1, -0.7) N	Non shorting	PC board	Momentary	Snap-in	10.0×10.0×8.5	●	6
SPPH140300	1.5	2.5	2	2 (+1, -0.7) N	Non shorting	PC board	Latching	Snap-in	10.0×10.0×8.5	●	7
SPPH140100	1.5	2.5	2	2 (+1, -0.7) N	Non shorting	PC board	Momentary	Snap-in	10.0×10.0×8.5	●	8
SPPH110900	1.5	2.5	2	3 (+1, -0.7) N	Non shorting	PC board	Latching	Straight	10.0×10.0×8.5	●	9
SPPH130500	1.5	2.5	2	3 (+1, -0.7) N	Non shorting	PC board	Latching	Snap-in	10.0×10.0×8.5	●	10
SPPH140400	1.5	2.5	2	3 (+1, -0.7) N	Non shorting	PC board	Latching	Snap-in	10.0×10.0×8.5	●	11

Note

1. This catalog shows only outline specifications. When using the products, please obtain formal specifications for supply.
2. Please place purchase orders per minimum order unit (integer).
3. This products can be used in vehicles.

Although these products are designed to perform over a wide operating temperature range, please ensure that you receive and read the formal delivery specifications before use.

Packing Specifications

Bulk

Number of packages (pcs.)		Export package measurements (mm)
1 case / Japan	1 case / export packing	
800	4,000	400 x 270 x 290

1.5mm-travel Vertical Type
SPPH1 Series

Drawing No.1

■ Dimensions

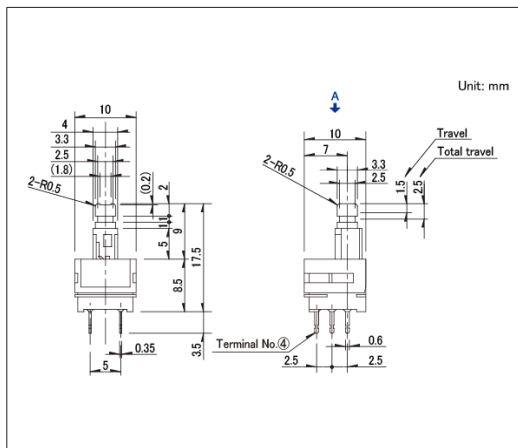

■ Mounting Hole Dimensions

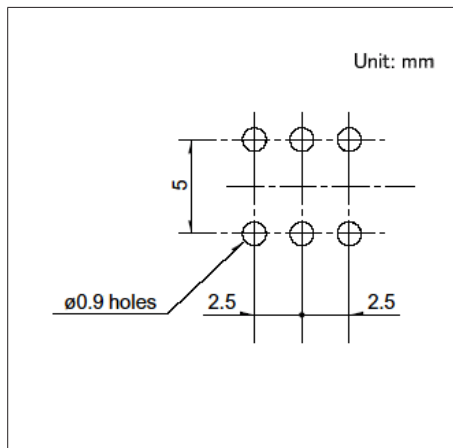

■ Circuit Diagram

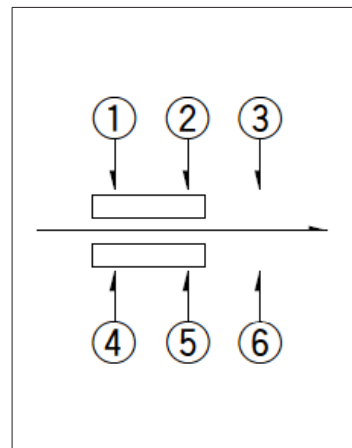

Viewed from direction A in the dimensions.

Drawing No.2

■ Dimensions

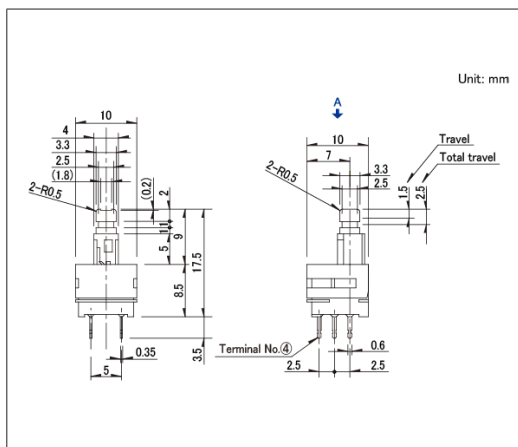

■ Mounting Hole Dimensions

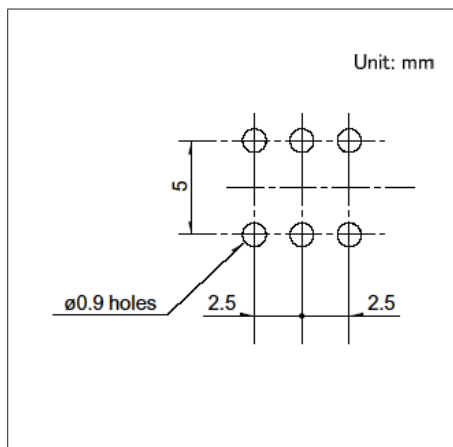

■ Circuit Diagram

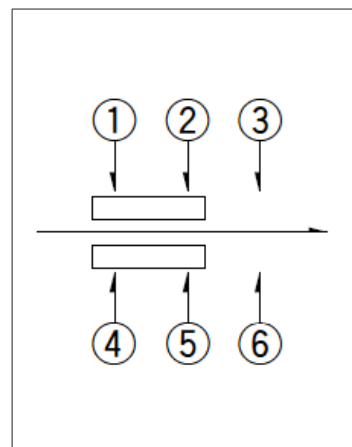

Viewed from direction A in the dimensions.

Drawing No.3

■ Dimensions

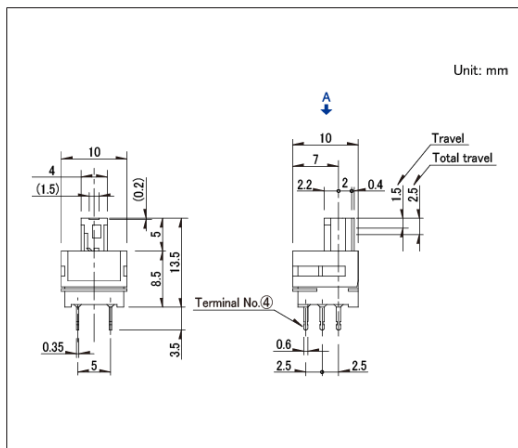

■ Mounting Hole Dimensions

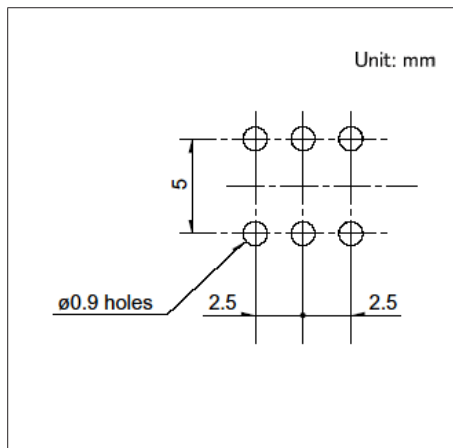

■ Circuit Diagram

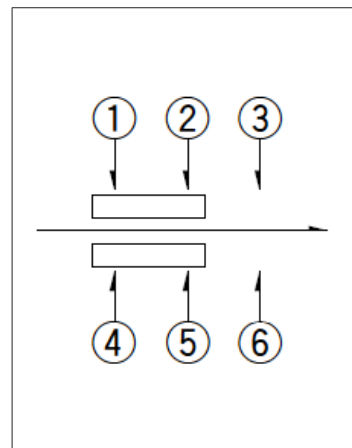

Viewed from direction A in the dimensions.

1.5mm-travel Vertical Type
SPPH1 Series

Drawing No.4

■ Dimensions

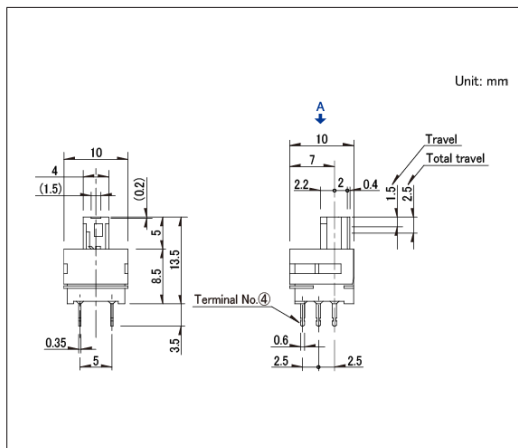

■ Mounting Hole Dimensions

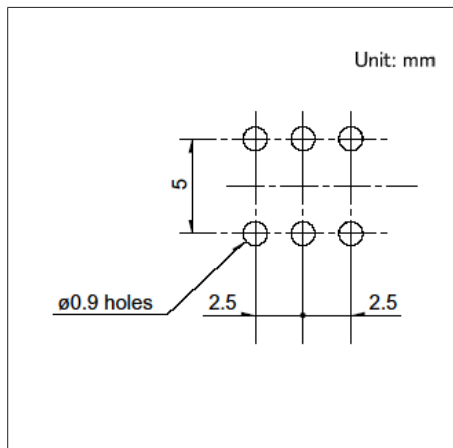

■ Circuit Diagram

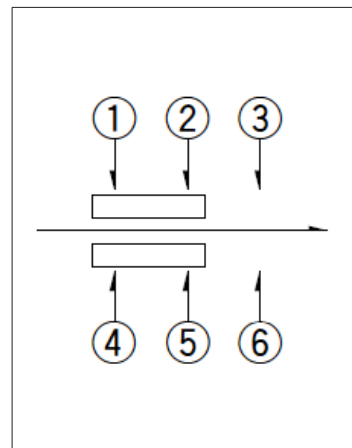

Viewed from direction A in the dimensions.

Drawing No.5

■ Dimensions

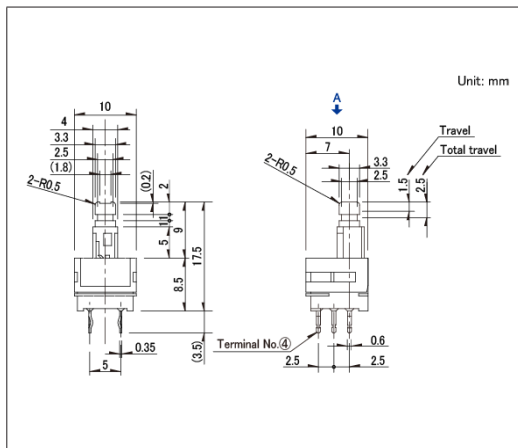

■ Mounting Hole Dimensions

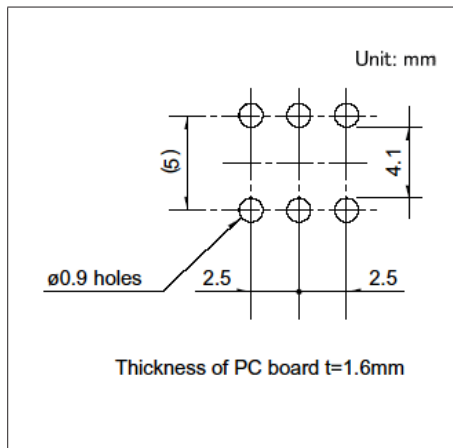

■ Circuit Diagram

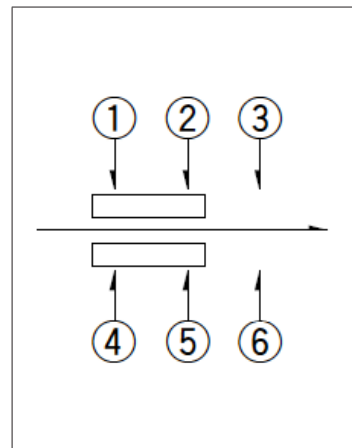

Viewed from direction A in the dimensions.

Drawing No.6

■ Dimensions

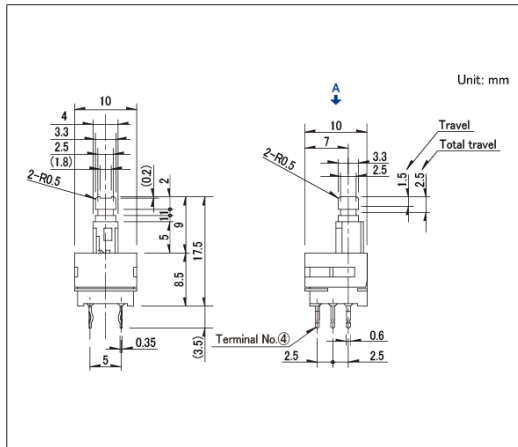

■ Mounting Hole Dimensions

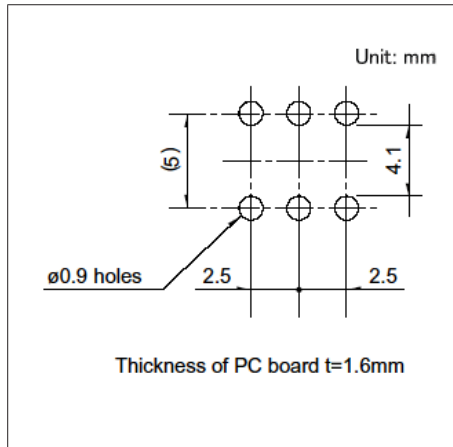

■ Circuit Diagram

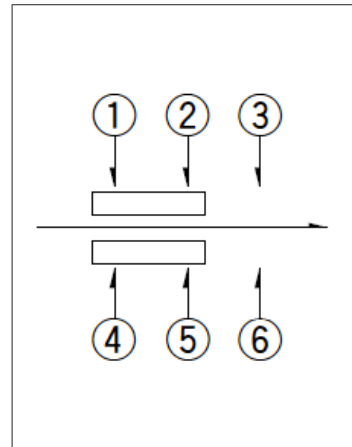

Viewed from direction A in the dimensions.

1.5mm-travel Vertical Type
SPPH1 Series

Drawing No.7

■ Dimensions

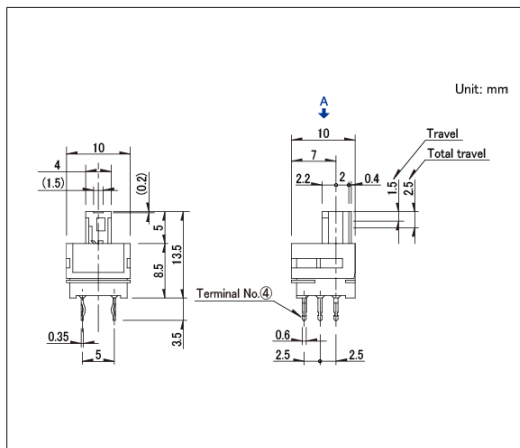

■ Mounting Hole Dimensions

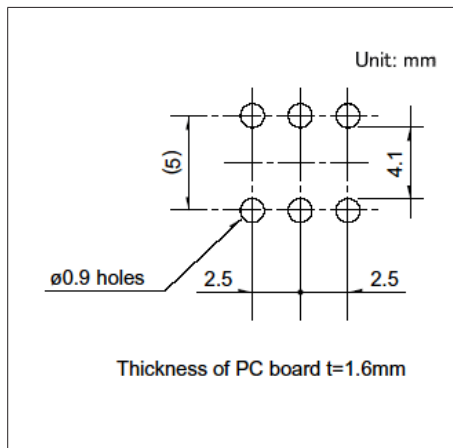

■ Circuit Diagram

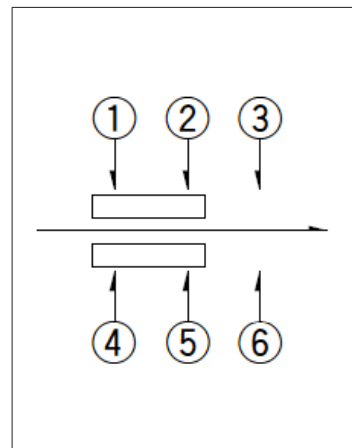

Viewed from direction A in the dimensions.

Drawing No.8

■ Dimensions

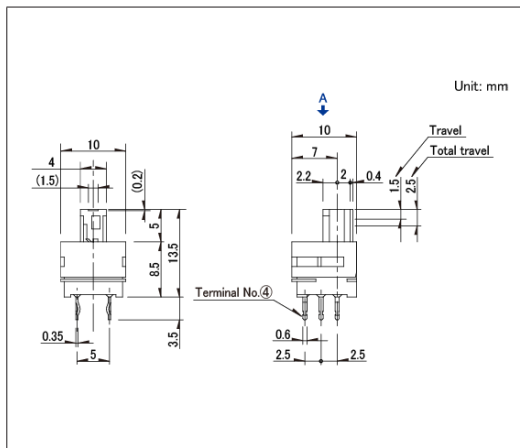

■ Mounting Hole Dimensions

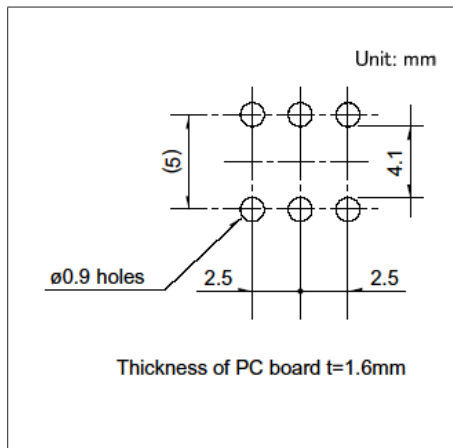

■ Circuit Diagram

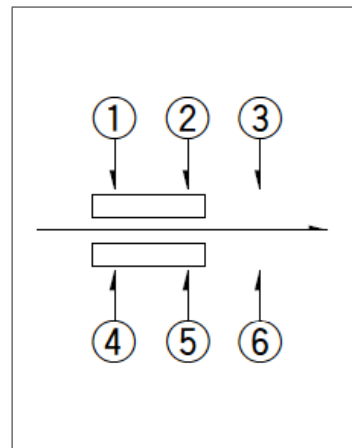

Viewed from direction A in the dimensions.

Drawing No.9

■ Dimensions

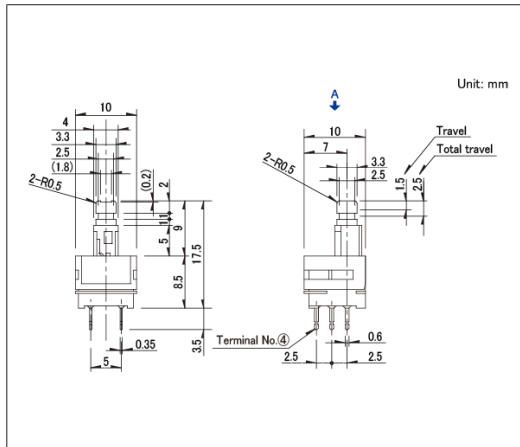

■ Mounting Hole Dimensions

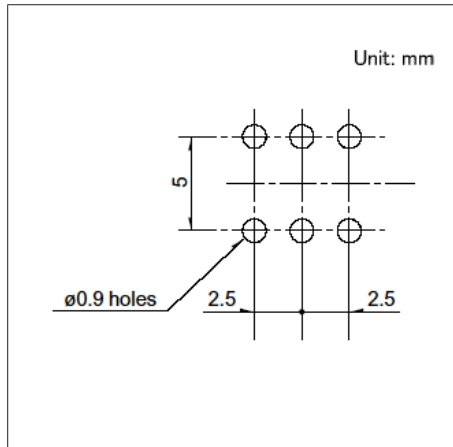

■ Circuit Diagram

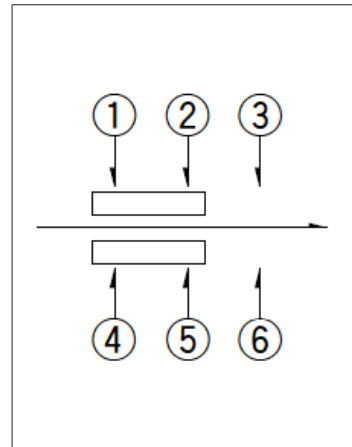

Viewed from direction A in the dimensions.

1.5mm-travel Vertical Type
SPPH1 Series

Drawing No.10

■ Dimensions

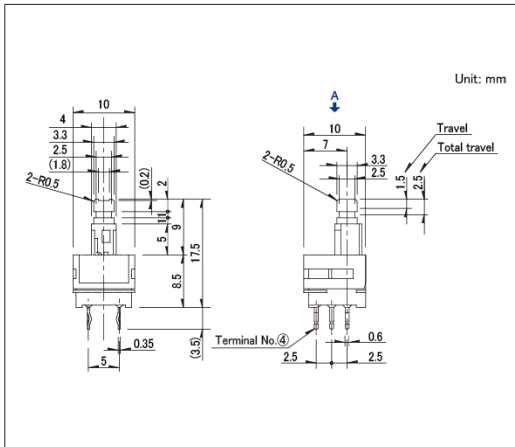

■ Mounting Hole Dimensions

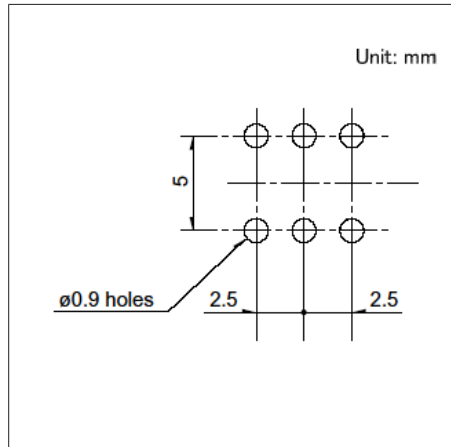

■ Circuit Diagram

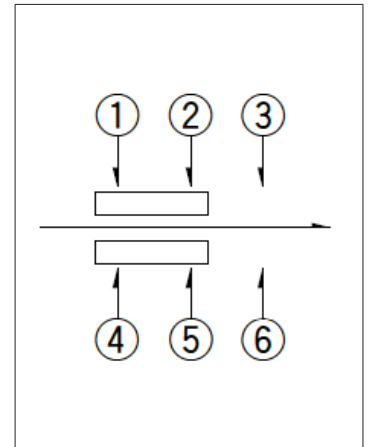

Viewed from direction A in the dimensions.

Drawing No.11

■ Dimensions

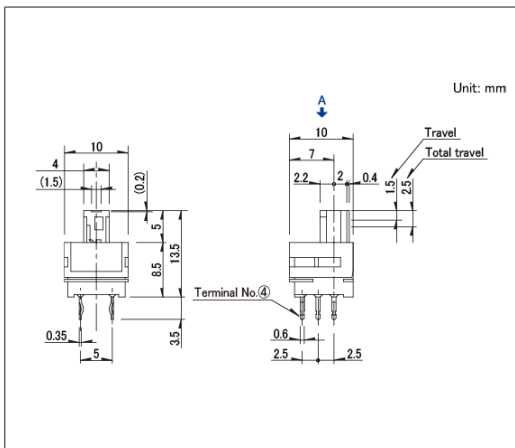

■ Mounting Hole Dimensions

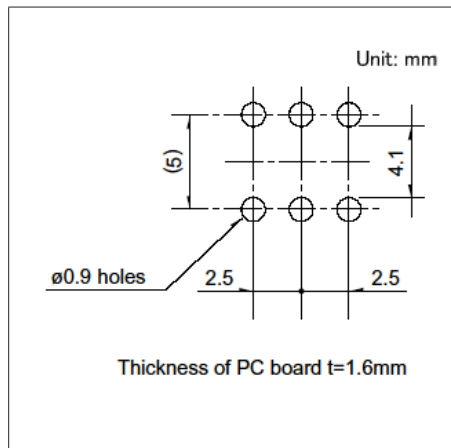

■ Circuit Diagram

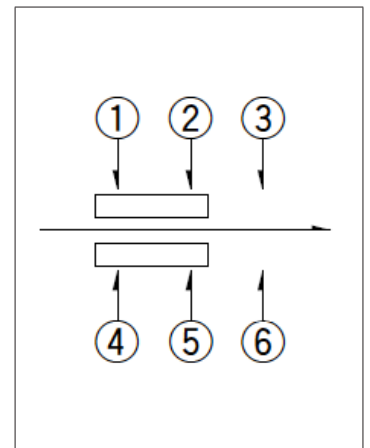

Viewed from direction A in the dimensions.

Switches

Push Switches

1.5mm-travel Vertical Type
SPEF Series

Supports surface mounting with lead-free solder.

 Automotive

- Rating (max.)/(min.) (Resistive load): 1A 14.5V DC/50 μ A 3V DC
- Contact resistance (Initial performance/After lifetime): 100m Ω max./1 Ω max.
- Operating life with load (at max. rated load): 30,000 cycles 100m Ω max.

Applications: Automotive: Map Lamp, Hazard Lights

■ Product List

Products No.	Travel (mm)	Total travel (mm)	Poles	Positions	Operating force	Changeover timing	Mounting method	Operation	Terminal type	Dimensions (W×D×H) (mm)	Automotive	Drawing No.
SPEF210101	1.5	2.7	1	2	3N	Non shorting	PC board	Latching	Reflow	9.4×9.0×6.9	●	1
SPEF110100	1.5	2.7	1	2	3N	Non shorting	PC board	Latching	Dip	9.4×9.0×6.9	●	2
SPEF210200	1.5	2.7	1	2	5N	Non shorting	PC board	Latching	Reflow	9.4×9.0×6.9	●	1
SPEF110200	1.5	2.7	1	2	5N	Non shorting	PC board	Latching	Dip	9.4×9.0×6.9	●	2
SPEF220100	—	2.7	1	2	3N	Non shorting	PC board	Alternate	Reflow	9.4×9.0×6.9	●	3
SPEF120100	—	2.7	1	2	3N	Non shorting	PC board	Alternate	Dip	9.4×9.0×6.9	●	4
SPEF220200	—	2.7	1	2	5N	Non shorting	PC board	Alternate	Reflow	9.4×9.0×6.9	●	3
SPEF120200	—	2.7	1	2	5N	Non shorting	PC board	Alternate	Dip	9.4×9.0×6.9	●	4

 Note

1. This catalog shows only outline specifications. When using the products, please obtain formal specifications for supply.
2. Please place purchase orders per minimum order unit (integer).
3. This products can be used in vehicles.

Although these products are designed to perform over a wide operating temperature range, please ensure that you receive and read the formal delivery specifications before use.

■ Packing Specifications

Taping

Products No.	Number of packages(pcs.)			Tape width (mm)	Export package measurements (mm)
	1 reel	1 case / Japan	1 case / export packing		
SPEF210101 SPEF210200 SPEF220100 SPEF220200	165	660	1,320	32	403×403×360

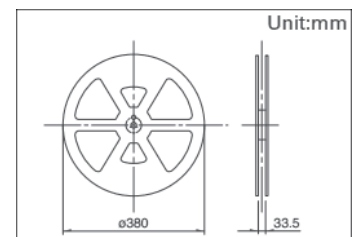

Tray

Products No.	Number of packages(pcs.)		Export package measurements (mm)
	1 case / Japan	1 case / export packing	
SPEF110100 SPEF110200 SPEF120100 SPEF120200	1,050	4,200	540 x 360 x 230

Switches Push Switches

4.5mm-travel Push-push Type
SPED2 Series

Provides smooth and linear operation feel.

Automotive

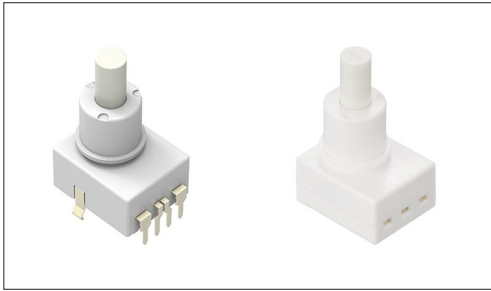

- Rating (max.)/(min.) (Resistive load): 1A 14.5V DC / -
- Contact resistance (Initial performance/After lifetime):
100mΩ max./100mΩ max.
- Operating life with load (at max. rated load): 30,000 cycles 100mΩ max.

Applications: Automotive: Map Lamp

■ Product List

Products No.	Total travel (mm)	Poles	Positions	Operating force	Changeover timing	Mounting method	Operation	Terminal type	Dimensions (W×D×H) (mm)	Automotive	Drawing No.
SPED220200	4.5	2	1	4.17±0.74N	Non shorting	PC board	Alternate	For PC board	16.8×14.0×9.5	●	1
SPED210203	4.5	1	2	4.17±0.74N	Non shorting	Connector	Alternate	—	16.8×14.0×9.5	●	2

Note

1. This catalog shows only outline specifications. When using the products, please obtain formal specifications for supply.
2. Please place purchase orders per minimum order unit (integer).
3. This products can be used in vehicles.
Although these products are designed to perform over a wide operating temperature range, please ensure that you receive and read the formal delivery specifications before use.

■ Packing Specifications

Tray

Products No.	Number of packages(pcs.)		Export package measurements (mm)
	1 case / Japan	1 case / export packing	
SPED220200	280	1,120	555 x 375 x 223

Bulk

Products No.	Number of packages(pcs.)		Export package measurements (mm)
	1 case / Japan	1 case / export packing	
SPED210203	400	2,000	400 x 270 x 290

Drawing No. 1

■ Dimensions

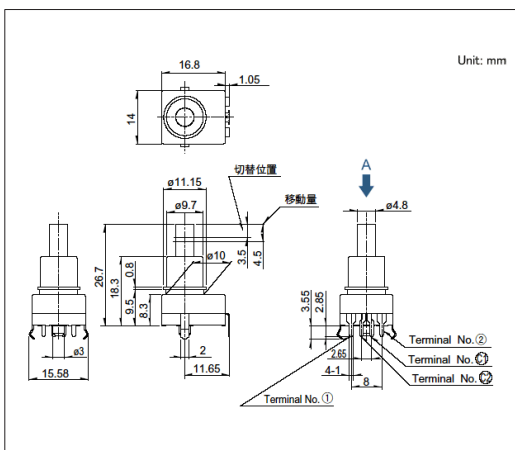

■ Mounting Hole Dimensions

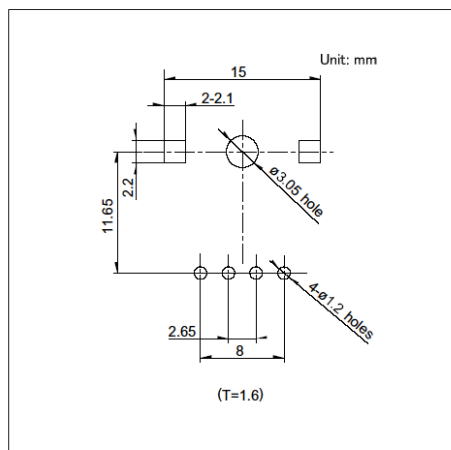

Viewed from direction A in the dimensions.

■ Circuit Diagram

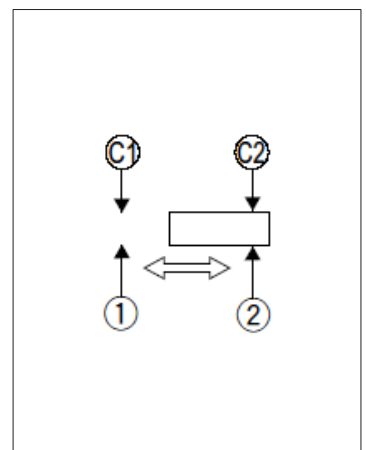

Factory setting for contact points can be either 1 or 2.

4.5mm-travel Push-push Type
SPED2 Series

Drawing No.2

■ Dimensions

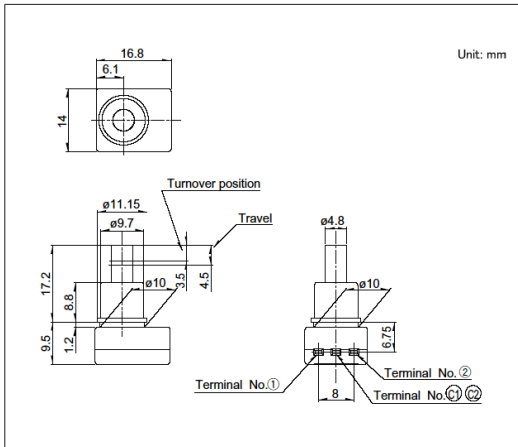

■ Circuit Diagram

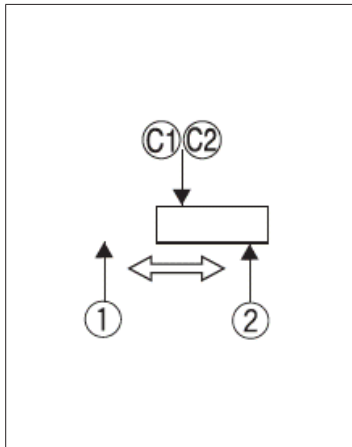

Factory setting for contact points can be either 1 or 2.

Switches Push Switches

3.8mm-travel Push-push Type SPED3 Series

Provides smooth and linear operation feel.

 Automotive

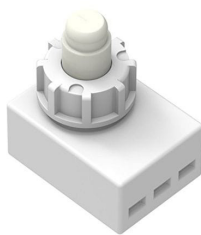

- Rating (max.)/(min.) (Resistive load): 2A 14.5V DC/ -
- Contact resistance (Initial performance/After lifetime):
100mΩ max./100mΩ max.
- Operating life with load (at max. rated load): 30,000 cycles 100mΩ max.

Applications: Automotive: Map Lamp

■ Product List

Products No.	Total travel (mm)	Poles	Positions	Operating force	Changeover timing	Mounting method	Operation	Dimensions (W×D×H) (mm)	Automotive	Drawing No.
SPED310200	3.8	1	2	4.17±0.74N	Non shorting	Connector	Alternate	18.0×14.0×7.4		1

 Note

1. This catalog shows only outline specifications. When using the products, please obtain formal specifications for supply.
2. Please place purchase orders per minimum order unit (integer).
3. This products can be used in vehicles.
Although these products are designed to perform over a wide operating temperature range, please ensure that you receive and read the formal delivery specifications before use.

■ Packing Specifications

Bulk

Number of packages (pcs.)		Export package measurements (mm)
1 case / Japan	1 case / export packing	
500	2,500	400 x 270 x 290

Drawing No.1

■ Dimensions

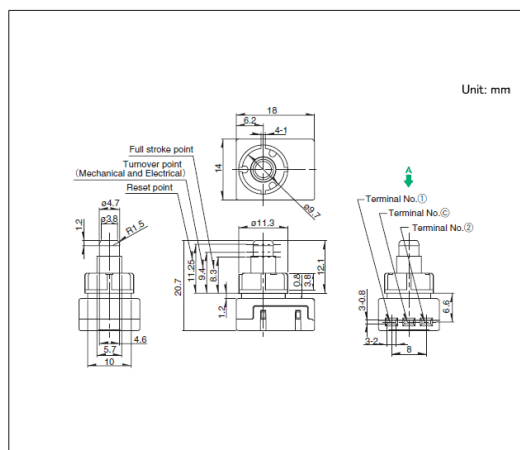

■ Circuit Diagram

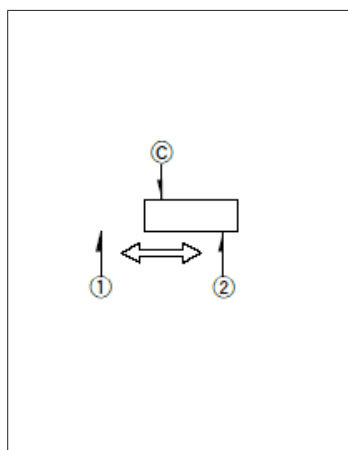

Factory setting for contact points can be either 1 or 2.

Switches Push Switches

3.8mm-travel Push-push Type
SPED4 Series

Provides smooth and linear operation feel.

Automotive

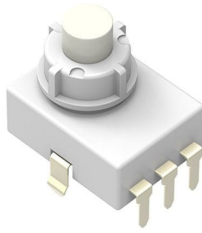

- Rating (max.)/(min.) (Resistive load): 2A 14.5V DC/ -
- Contact resistance (Initial performance/After lifetime):
100mΩ max./100mΩ max.
- Operating life with load (at max. rated load): 30,000 cycles 100mΩ max.

Applications: Automotive: Map Lamp

■ Product List

Products No.	Total travel (mm)	Poles	Positions	Operating force	Changeover timing	Mounting method	Operation	Terminal type	Dimensions (W×D×H) (mm)	Automotive	Drawing No.
SPED420200	3.8	1	2	4.17±0.74N	Non shorting	PC board	Alternate	For PC board	18.0×14.0×7.27		1

Note

1. This catalog shows only outline specifications. When using the products, please obtain formal specifications for supply.
2. Please place purchase orders per minimum order unit (integer).
3. This products can be used in vehicles.
Although these products are designed to perform over a wide operating temperature range, please ensure that you receive and read the formal delivery specifications before use.

■ Packing Specifications

Tray

Number of packages (pcs.)		Export package measurements (mm)
1 case / Japan	1 case / export packing	
280	1,120	555 x 375 x 223

Drawing No.1

■ Dimensions

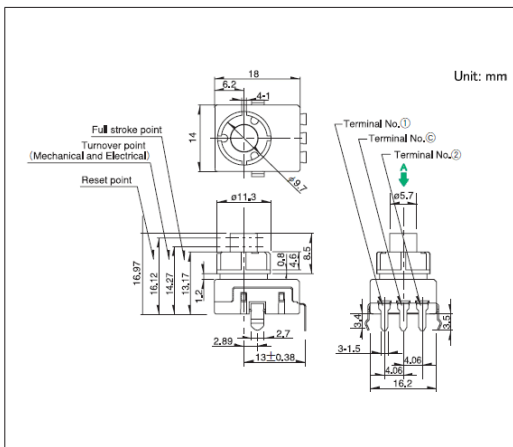

■ Mounting Hole Dimensions

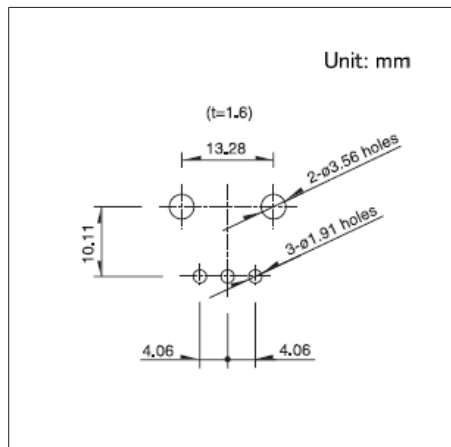

Viewed from direction A in the dimensions.

■ Circuit Diagram

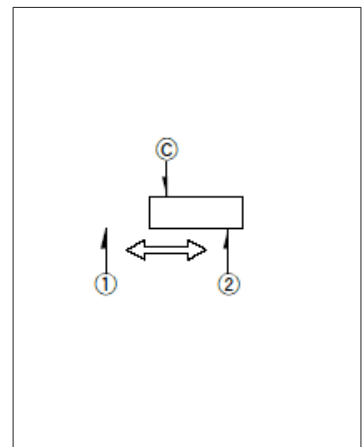

Factory setting for contact points can be either 1 or 2.

Push Switches / Soldering Conditions

■ Example of Reflow Soldering Condition

1. Heating method: Double heating method with infrared heater.
2. Temperature measurement: Thermocouple ϕ 0.1 to 0.2 CA (K) or CC (T) at soldering portion (copper foil surface).
A heat resisting tape should be used for fixed measurement.
3. Temperature profile

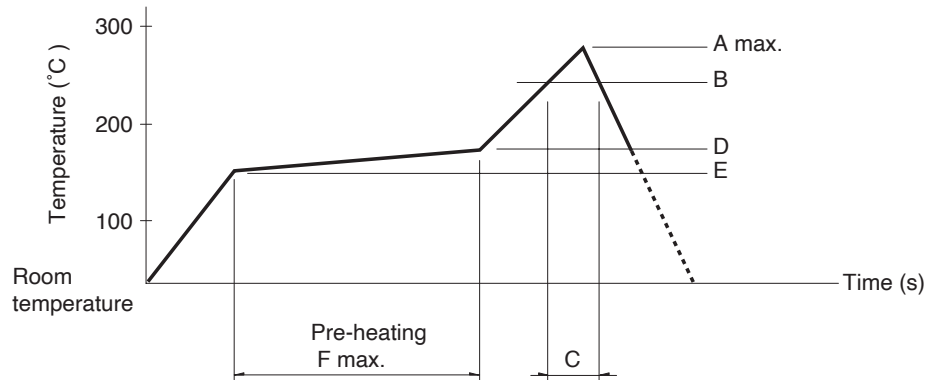

Series (Reflow type)	A (°C) 3s max.	B (°C)	C (s)	D (°C)	E (°C)	F (s)
SPEJ	260	230	40	180	150	120
SPEF						

⚠ Note

1. The condition mentioned above is the temperature on the mounting surface of a PC board. There are cases where the PC board's temperature greatly differs from that of the switch, depending on the PC board's material, size, thickness, etc.
The above-stated conditions shall also apply to switch surface temperatures.
2. Soldering conditions differ depending on reflow soldering machines. Prior verification of soldering condition is highly recommended.

■ Reference for Hand Soldering

Series	Soldering temperature	Soldering time
SPPJ3, SPPJ2, SPUN, SPUJ, SPPH4, SPPH1	350±10°C	3+1/0s
SPED2, SPED4	350±10°C	3±0.5s
SPEJ	350±10°C	4s max.
SPEF	350±5°C	3s max.

■ Reference for Dip Soldering

(For PC board terminal types)

Series	Items		Dip soldering	
	Preheating temperature	Preheating time	Soldering temperature	Duration of immersion
SPPJ3	100°C max.	60s max.	260±5°C	5±1s
SPUN	100°C max.	60s max.	260±5°C	10±1s
SPUJ, SPPH4	—		260±5°C	5±1s
SPPJ2, SPPH1, SPED2, SPED4, SPEF	—		260±5°C	10±1s

Push Switches / Cautions

1. Applying load to terminals during soldering under certain conditions may cause deformation and electrical property degradation.
2. Avoid use of water-soluble soldering flux, since it may corrode the switches.
3. Check and conform to soldering requirements under actual mass production conditions.
4. When soldering twice, wait until the first soldered portion cools to normal temperature. Continuous heating will deform the external portions, loosen or dislodge terminals, or may deteriorate their electrical characteristics.
5. Flux from around and above the PC board should not adhere to the switches.
6. After mounting the switches, if you intend to put the board into an oven in order to harden adhesive for other parts, please consult with us.
7. Before soldering switches with locking mechanism, release the locks. If they are soldered without releasing the locks, the soldering heat may deform the locking mechanism.
8. If you use a through-hole PC board or a PC board thinner or thicker than the recommendation, there may be greater heat stress. Verify the soldering conditions thoroughly before use.
9. Solder the switches with detent at the detent position. Soldering switches fixed at the center of the detent may deform the detent mechanisms.
10. No cleaning.
11. Protect small and thin switches from external forces in the set mounting process.
12. Tighten the mounting screws by applying the specified torque. Tightening with larger torque than the specified one will result in malfunction or breakage of screws.
13. The products are designed and manufactured for direct current resistance. Contact us for use of other resistances such as inductive (L) or capacitive (C).
14. The switch will break if you apply a greater stress than that specified. Take great care not to let the switch be subject to greater stress than specified.
15. Be sure to release the locks before removing the knobs. Otherwise, the locking mechanism may be deformed.
16. Be sure to use the forced travel close to the position of the whole travel as much as possible.
17. Insert these switches to the specified mounting surface and mount them horizontally. If not mounted horizontally, these switches will malfunction.
18. Use of the switches in a dusty environment may lead to dusts entering through the openings and cause imperfect contact or malfunction. Take this into account for set design.
19. Corrosive gas if generated by peripheral parts of a set, malfunction such as imperfect contact may occur. Thorough investigation shall be required beforehand.
20. Storage
Store the products as delivered at normal temperature and humidity, out of direct sunlight and away from corrosive gases. Use them as soon as possible and no later than six months after delivery.
Once the seal is broken, use them as soon as possible.