







# Switches

● Detector Switches	2
● Slide Switches	112
● Push Switches	164
● Rotary Switches	193

## Switches

## Detector Switches







## List of Varieties

Series	SPVS	SPVN	SPVT	SPVM	SPVR	SPVE	SSCQ	
Photo								
Features/Type	Horizontal Compact	Horizontal Low-profile	Horizontal	Vertical Compact	Vertical Low-profile lever type	Vertical Compact push operation type	Horizontal Compact	
Operation type	Two-way operation type					One-way operation type	Two-way output, two-step detection type	
Water-proof	—	—	—	—	—	—	—	
Dust-proof	—	—	—	—	—	—	—	
IP standard	—	—	—	—	—	—	—	
Dimensions (mm)	3.3×3.5×1.0	3.6×3.8×1.0	4.7×5.6×1.9	2.8×3.5×1.5	3.6×4.2×1.2	3.4×3.0×2.3 3.4×4.0×1.8	3.8×3.6×0.9	
Poles	1							
Positions	1						Two-direction, 2-positions each side	
Operating force	0.35N max.		0.4N max.		0.35N max.	0.3N max.	0.35N max.	
Operating temperature range	-40°C to +85°C					-10°C to +60°C		
Rating(max.)/(min.) (Resistive load)	1mA 5V DC/50μA 3V DC		50mA 20V DC/ 100μA 3V DC	1mA 5V DC/ 50μA 3V DC	1mA 5V DC/ 100μA 3V DC	0.1A 30V DC/ 50μA 3V DC	1mA 5V DC/ 50μA 3V DC	
Electrical performance	Contact resistance (Initial/After operating life)	2Ω max./5Ω max.		500mΩ max./ 1Ω max.	2Ω max./ 5Ω max.	3Ω max./ 5Ω max.	500mΩ max./ 1Ω max.	2Ω max./ 5Ω max.
	Insulation resistance	100MΩ min. 100V DC						
	Voltage proof	100V AC for 1 minute						
Mechanical performance	Terminal strength	0.5N for 1 minute		1N for 1 minute	0.5N for 1 minute			
	Actuator strength	5N	10N	5N	2N	5N	1N	
Durability	Operating life without load	50,000 cycles 5Ω max.		100,000 cycles 1Ω max.	50,000 cycles 5Ω max.		50,000 cycles 1Ω max.	50,000 cycles 5Ω max.
	Operating life with load Rating(max.) (Resistive load)	50,000 cycles 5Ω max.		100,000 cycles 1Ω max.	50,000 cycles 5Ω max.		50,000 cycles 1Ω max.	50,000 cycles 5Ω max.
Environmental performance	Cold	-40°C 96h				-20°C 96h		
	Dry heat	85°C 96h						
	Damp heat	40°C, 90 to 95%RH 96h						
Automotive	●	●	●	●	●	—	—	

 Note

● Indicates applicability to all products in the series, while ○ indicates applicability to some products in the series.







# Detector Switches

Series	SSCM	SPVL	SPPB	SSCT	SSCF	SSCW	SSCL	
Photo								
Features/Type	Horizontal Compact	Horizontal Low-profile	General-purpose type	Micro switch type	Two-way output type	With female connector terminal		
Operation type	Two-way output type	Multi-direction operation type	One-way output type Two-way output type	Two-way output type				
Water-proof	—	—	—	—	—	—	—	
Dust-proof	—	—	—	—	—	—	—	
IP standard	—	—	—	—	—	—	—	
Dimensions (mm)	4.0×5.0×1.5	6.6×5.55×1.0	6.3×3.0×4.9 6.3×5.1×3.7 6.3×6.1×4.25 6.4×3.0×4.9 6.5×3.1×4.9 8.8×3.5×5.1 9.15×3.75×5.5 9.7×3.75×5.1 9.75×3.75×5.7 10.0×6.1×5.25	12.5×5.0×11.5	11.0×5.8×12.4 15.5×5.8×12.4	5.3×13.1×11.35	5.3×11.0×16.1	
Poles	1							
Positions	2	1		2		1	2	
Operating force	0.35N max.			0.7±0.3N	0.7N max.	1N max.	0.7N max.	
Operating temperature range	-10°C to +60°C		-40°C to +85°C					
Rating(max.)/(min.) (Resistive load)	1mA 5V DC/50μA 3V DC		0.1A 30V DC/ 50μA 3V DC	0.1A 12V DC/50μA 3V DC		0.1A 12V DC/ 100μA 3V DC	0.1A 12V DC/ 50μA 5V DC	
Electrical performance	Contact resistance (Initial/After operating life)	2Ω max./5Ω max.		1Ω max./ 2Ω max.	200mΩ max./ 500mΩ max.	100mΩ max./ 300mΩ max.	500mΩ max./1Ω max.	
	Insulation resistance	100MΩ min. 100V DC			100MΩ min. 250V DC	100MΩ min. 100V DC	100MΩ min. 250V DC	100MΩ min. 100V DC
	Voltage proof	100V AC for 1 minute			250V AC for 1 minute	100V AC for 1 minute	250V AC for 1 minute	100V AC for 1 minute
Mechanical performance	Terminal strength	0.5N for 1 minute	1N for 1 minute	3N for 1 minute		5N for 1 minute	—	
	Actuator strength	2N	5N	10N	20N	10N	20N	10N
Durability	Operating life without load	50,000 cycles 5Ω max.		50,000 cycles 2Ω max.	10,000 cycles 500mΩ max.	50,000 cycles 300mΩ max.	100,000 cycles 1Ω max.	50,000 cycles 1Ω max.
	Operating life with load Rating(max.) (Resistive load)	50,000 cycles 5Ω max.		50,000 cycles 2Ω max.	10,000 cycles 500mΩ max.	50,000 cycles 300mΩ max.	100,000 cycles 1Ω max.	50,000 cycles 1Ω max.
Environmental performance	Cold	-20°C 96h	-40°C 500h					
	Dry heat	85°C 96h	85°C 500h					
	Damp heat	40°C, 90 to 95%RH 96h	60°C, 90 to 95%RH 500h					
Automotive	—	●	●	●	●	●	●	

### ⚠ Note

● Indicates applicability to all products in the series, while ○ indicates applicability to some products in the series.





# Detector Switches

Series		SSCZ	SPVQ3	SPVQ6	SPVQ7	SPVQ8	SPVQ8H	SPVQ9
Photo								
Features/Type		Connector terminal 1-pole 2-positions type	Water-proof type Long travel type	Compact size & water-proof type With internal resistor type	Water-proof type	Ultra-compact & water-proof type With internal resistor type	Water-proof type	Water-proof type Two-pole fast switching type
Operation type		Two-way output type		One-way output type Two-way output type	Two-way output type			
Water-proof		—	●	●	●	●	●	●
Dust-proof		—	●	●	●	●	●	●
IP standard		—	IP6K7	IP6K7	IP6K7	IP6K7	IP6K7	IP6K7
Dimensions (mm)		13.84×5.4×15.4	5.3×13.0×8.35	5.3×13.3×6.5	5.4×14.7×6.7	5.3×8.3×6.5	6.45×14.8×14.5 6.45×17.95×14.5	8.4×15.4×7.5
Poles		1						2
Positions		2	1 2			1		2
Operating force		1.1N max.	1±0.5N 3N max.		1±0.5N	1±0.5N 3N max.	4.7N max.	1±0.5N
Operating temperature range		-40°C to +85°C						
Rating(max.)/(min.) (Resistive load)		0.1A 16V DC/ 100μA 3V DC	0.1A 12V DC/ 50μA 5V DC	0.1A 12V DC/ 50μA 5V DC Respond individually	0.1A 12V DC/ 50μA 5V DC	0.1A 16V DC/ 50μA 5V DC Respond individually	0.1A 16V DC/ 50μA 5V DC	50mA 26V DC/ 50μA 5V DC
Electrical performance	Contact resistance (Initial/After operating life)	500mΩ max./1Ω max.		500mΩ max./1Ω max. Respond individually	500mΩ max./ 1Ω max.	500mΩ max./1Ω max. 500mΩ max./3Ω max. Respond individually	500mΩ max./ 1Ω max.	75mΩ max./ 200mΩ max.
	Insulation resistance	100MΩ min. 250V DC	100MΩ min. 500V DC	100MΩ min. 500V DC Respond individually	100MΩ min. 500V DC	100MΩ min. 500V DC Respond individually	100MΩ min. 500V DC	
	Voltage proof	250V AC for 1minute	500V AC for 1 minute	500V AC for 1 minute Respond individually	500V AC for 1 minute	500V AC for 1 minute Respond individually	500V AC for 1 minute	
Mechanical performance	Terminal strength	—	3N for 1 minute				110N for 1 minute	3N for 1 minute
	Actuator strength	20N						
Durability	Operating life without load	300,000 cycles 1Ω max.		300,000 cycles 300,000 cycles 1Ω max.	300,000 cycles 1Ω max.	300,000 cycles 300,000 cycles 1Ω max. 1,000,000 cycles 3Ω max.	100,000cycles 1Ω max.	300,000 cycles 200mΩ max.
	Operating life with load Rating(max.) (Resistive load)	300,000 cycles 1Ω max.		300,000 cycles 1Ω max. Respond individually	300,000 cycles 1Ω max.	300,000 cycles 1Ω max. 1,000,000 cycles 3Ω max. Respond individually	100,000cycles 1Ω max.	300,000 cycles 200mΩ max.
Environmental performance	Cold	-40°C 500h						
	Dry heat	85°C 500h						
	Damp heat	60°C, 90 to 95%RH 500h						
Automotive		●	●	●	●	●	●	●

### ⚠ Note

● Indicates applicability to all products in the series, while ○ indicates applicability to some products in the series.

# Detector Switches

Series		SPVQA	SPVQC	SPVQF	SSCN	SDDH
Photo						
Features/Type		Water-proof type (Fork terminals)	Water-proof type Two-pole fast switching type (surface mount)		Water-proof type	
Operation type		Two-way output type				Push
Water-proof		●	●	●	●	●
Dust-proof		●	●	●	●	●
IP standard		IP6K7	IP6K7	IP6K7	IP6K7	IP6K8
Dimensions (mm)		6.4×15.2×7.95	7.4×15.4×7.5	6.3×8.5×7.0	5.0×13.0×15.0	28.5×9.0×24.3
Poles		1	2		1	
Positions		1 2	2		1	
Operating force		1±0.5N		1.8N max.	2N max.	4.6N max.
Operating temperature range		-40°C to +85°C		-40°C to +90°C	-40°C to +85°C	-15°C to +80°C
Rating(max.)/(min.) (Resistive load)		0.1A 12V DC/ 50μA 5V DC	50mA 18V DC/50μA 5V DC		0.1A 12V DC/ 100μA 5V DC	4.5A 12V DC/ 10mA 12V DC
Electrical performance	Contact resistance (Initial/After operating life)	500mΩ max./ 1Ω max.	75mΩ max./ 200mΩ max.	75mΩ max./ 2Ω max.	500mΩ max./1Ω max.	
	Insulation resistance	100MΩ min. 500V DC	100MΩ min. 250V DC		100MΩ min. 500V DC	10MΩ min. 500V DC
	Voltage proof	500V AC for 1 minute	250V AC for 1 minute		500V AC for 1 minute	
Mechanical performance	Terminal strength	3N for 1 minute		5±1N for 10±1S	3N for 1 minute	Slider pull-out strength: 100N min
	Actuator strength	20N			10N	—
Durability	Operating life without load	300,000 cycles 1Ω max.	300,000 cycles 200mΩ max.	300,000 cycles 2Ω max.	100,000 cycles 1Ω max.	
	Operating life with load Rating(max.) (Resistive load)	300,000 cycles 1Ω max.	300,000 cycles 200mΩ max.	300,000 cycles 2Ω max.	100,000 cycles 1Ω max.	
Environmental performance	Cold	-40°C 500h				-15°C 96h
	Dry heat	85°C 500h		90°C 500h	85°C 500h	80°C 96h
	Damp heat	60°C, 90 to 95%RH 500h				40°C, 90 to 95%RH 96h
Automotive		●	●	●	●	●

### ⚠ Note

● Indicates applicability to all products in the series, while ○ indicates applicability to some products in the series.

## Compact Two-way Operation SPVS Series

Compact, thin-profile type with a body height of 1.0mm, 3.3×3.5mm, offering N/O & N/C two-circuit varieties.

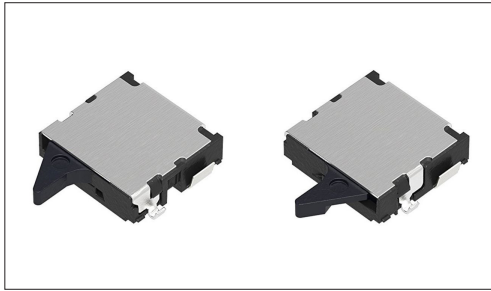

 Automotive

- Rating(max.)/(min.)(Resistive load): 1mA 5V DC/50 $\mu$ A 3V DC
- Contact resistance(Initial/After operating life): 2 $\Omega$  max./5 $\Omega$  max.
- Operating life without load: 50,000 cycles
- Operating life with load Rating(max.)(Resistive load):  
50,000 cycles 5 $\Omega$  max.

Applications: Mobile: Smartphones, tablets, Headsets, wearables,  
Notebooks, peripherals  
Energy\_Industrial: Robots, drones, Industrial equipment,  
Converters  
Game: Home handheld consoles, Virtual/augmented reality  
Healthcare: Healthcare equipment, Nursing care  
equipment, Analysis, test equipment  
Audio\_TV: Visual, Audio, Cameras  
Automotive: Navigation/audio systems, HVAC

### Product List

Products No.	Poles	Positions	Operating force	Terminal type	Lever length	Operating direction	Circuit	Location lug	Dimensions (W×D×H) (mm)	Water-proof	Dust-proof	Automotive	Drawing No.
SPVS310100	1	1	0.35N max.	For PC board (Reflow)	Standard	Right	N/O	With	3.3×3.5×1.0	—	—	●	1
SPVS310200	1	1	0.35N max.	For PC board (Reflow)	Standard	Right	N/O	Without	3.3×3.5×1.0	—	—	●	2
SPVS320100	1	1	0.35N max.	For PC board (Reflow)	Standard	Right	N/C	With	3.3×3.5×1.0	—	—	●	3
SPVS320200	1	1	0.35N max.	For PC board (Reflow)	Standard	Right	N/C	Without	3.3×3.5×1.0	—	—	●	4
SPVS410100	1	1	0.35N max.	For PC board (Reflow)	Standard	Left	N/O	With	3.3×3.5×1.0	—	—	●	5
SPVS410200	1	1	0.35N max.	For PC board (Reflow)	Standard	Left	N/O	Without	3.3×3.5×1.0	—	—	●	6
SPVS420100	1	1	0.35N max.	For PC board (Reflow)	Standard	Left	N/C	With	3.3×3.5×1.0	—	—	●	7
SPVS420200	1	1	0.35N max.	For PC board (Reflow)	Standard	Left	N/C	Without	3.3×3.5×1.0	—	—	●	8
SPVS360100	1	1	0.35N max.	For PC board (Reflow)	Long	Right	N/C	With	3.3×3.5×1.0	—	—	●	9
SPVS360200	1	1	0.35N max.	For PC board (Reflow)	Long	Right	N/C	Without	3.3×3.5×1.0	—	—	●	10

### Note

1. This catalog shows only outline specifications. When using the products, please obtain formal specifications for supply.
2. Please place purchase orders per minimum order unit (integer).
3. This products can be used in vehicles.  
Although these products are designed to perform over a wide operating temperature range, please ensure that you receive and read the formal delivery specifications before use.
4. For the Terminal Layout, please check our website.

Compact Two-way Operation  
**SPVS Series**

■ Packing Specifications

Taping

Number of packages (pcs.)			Tape width (mm)	Export package measurements (mm)
1 reel	1 case / Japan	1 case / export packing		
5,000	10,000	20,000	16	417 x 409 x 139

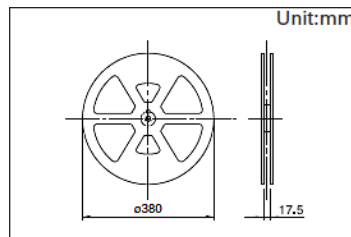

**Drawing No.1**

■ Dimensions

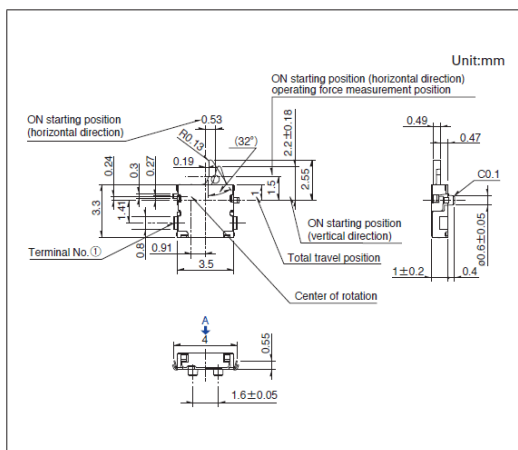

■ Land Dimensions

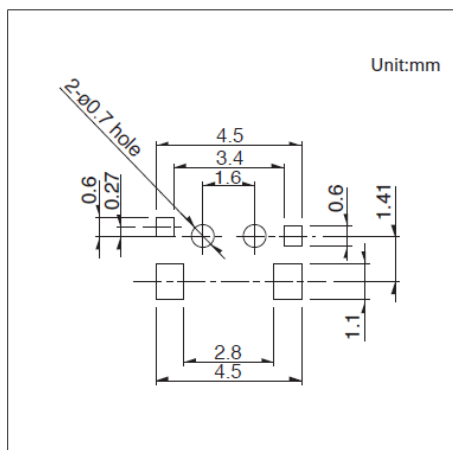

■ Circuit Diagram

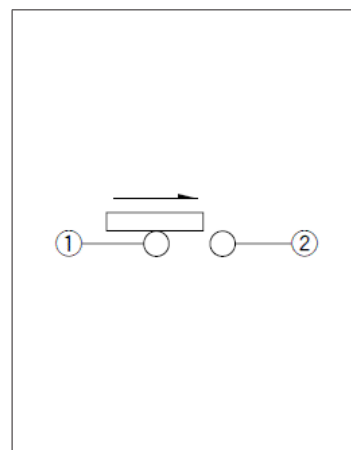

Viewed from direction A in the dimensions.

**Drawing No.2**

■ Dimensions

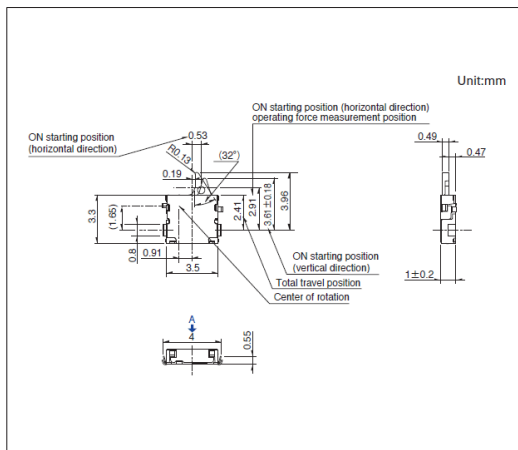

■ Land Dimensions

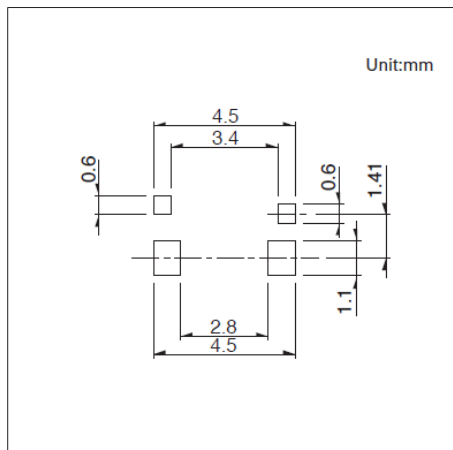

■ Circuit Diagram

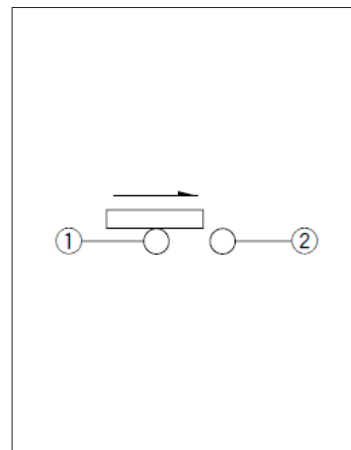

Viewed from direction A in the dimensions.

Compact Two-way Operation  
SPVS Series

Drawing No.3

■ Dimensions

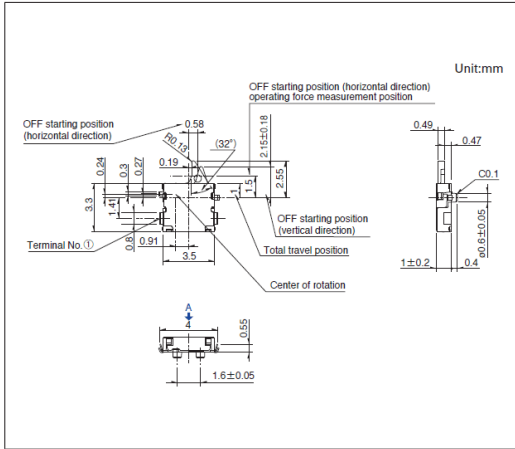

■ Land Dimensions

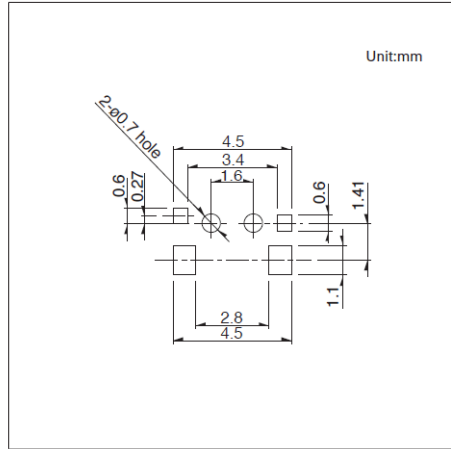

■ Circuit Diagram

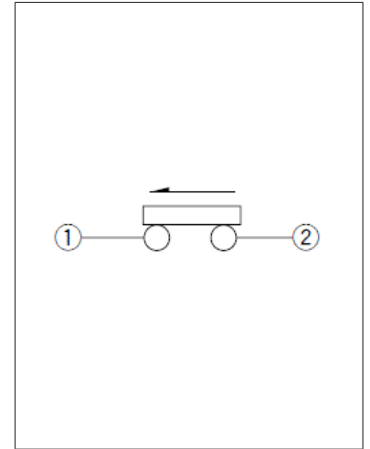

Viewed from direction A in the dimensions.

Drawing No.4

■ Dimensions

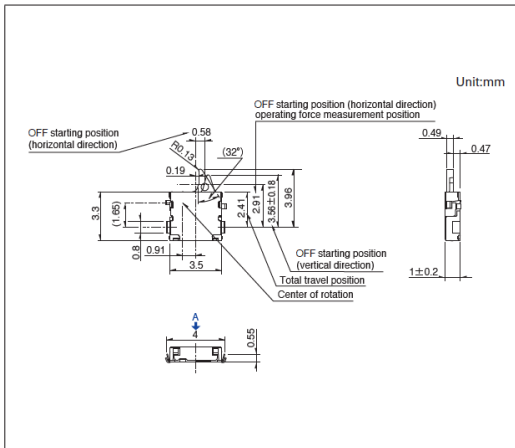

■ Land Dimensions

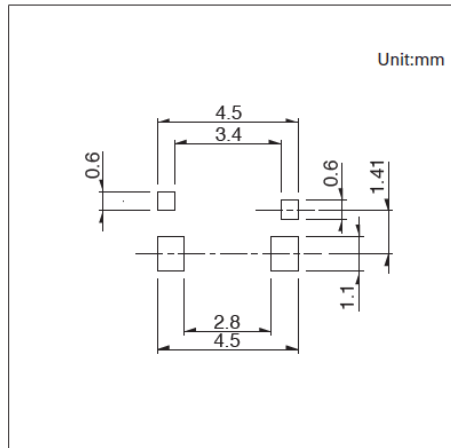

■ Circuit Diagram

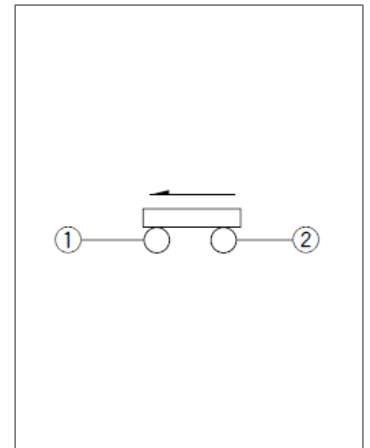

Viewed from direction A in the dimensions.

Drawing No.5

■ Dimensions

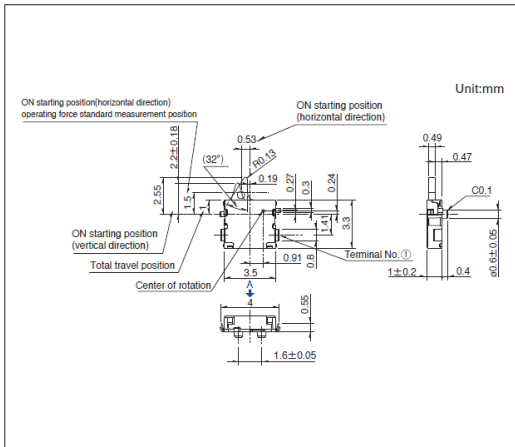

■ Land Dimensions

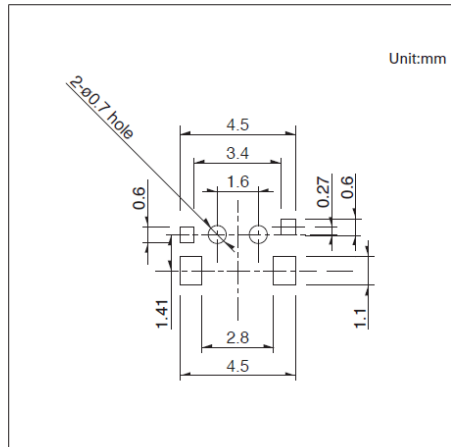

■ Circuit Diagram

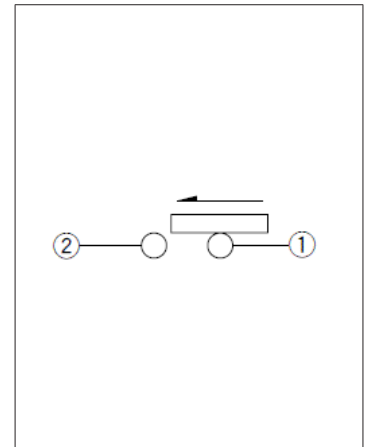

Viewed from direction A in the dimensions.

Compact Two-way Operation  
SPVS Series

Drawing No.6

■ Dimensions

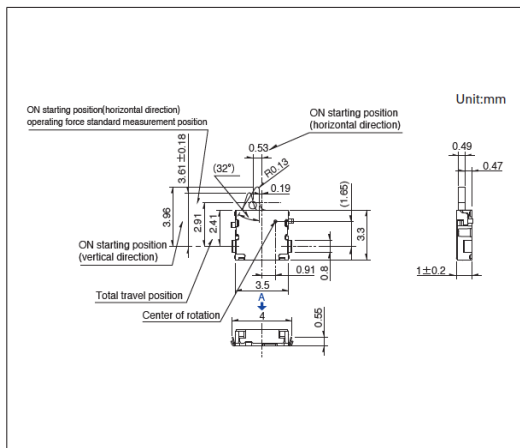

■ Land Dimensions

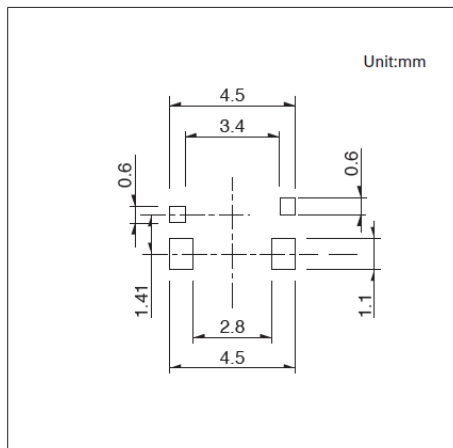

■ Circuit Diagram

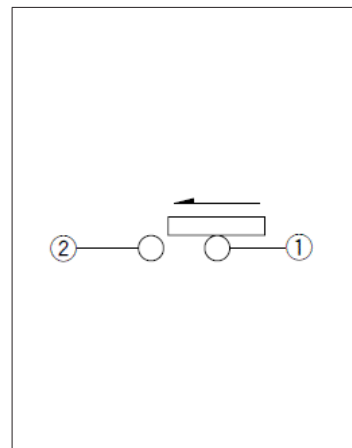

Viewed from direction A in the dimensions.

Drawing No.7

■ Dimensions

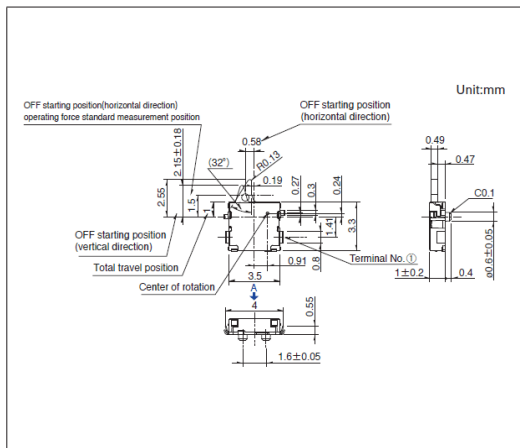

■ Land Dimensions

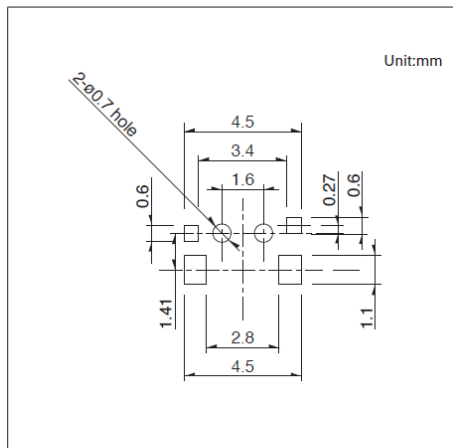

■ Circuit Diagram

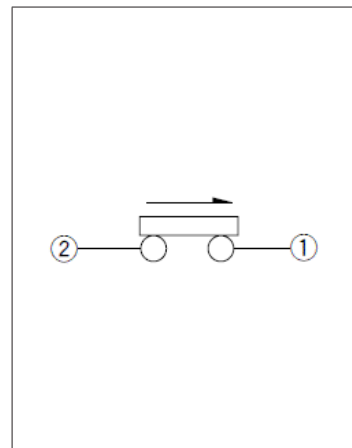

Viewed from direction A in the dimensions.

Drawing No.8

■ Dimensions

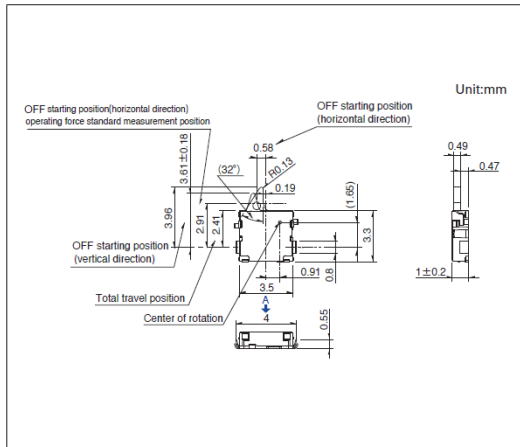

■ Land Dimensions

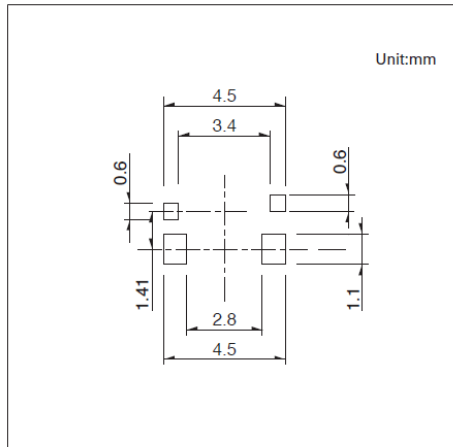

■ Circuit Diagram

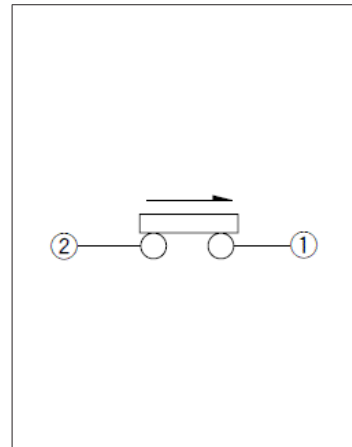

Viewed from direction A in the dimensions.

**Drawing No.9**

■ Dimensions

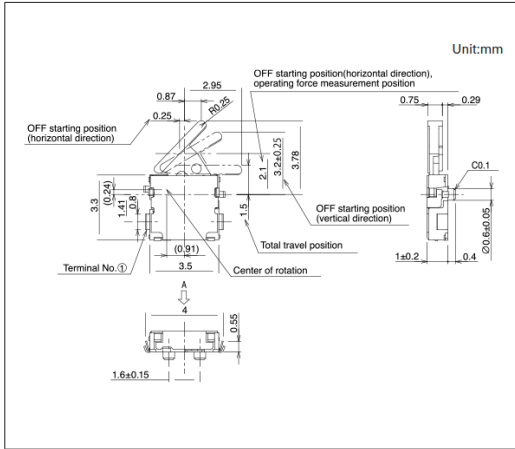

■ Land Dimensions

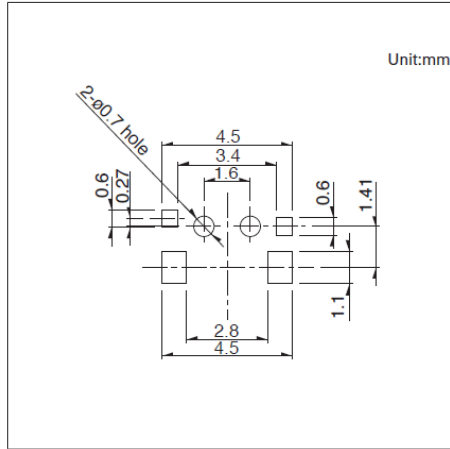

■ Circuit Diagram

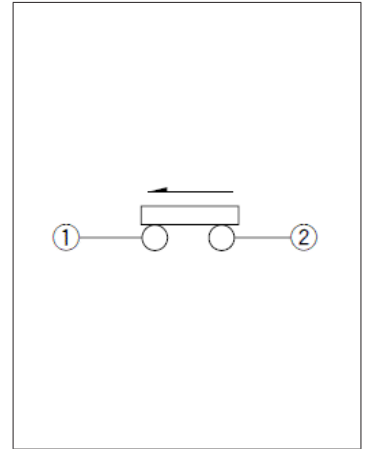

Viewed from direction A in the dimensions.

**Drawing No.10**

■ Dimensions

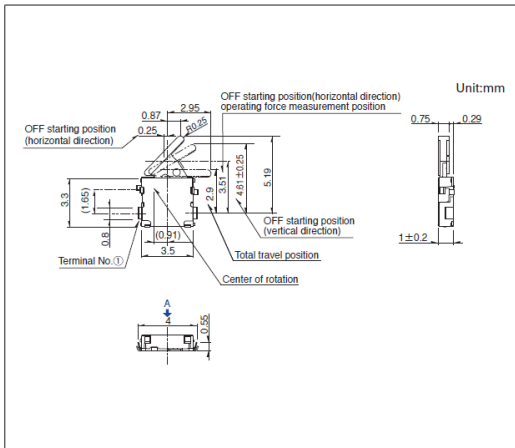

■ Land Dimensions

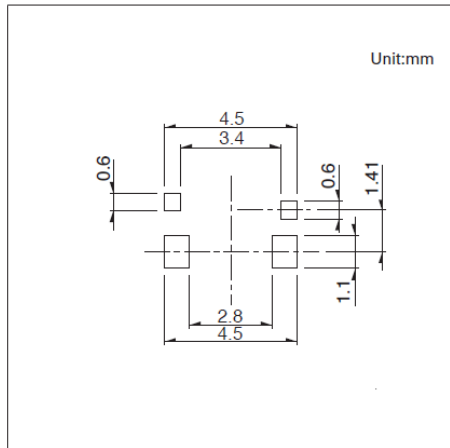

■ Circuit Diagram

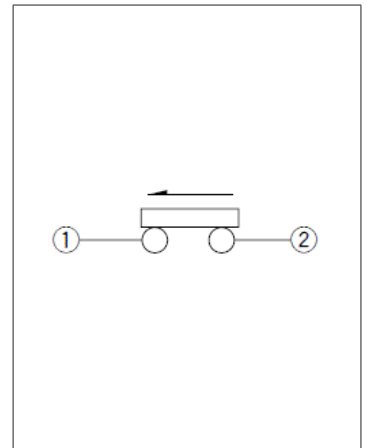

Viewed from direction A in the dimensions.

## Low-profile Two-way Operation SPVN Series

Thin-profile type with a body height of 1.0mm, 3.6×3.8mm.



 Automotive

- Rating(max.)/(min.)(Resistive load): 1mA 5V DC/50μA 3V DC
- Contact resistance(Initial/After operating life): 2Ω max./5Ω max.
- Operating life without load: 50,000 cycles
- Operating life with load Rating(max.)(Resistive load):  
50,000 cycles 5Ω max.

Applications: Mobile: Smartphones, tablets, Headsets, wearables,  
Notebooks, peripherals  
Healthcare: Healthcare equipment  
Audio\_TV: Visual, Audio, Cameras  
Automotive: Navigation/audio systems, HVAC

### Product List

Products No.	Poles	Positions	Operating force	Terminal type	Lever length	Operating direction	Location lug	Dimensions (W×D×H) (mm)	Water-proof	Dust-proof	Automotive	Drawing No.
SPVN110107	1	1	0.35N max.	For PC board (Reflow)	Standard	Right	With	3.6×3.8×1.0	—	—	●	1
SPVN120104	1	1	0.35N max.	For PC board (Reflow)	Standard	Right	Without	3.6×3.8×1.0	—	—	●	2
SPVN210106	1	1	0.35N max.	For PC board (Reflow)	Standard	Left	With	3.6×3.8×1.0	—	—	●	3
SPVN220103	1	1	0.35N max.	For PC board (Reflow)	Standard	Left	Without	3.6×3.8×1.0	—	—	●	4
SPVN310101	1	1	0.35N max.	For PC board (Reflow)	Long	Right	With	3.6×3.8×1.0	—	—	●	5
SPVN320101	1	1	0.35N max.	For PC board (Reflow)	Long	Right	Without	3.6×3.8×1.0	—	—	●	6
SPVN410101	1	1	0.35N max.	For PC board (Reflow)	Long	Left	With	3.6×3.8×1.0	—	—	●	7
SPVN420101	1	1	0.35N max.	For PC board (Reflow)	Long	Left	Without	3.6×3.8×1.0	—	—	●	8

### Note

1. This catalog shows only outline specifications. When using the products, please obtain formal specifications for supply.
2. Please place purchase orders per minimum order unit (integer).
3. This products can be used in vehicles.  
Although these products are designed to perform over a wide operating temperature range, please ensure that you receive and read the formal delivery specifications before use.
4. For the Terminal Layout, please check our website.

### Packing Specifications

#### Taping

Number of packages (pcs.)			Tape width (mm)	Export package measurements (mm)
1 reel	1 case / Japan	1 case / export packing		
5,000	10,000	20,000	16	417 x 409 x 139

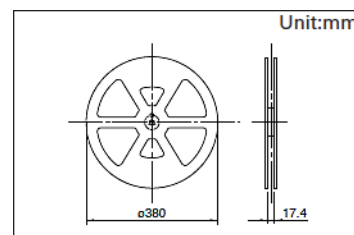



Low-profile Two-way Operation  
**SPVN Series**

**Drawing No.4**

■ Dimensions

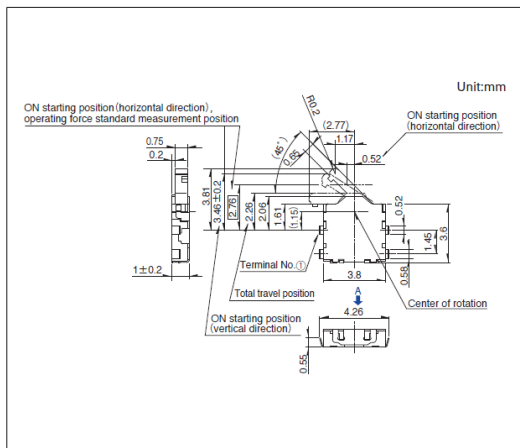

■ Land Dimensions

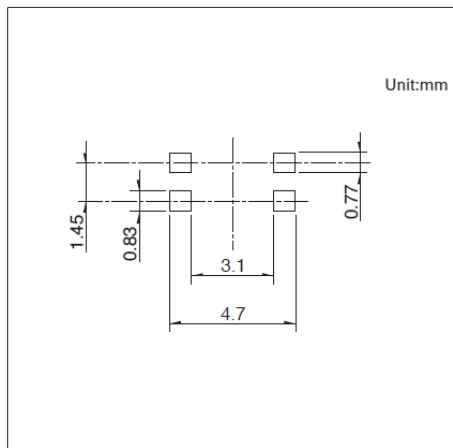

■ Circuit Diagram

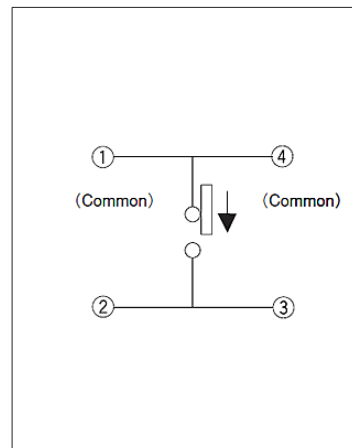

Viewed from direction A in the dimensions.

**Drawing No.5**

■ Dimensions

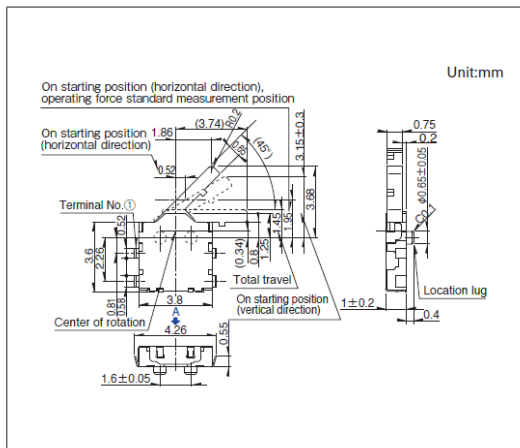

■ Land Dimensions

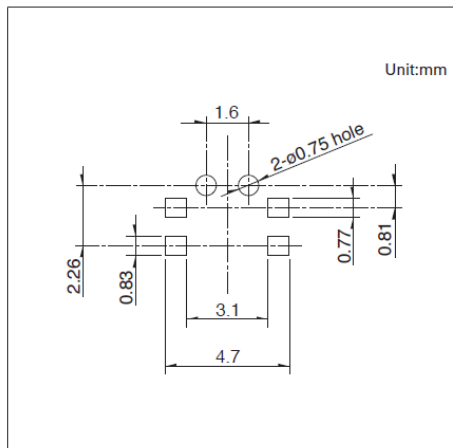

■ Circuit Diagram

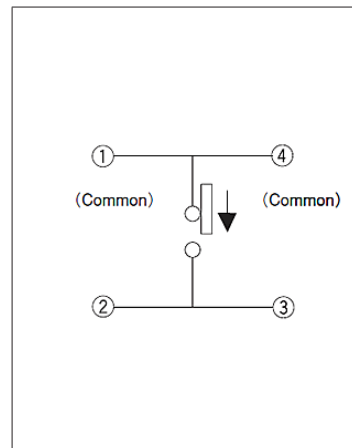

Viewed from direction A in the dimensions.

**Drawing No.6**

■ Dimensions

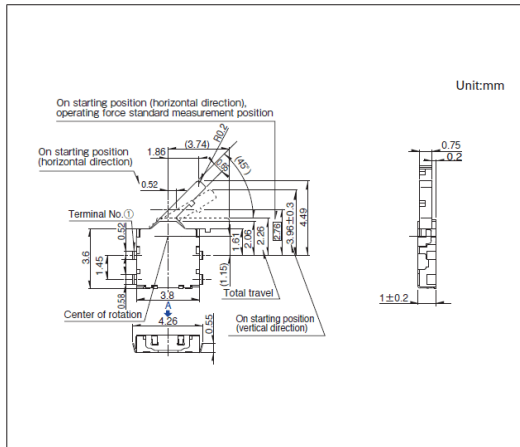

■ Land Dimensions

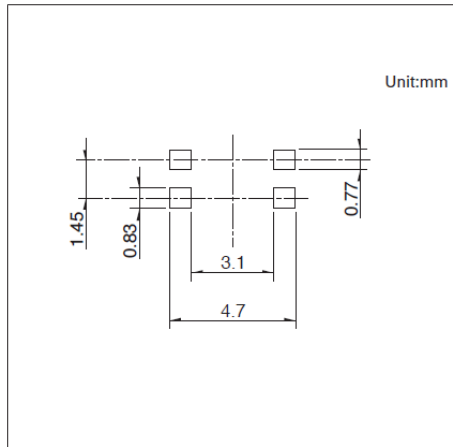

■ Circuit Diagram

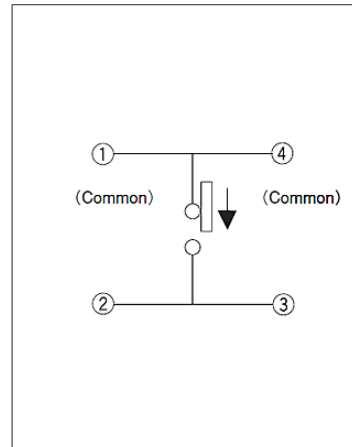

Viewed from direction A in the dimensions.



Two-way Operation

**SPVT Series**

Compact type with a body height of 1.9mm, 4.7×5.6mm, capable of two-direction detection.

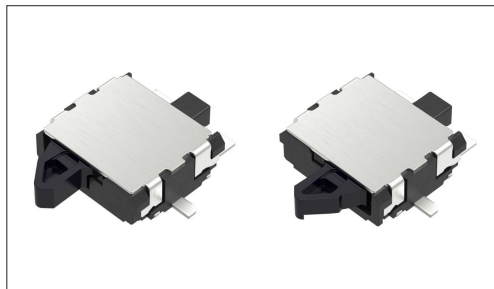
 Automotive

- Rating(max.)/(min.)(Resistive load): 50mA 20V DC/100μA 3V DC
- Contact resistance(Initial/After operating life): 500mΩ max./1Ω max.
- Operating life without load: 100,000 cycles
- Operating life with load Rating(max.)(Resistive load):  
100,000 cycles 1Ω max.

Applications: Mobile: Smartphones, tablets, Notebooks, peripherals  
 Energy\_Industrial: Robots, drones, Industrial equipment, Converters  
 Game: Home handheld consoles, Virtual/augmented reality  
 Healthcare: Healthcare equipment, Nursing care equipment, Analysis, test equipment  
 Infrastructure: Smart meters, Power distribution facilities, Data servers, Communications cables  
 Home: Major home appliances, Distribution boards, Storage batteries, Office equipment  
 Audio\_TV: Visual, Audio, Pro audio, Cameras  
 Automotive: Navigation/audio systems, HVAC

## ■ Product List

Products No.	Poles	Positions	Operating force	Terminal type	Operating direction	Location lug	Dimensions (W×D×H) (mm)	Water-proof	Dust-proof	Automotive	Drawing No.
SPVT110106	1	1	0.4N max.	For PC board (Reflow)	Right	With	4.7×5.6×1.9	—	—	●	1
SPVT130102	1	1	0.4N max.	For PC board (Reflow)	Right	With	4.7×5.6×1.9	—	—	●	2
SPVT120103	1	1	0.4N max.	For PC board (Reflow)	Right	With	4.7×5.6×1.9	—	—	●	3
SPVT140104	1	1	0.4N max.	For PC board (Reflow)	Right	With	4.7×5.6×1.9	—	—	●	4
SPVT110202	1	1	0.4N max.	For PC board (Reflow)	Right	Without	4.7×5.6×1.9	—	—	●	5
SPVT130202	1	1	0.4N max.	For PC board (Reflow)	Right	Without	4.7×5.6×1.9	—	—	●	6
SPVT120202	1	1	0.4N max.	For PC board (Reflow)	Right	Without	4.7×5.6×1.9	—	—	●	7
SPVT210104	1	1	0.4N max.	For PC board (Reflow)	Left	With	4.7×5.6×1.9	—	—	●	8
SPVT230103	1	1	0.4N max.	For PC board (Reflow)	Left	With	4.7×5.6×1.9	—	—	●	9
SPVT220103	1	1	0.4N max.	For PC board (Reflow)	Left	With	4.7×5.6×1.9	—	—	●	10
SPVT240103	1	1	0.4N max.	For PC board (Reflow)	Left	With	4.7×5.6×1.9	—	—	●	11
SPVT210202	1	1	0.4N max.	For PC board (Reflow)	Left	Without	4.7×5.6×1.9	—	—	●	12
SPVT230202	1	1	0.4N max.	For PC board (Reflow)	Left	Without	4.7×5.6×1.9	—	—	●	13
SPVT220202	1	1	0.4N max.	For PC board (Reflow)	Left	Without	4.7×5.6×1.9	—	—	●	14

 Note

1. This catalog shows only outline specifications. When using the products, please obtain formal specifications for supply.
2. Please place purchase orders for taping products per minimum order unit (1 reel or a case).
3. This products can be used in vehicles.  
Although these products are designed to perform over a wide operating temperature range, please ensure that you receive and read the formal delivery specifications before use.
4. For the Terminal Layout, please check our website.

Two-way Operation  
SPVT Series

■ Packing Specifications

Taping

Number of packages (pcs.)			Tape width (mm)	Export package measurements (mm)
1 reel	1 case / Japan	1 case / export packing		
2,500	5,000	10,000	16	417 x 409 x 139

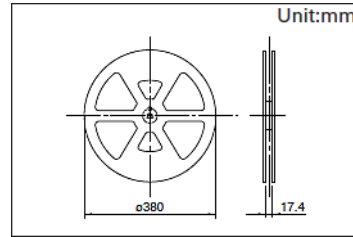

Drawing No.1

■ Dimensions

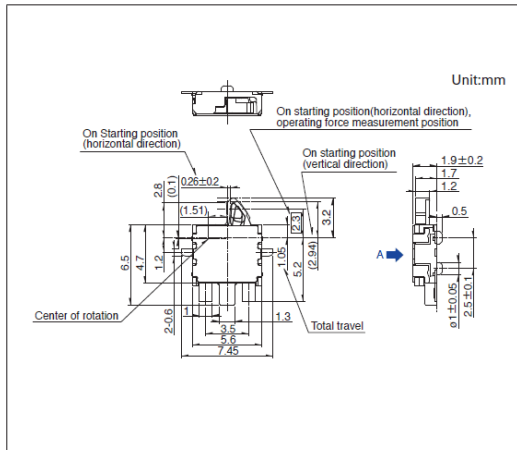

■ Land Dimensions

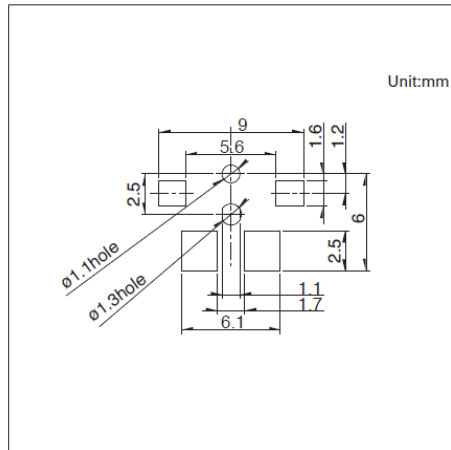

■ Circuit Diagram

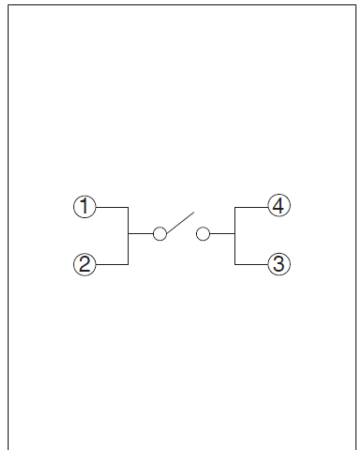

Viewed from direction A in the dimensions.

Drawing No.2

■ Dimensions

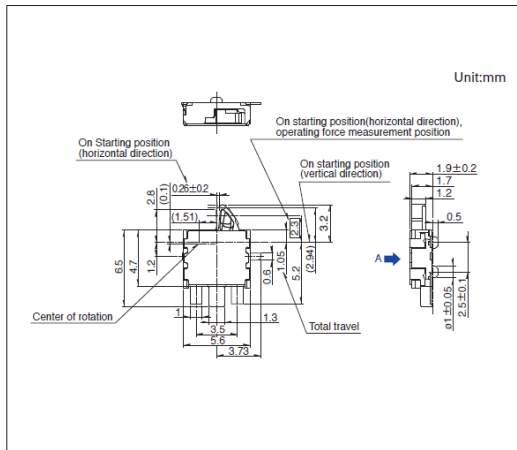

■ Land Dimensions

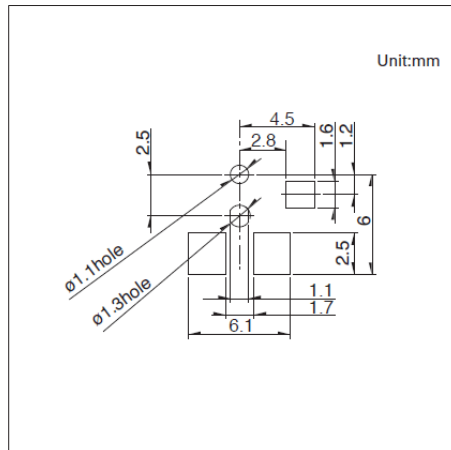

■ Circuit Diagram

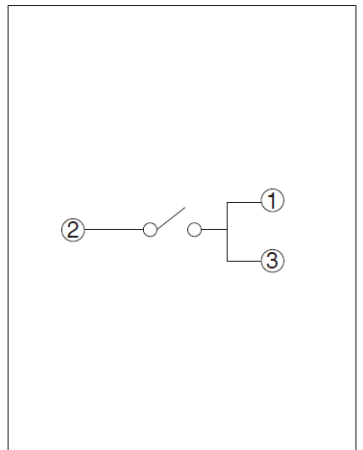

Viewed from direction A in the dimensions.

Two-way Operation  
SPVT Series

Drawing No.3

■ Dimensions

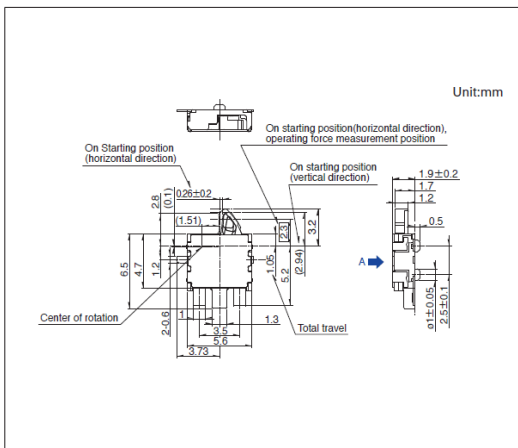

■ Land Dimensions

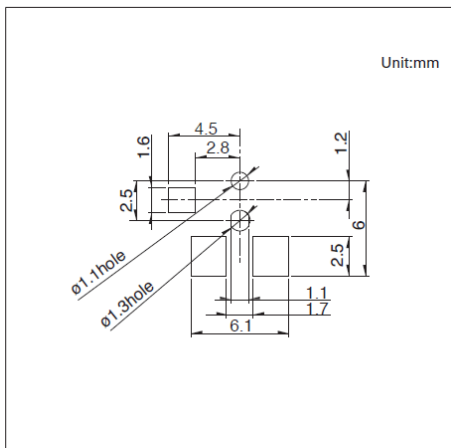

■ Circuit Diagram

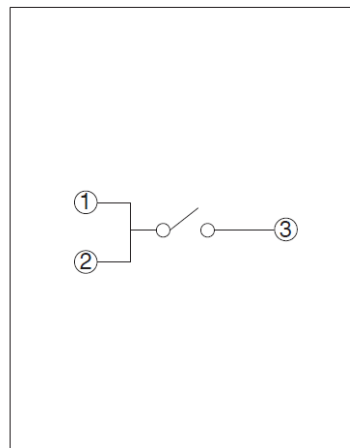

Viewed from direction A in the dimensions.

Drawing No.4

■ Dimensions

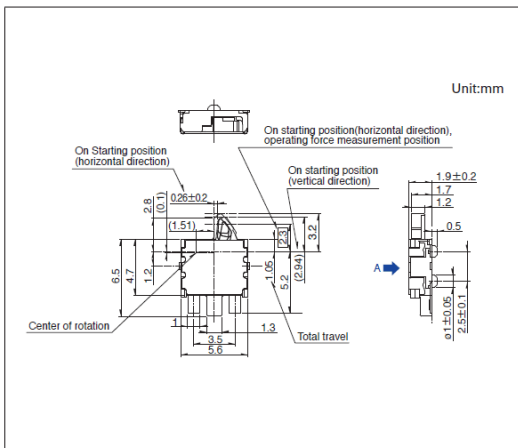

■ Land Dimensions

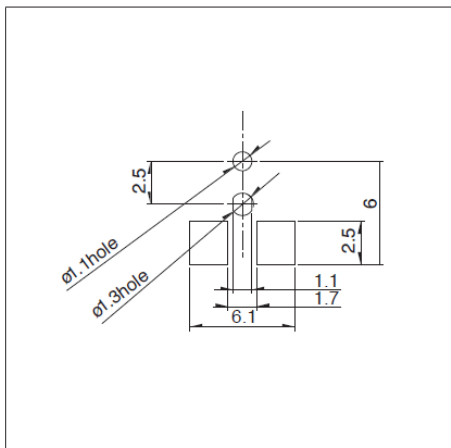

■ Circuit Diagram

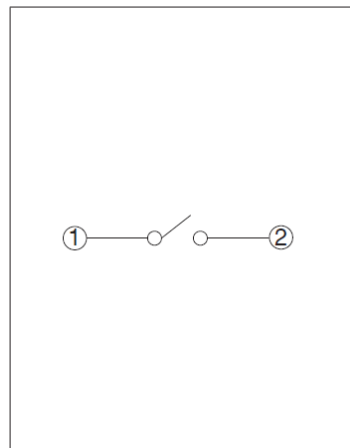

Viewed from direction A in the dimensions.

Drawing No.5

■ Dimensions

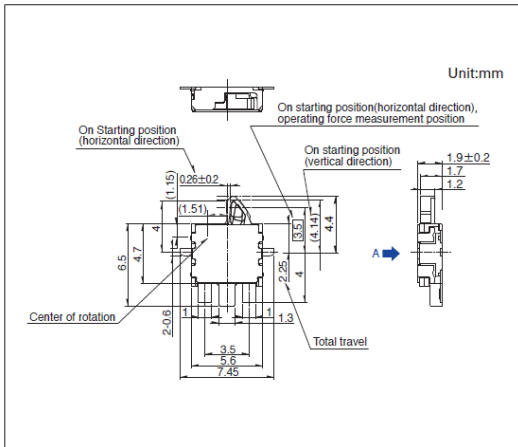

■ Land Dimensions

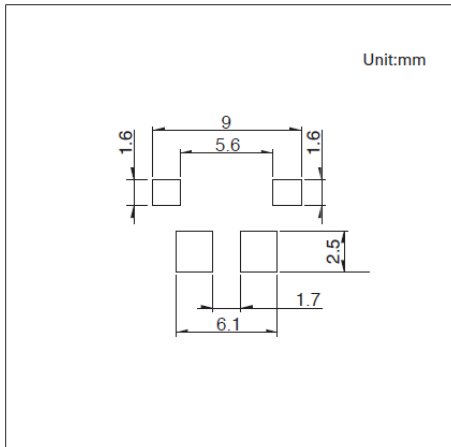

■ Circuit Diagram

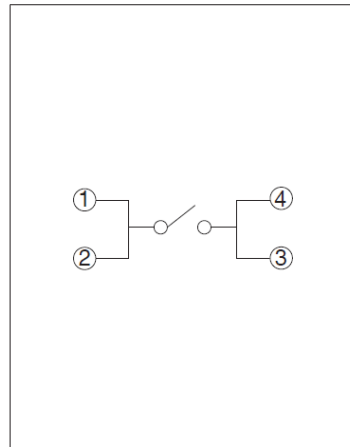

Viewed from direction A in the dimensions.

Two-way Operation  
SPVT Series

Drawing No.6

■ Dimensions

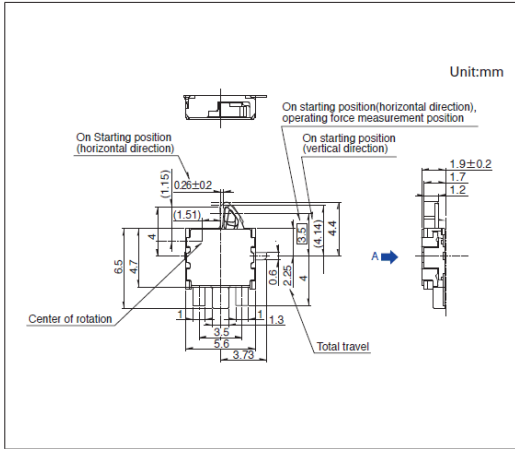

■ Land Dimensions

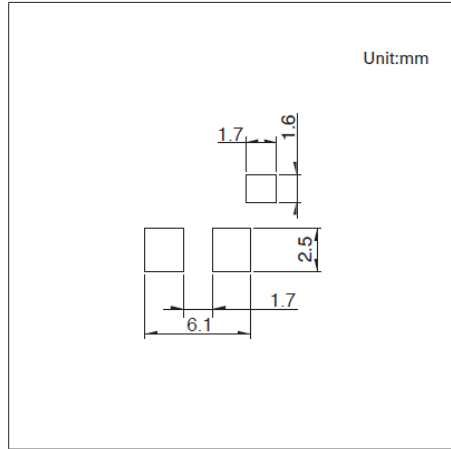

■ Circuit Diagram

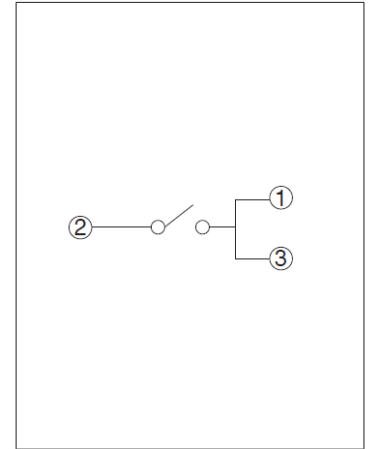

Viewed from direction A in the dimensions.

Drawing No.7

■ Dimensions

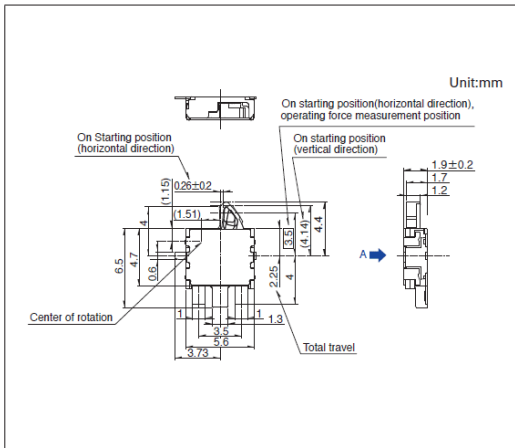

■ Land Dimensions

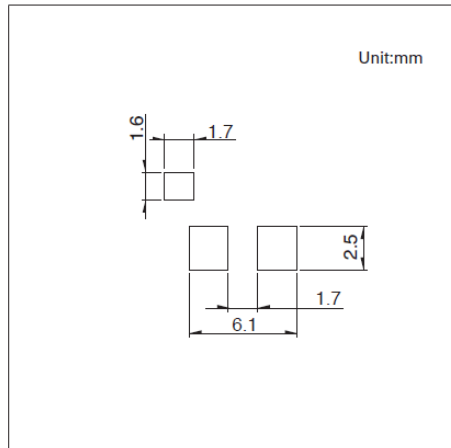

■ Circuit Diagram

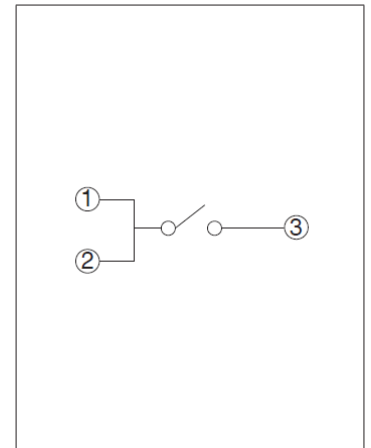

Viewed from direction A in the dimensions.

Drawing No.8

■ Dimensions

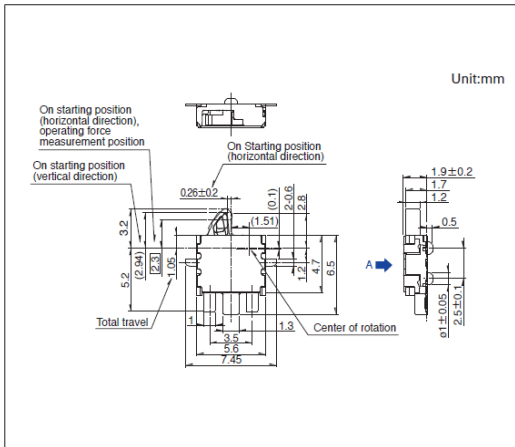

■ Land Dimensions

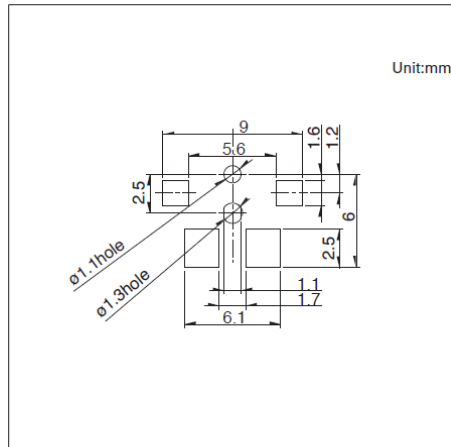

■ Circuit Diagram

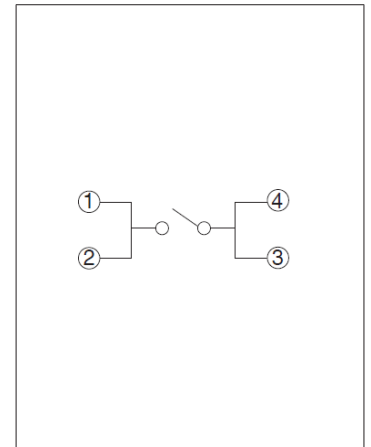

Viewed from direction A in the dimensions.

Two-way Operation  
SPVT Series

Drawing No.9

■ Dimensions

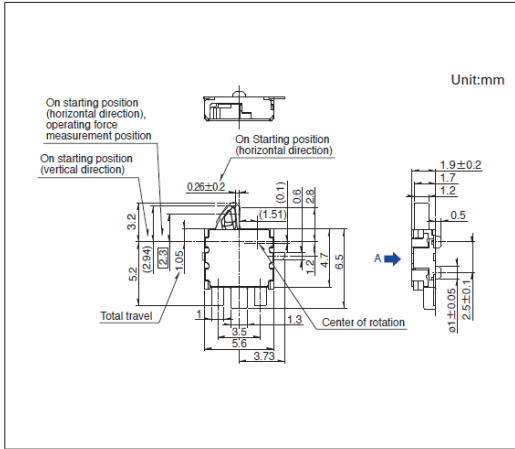

■ Land Dimensions

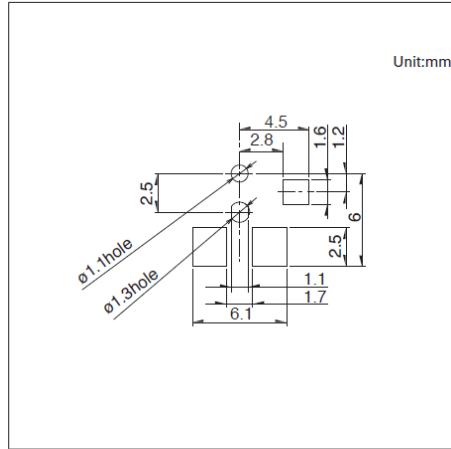

■ Circuit Diagram

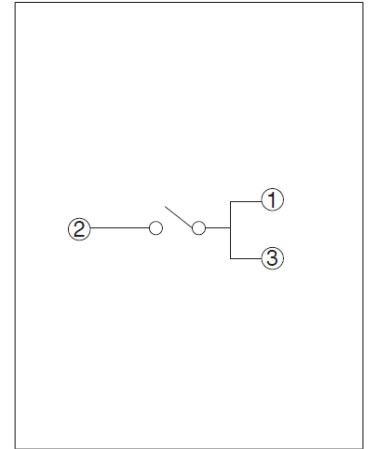

Viewed from direction A in the dimensions.

Drawing No.10

■ Dimensions

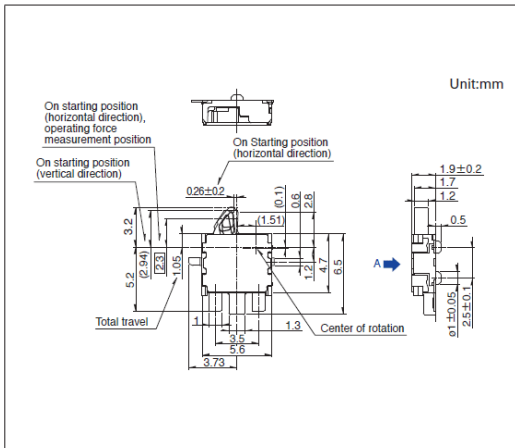

■ Land Dimensions

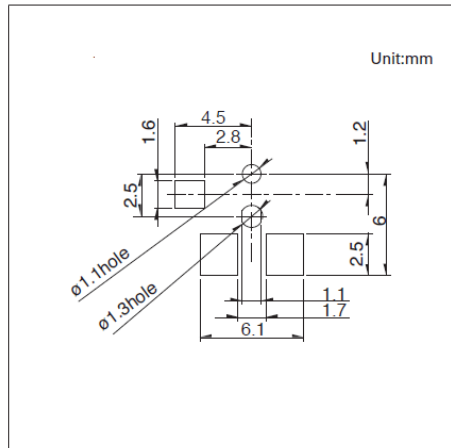

■ Circuit Diagram

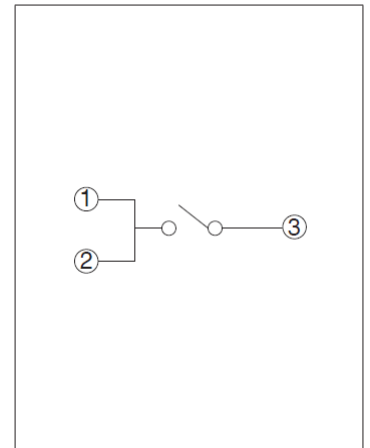

Viewed from direction A in the dimensions.

Drawing No.11

■ Dimensions

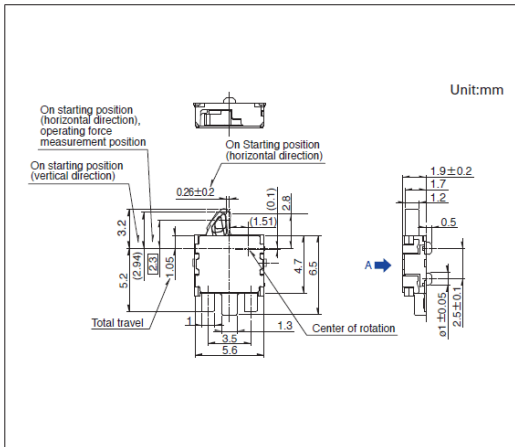

■ Land Dimensions

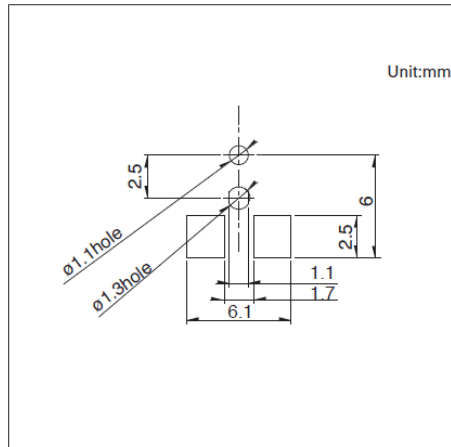

■ Circuit Diagram

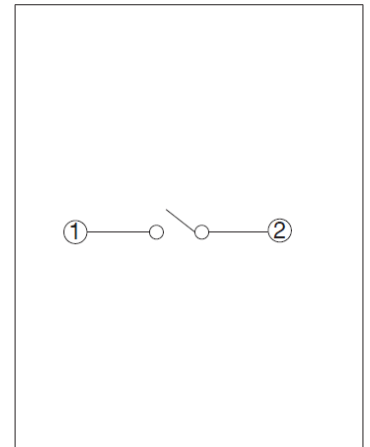

Viewed from direction A in the dimensions.

Two-way Operation  
SPVT Series

Drawing No.12

■ Dimensions

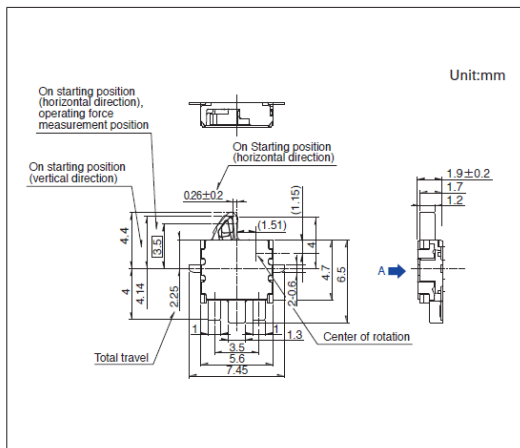

■ Land Dimensions

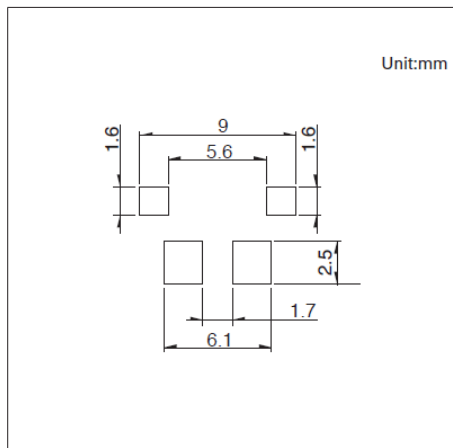

■ Circuit Diagram

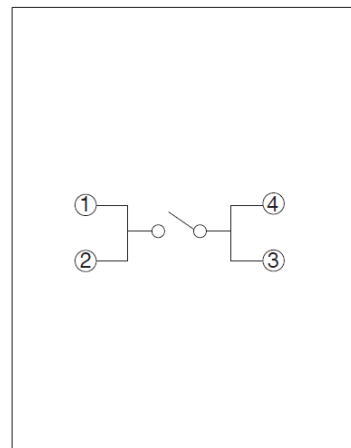

Viewed from direction A in the dimensions.

Drawing No.13

■ Dimensions

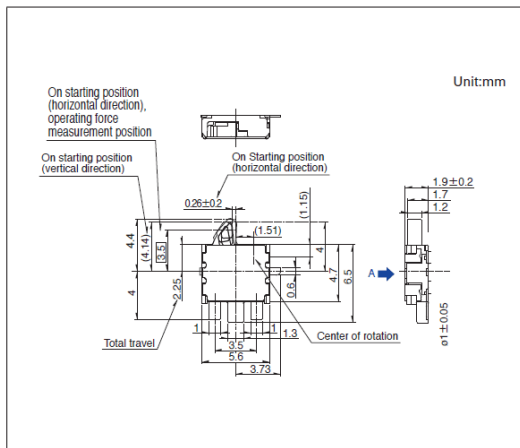

■ Land Dimensions

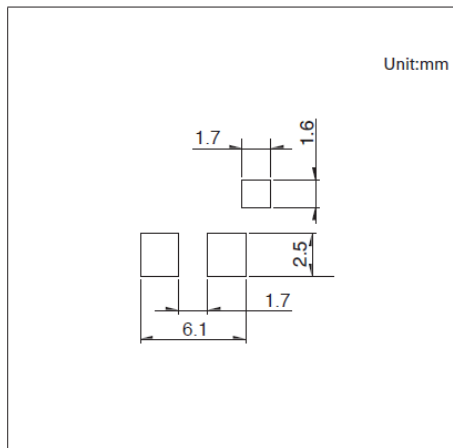

■ Circuit Diagram

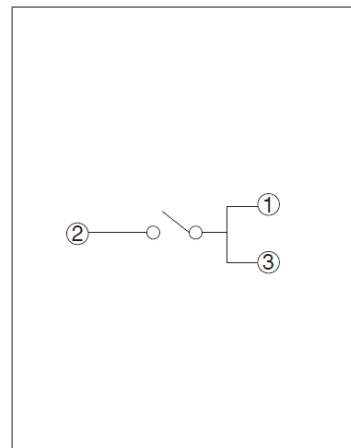

Viewed from direction A in the dimensions.

Drawing No.14

■ Dimensions

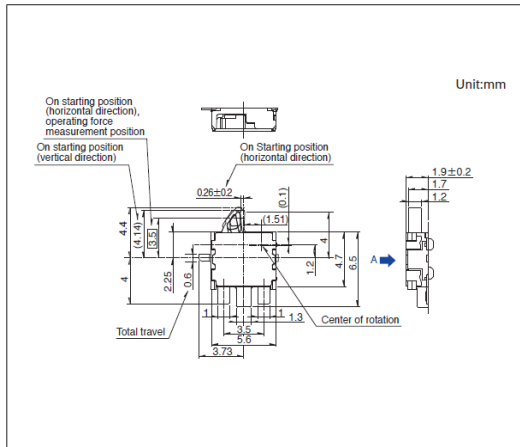

■ Land Dimensions

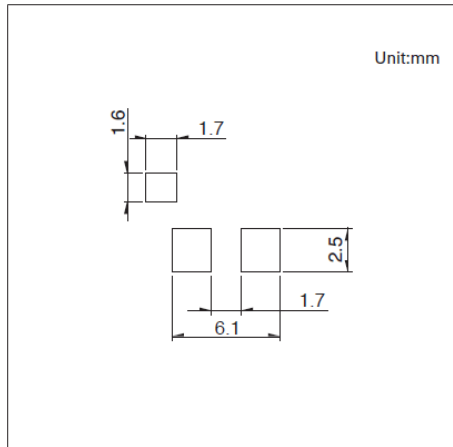

■ Circuit Diagram

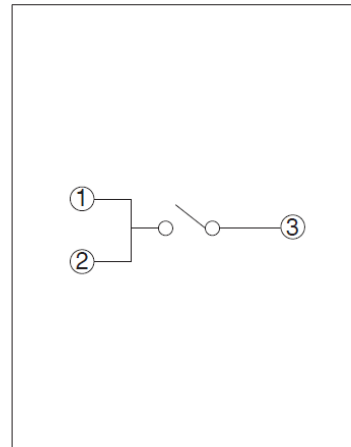

Viewed from direction A in the dimensions.

## Compact Two-way Operation SPVM Series

Compact type with a body height of 1.5mm, 3.5×2.8mm, pressable from two directions, vertical and horizontal.



 Automotive

- Rating(max.)/(min.)(Resistive load): 1mA 5V DC/50 $\mu$ A 3V DC
- Contact resistance(Initial/After operating life): 2 $\Omega$  max./5 $\Omega$  max.
- Operating life without load: 50,000 cycles
- Operating life with load Rating(max.)(Resistive load):  
50,000 cycles 5 $\Omega$  max.

Applications: Mobile: Smartphones, tablets, Notebooks, peripherals  
Healthcare: Healthcare equipment  
Audio\_TV: Cameras  
Automotive: Navigation/audio systems, HVAC

### Product List

Products No.	Poles	Positions	Operating force	Terminal type	Location lug	Dimensions (W×D×H) (mm)	Water-proof	Dust-proof	Automotive	Drawing No.
SPVM110100	1	1	0.4N max.	For PC board (Reflow)	With	2.8×3.5×1.5	—	—	●	1
SPVM110200	1	1	0.4N max.	For PC board (Reflow)	Without	2.8×3.5×1.5	—	—	●	2

### Note

1. This catalog shows only outline specifications. When using the products, please obtain formal specifications for supply.
2. Please place purchase orders per minimum order unit (integer).
3. This products can be used in vehicles.  
Although these products are designed to perform over a wide operating temperature range, please ensure that you receive and read the formal delivery specifications before use.
4. For the Terminal Layout, please check our website.

### Packing Specifications

#### Taping

Number of packages (pcs.)			Tape width (mm)	Export package measurements (mm)
1 reel	1 case / Japan	1 case / export packing		
3,000	6,000	12,000	16	417 x 409 x 139

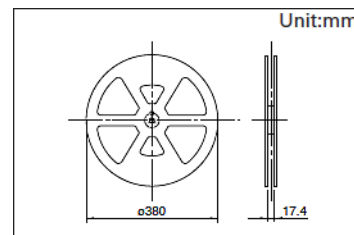

Compact Two-way Operation  
**SPVM Series**

**Drawing No.1**

■ Dimensions

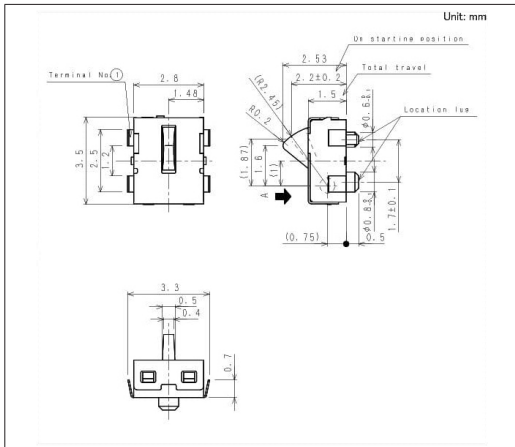

■ Land Dimensions

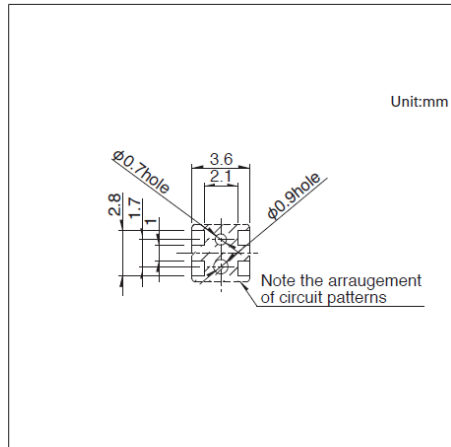

■ Circuit Diagram

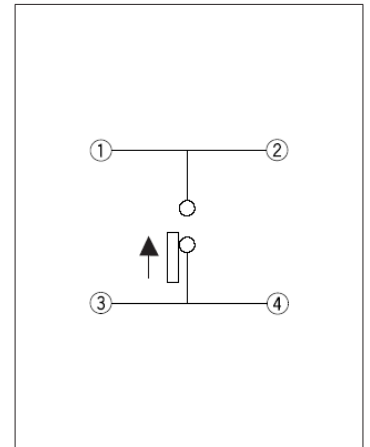

Viewed from direction A in the dimensions.

**Drawing No.2**

■ Dimensions

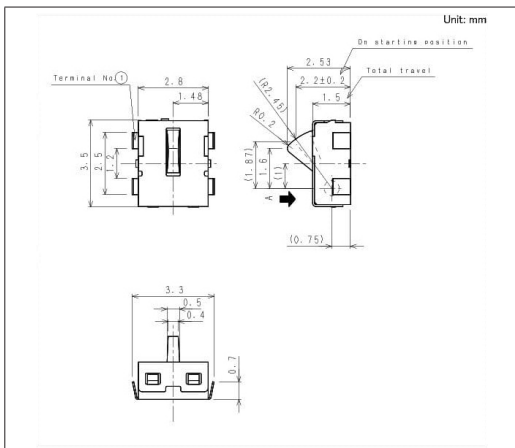

■ Land Dimensions

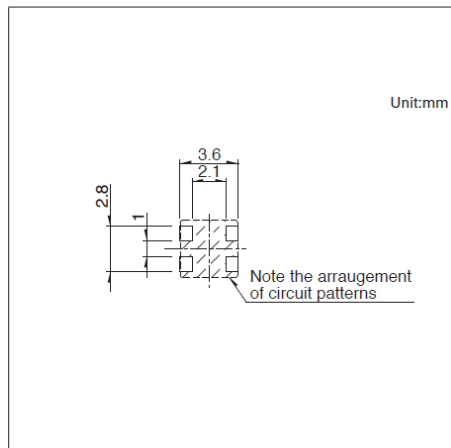

■ Circuit Diagram

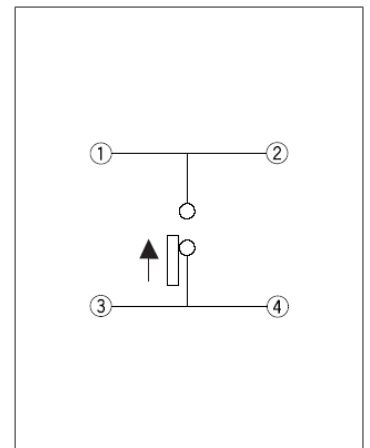

Viewed from direction A in the dimensions.

## Low-profile Lever SPVR Series

Thin-profile long-stroke type with a body height of 1.2mm, 4.2×3.6mm.

 Automotive



- Rating(max.)/(min.)(Resistive load): 1mA 5V DC/100 $\mu$ A 3V DC
- Contact resistance(Initial/After operating life): 3 $\Omega$  max./5 $\Omega$  max.
- Operating life without load: 50,000 cycles
- Operating life with load Rating(max.)(Resistive load):  
50,000 cycles 5 $\Omega$  max.

Applications: Mobile: Smartphones, tablets, Notebooks, peripherals  
Healthcare: Healthcare equipment  
Audio\_TV: Cameras  
Automotive: Navigation/audio systems, HVAC

### Product List

Products No.	Poles	Positions	Operating force	Terminal type	Total travel position	Location lug	Dimensions (W×D×H) (mm)	Water-proof	Dust-proof	Automotive	Drawing No.
SPVR110102	1	1	0.35N max.	For PC board (Reflow)	1.93	With	3.6×4.2×1.2	—	—	●	1
SPVR120102	1	1	0.35N max.	For PC board (Reflow)	1.93	Without	3.6×4.2×1.2	—	—	●	2

### Note

1. This catalog shows only outline specifications. When using the products, please obtain formal specifications for supply.
2. Please place purchase orders per minimum order unit (integer).
3. This products can be used in vehicles.  
Although these products are designed to perform over a wide operating temperature range, please ensure that you receive and read the formal delivery specifications before use.
4. For the Terminal Layout, please check our website.

### Packing Specifications

#### Taping

Number of packages (pcs.)			Tape width (mm)	Export package measurements (mm)
1 reel	1 case / Japan	1 case / export packing		
2,500	5,000	10,000	16	417 x 409 x 139

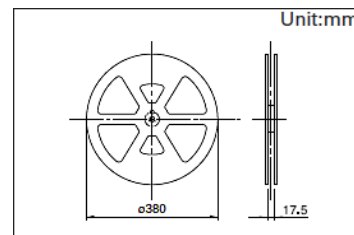

Low-profile Lever  
SPVR Series

Drawing No.1

■ Dimensions

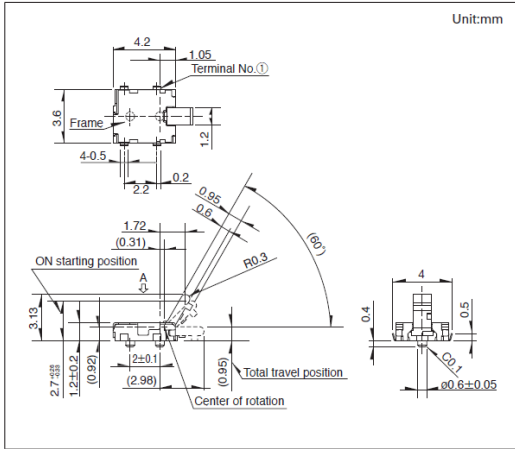

■ Land Dimensions

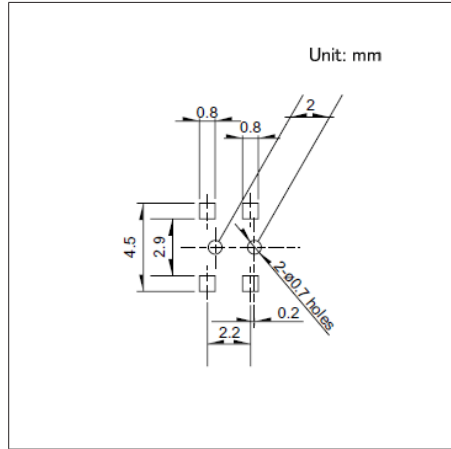

■ Circuit Diagram

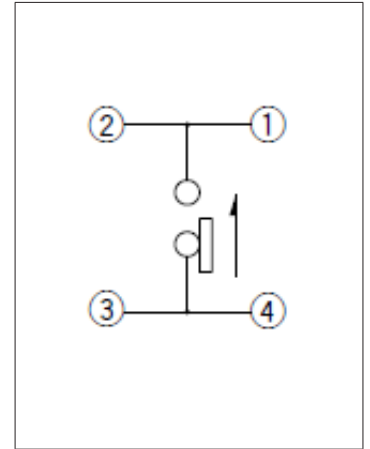

Viewed from direction A in the dimensions.

Drawing No.2

■ Dimensions

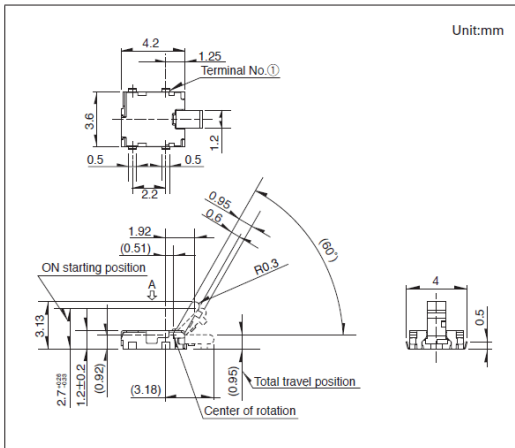

■ Land Dimensions

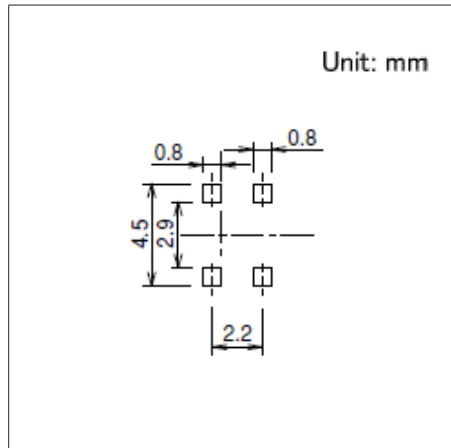

■ Circuit Diagram

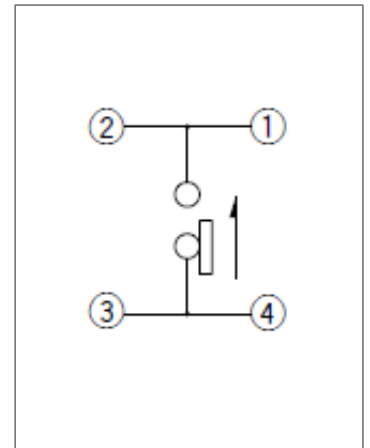

Viewed from direction A in the dimensions.

## Compact One-way Operation SPVE Series

Industry's smallest class type with dimensions of 3.4×3.0mm.

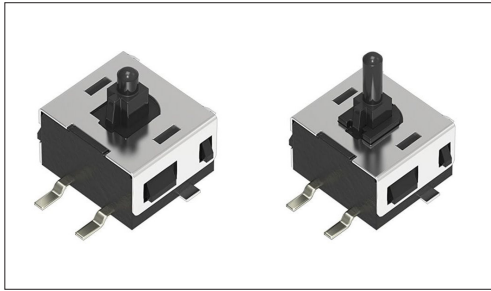

- Rating(max.)/(min.)(Resistive load):0.1A 30V DC/50μA 3V DC
- Contact resistance(Initial/After operating life):500mΩ max./1Ω max.
- Operating life without load:50,000 cycles
- Operating life with load Rating(max.)(Resistive load):  
50,000 cycles 1Ω max.

Applications: Mobile: Smartphones, tablets, Notebooks, peripherals  
Audio\_TV: Cameras

### Product List

Products No.	Poles	Positions	Operating force	Terminal type	Slider height	ON start position	Total travel position	Location lug	Dimensions (W×D×H) (mm)	Water-proof	Dust-proof	Automotive	Drawing No.
SPVE110100	1	1	0.3N max.	For PC board (Reflow)	3.8	3.5	2.5	Without	3.4×3.0×2.3	—	—	—	1
SPVE110600	1	1	0.3N max.	For PC board (Reflow)	3.8	3.5	2.5	With	3.4×3.0×2.3	—	—	—	2
SPVE110401	1	1	0.3N max.	For PC board (Reflow)	4.1	3.8	2.9	Without	3.4×3.0×2.3	—	—	—	3
SPVE110801	1	1	0.3N max.	For PC board (Reflow)	4.1	3.8	2.9	With	3.4×3.0×2.3	—	—	—	4
SPVE110200	1	1	0.3N max.	For PC board (Reflow)	4.8	4.5	3.6	Without	3.4×3.0×2.3	—	—	—	5
SPVE110900	1	1	0.3N max.	For PC board (Reflow)	4.8	4.5	3.6	With	3.4×3.0×2.3	—	—	—	6
SPVE111300	1	1	0.3N max.	For PC board (Reflow)	5.2	4.9	4.0	With	3.4×3.0×2.3	—	—	—	7
SPVE111200	1	1	0.3N max.	For PC board (Reflow)	5.5	5.2	4.3	With	3.4×3.0×2.3	—	—	—	8
SPVE210100	1	1	0.3N max.	For PC board (Reflow)	3.3	3.0	2.0	—	3.4×4.0×1.8	—	—	—	9

### ⚠ Note

1. This catalog shows only outline specifications. When using the products, please obtain formal specifications for supply.
2. Please place purchase orders for taping products per minimum order unit (1 reel or a case).
3. For the Terminal Layout, please check our website.

### Packing Specifications

#### Taping

Products No.	Number of packages(pcs.)			Tape width (mm)	Export package measurements (mm)
	1 reel	1 case / Japan	1 case / export packing		
SPVE110100 SPVE110600 SPVE110401 SPVE110801 SPVE210100	2,800	5,600	22,400	12	406×406×190
SPVE110200 SPVE110900	2,200	4,400	17,600	12	406×406×190
SPVE111300 SPVE111200	2,000	4,000	16,000	12	406×406×190

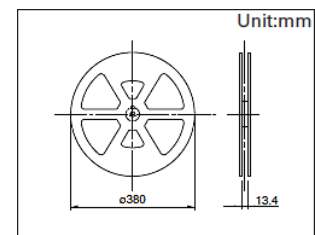

Compact One-way Operation  
SPVE Series

Drawing No.1

■ Dimensions

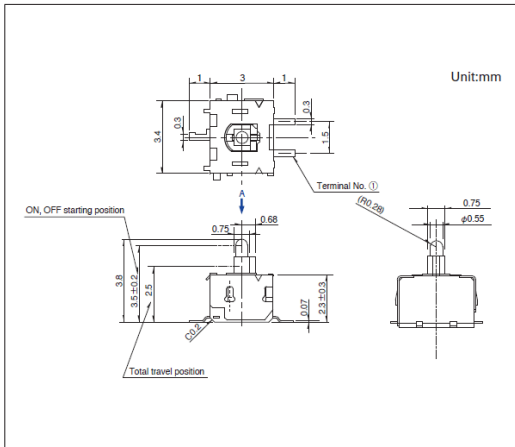

■ Land Dimensions

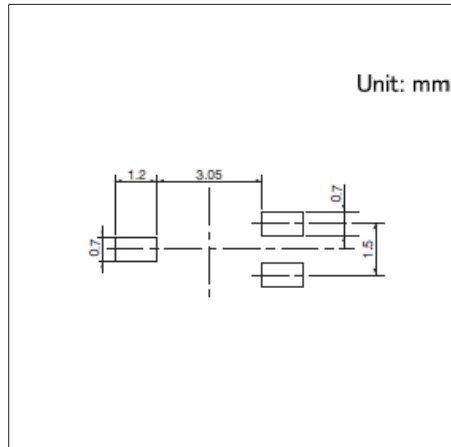

■ Circuit Diagram

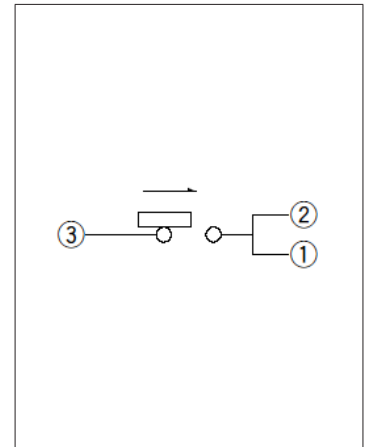

Viewed from direction A in the dimensions.

Drawing No.2

■ Dimensions

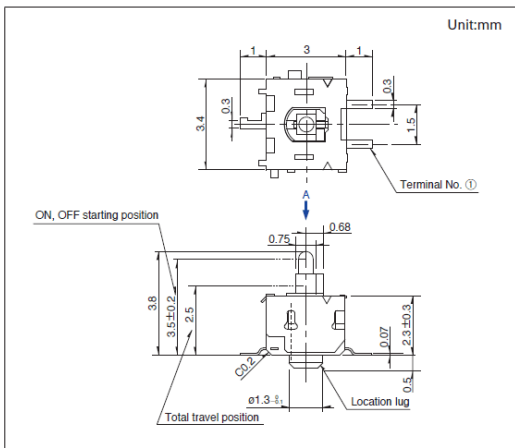

■ Land Dimensions

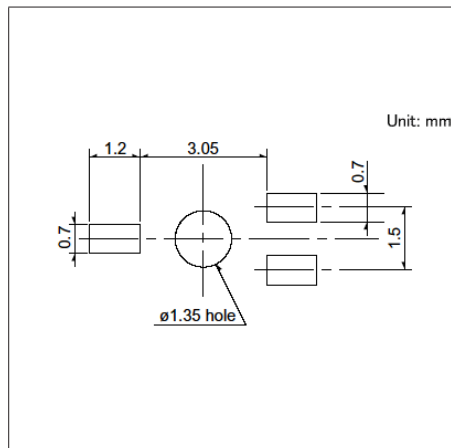

■ Circuit Diagram

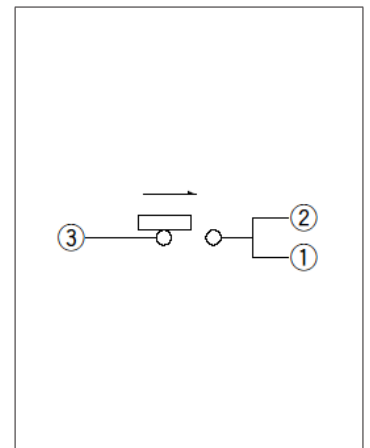

Viewed from direction A in the dimensions.

Drawing No.3

■ Dimensions

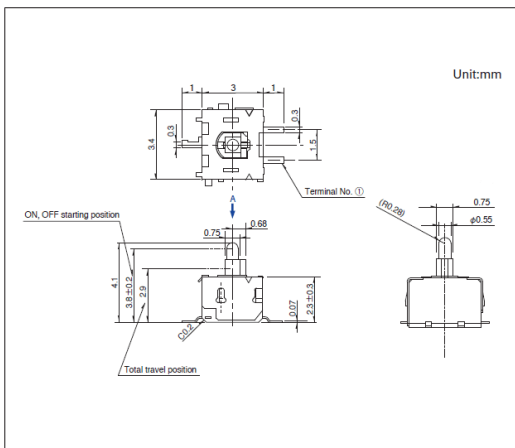

■ Land Dimensions

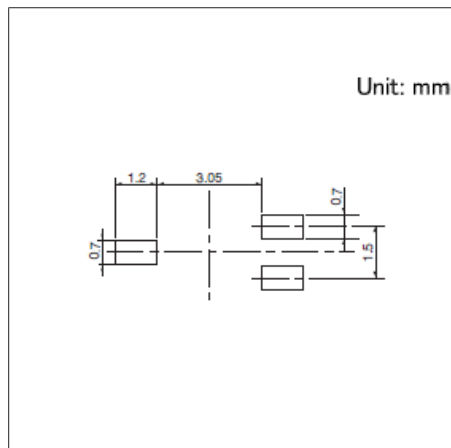

■ Circuit Diagram

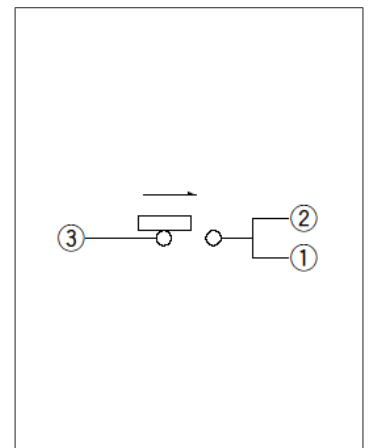

Viewed from direction A in the dimensions.

**Drawing No.4**

■ Dimensions

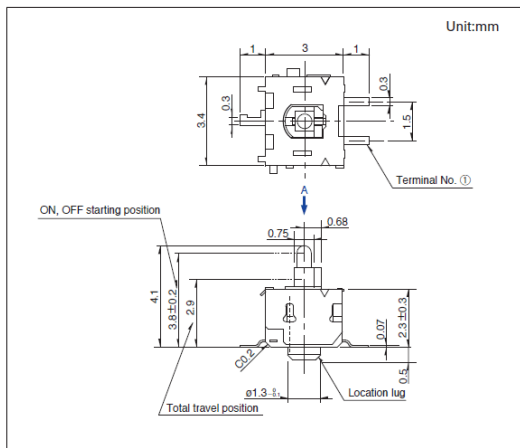

■ Land Dimensions

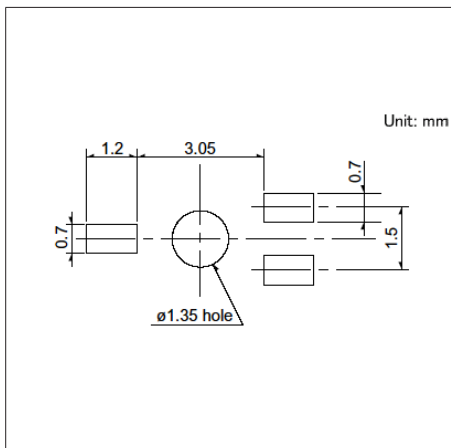

■ Circuit Diagram

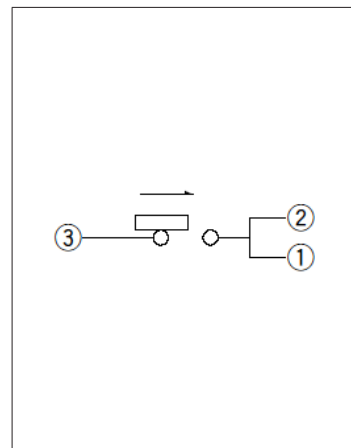

Viewed from direction A in the dimensions.

**Drawing No.5**

■ Dimensions

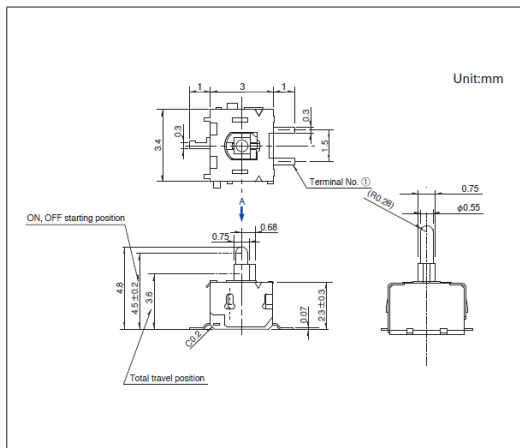

■ Land Dimensions

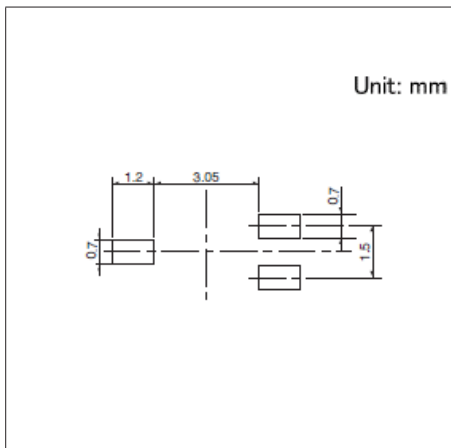

■ Circuit Diagram

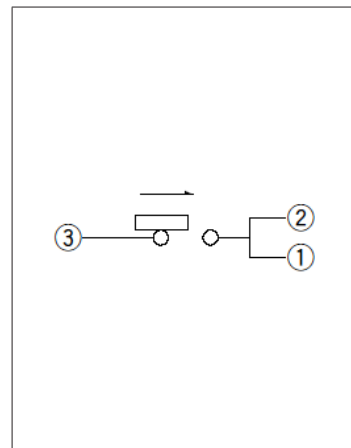

Viewed from direction A in the dimensions.

**Drawing No.6**

■ Dimensions

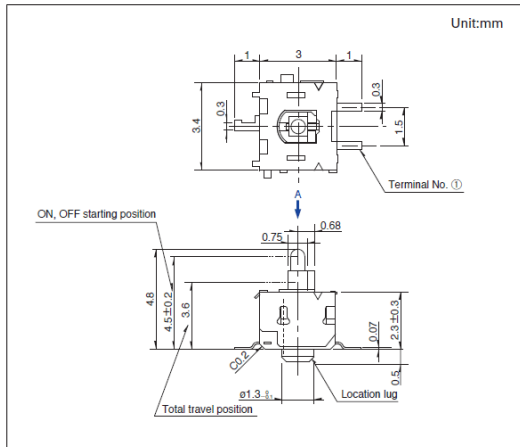

■ Land Dimensions

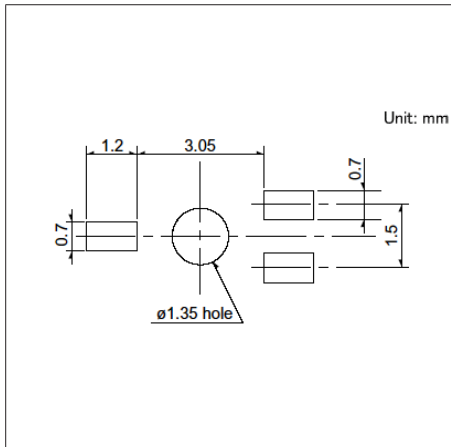

■ Circuit Diagram

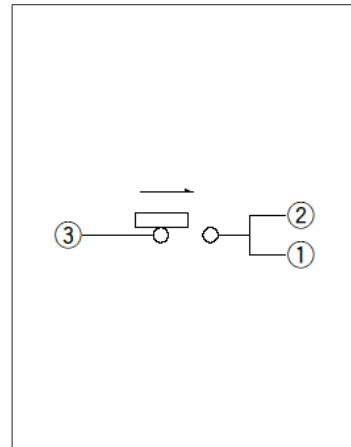

Viewed from direction A in the dimensions.

Compact One-way Operation  
**SPVE Series**

**Drawing No.7**

■ Dimensions

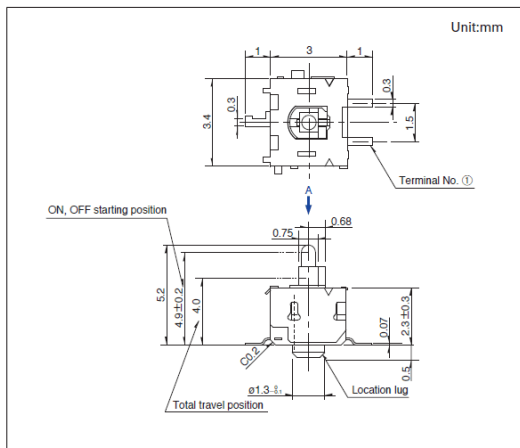

■ Land Dimensions

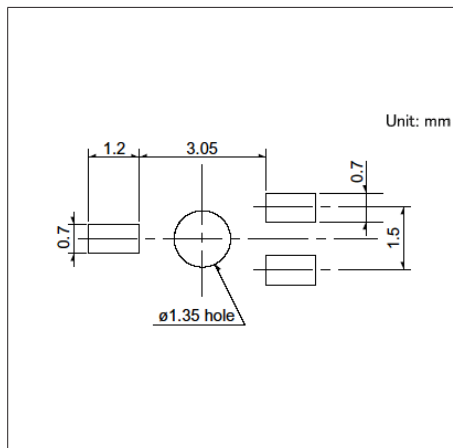

■ Circuit Diagram

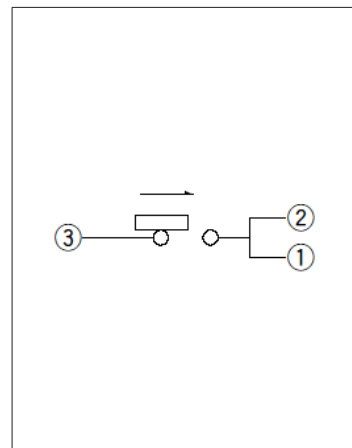

Viewed from direction A in the dimensions.

**Drawing No.8**

■ Dimensions

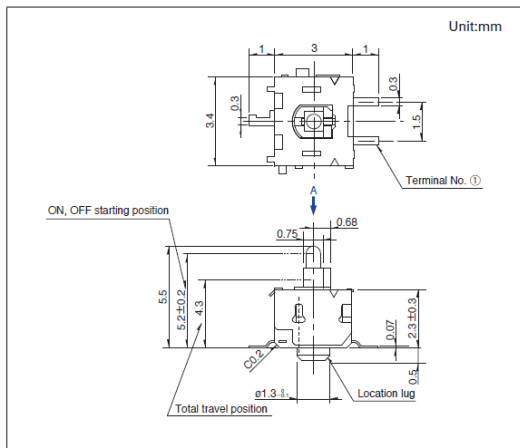

■ Land Dimensions

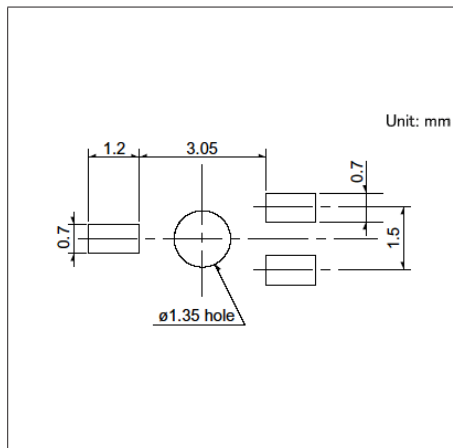

■ Circuit Diagram

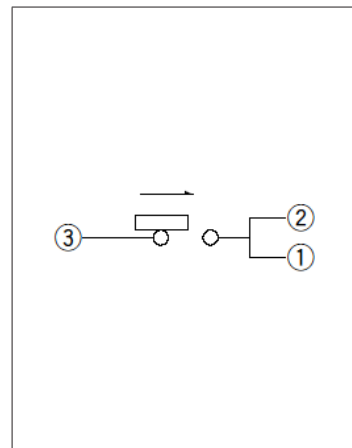

Viewed from direction A in the dimensions.

**Drawing No.9**

■ Dimensions

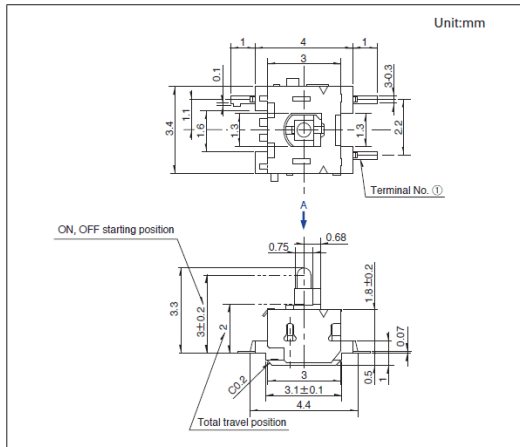

■ Land Dimensions

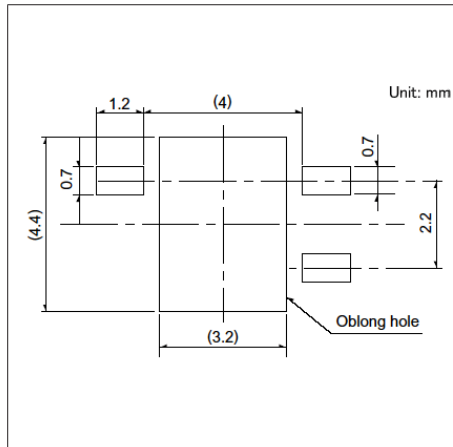

■ Circuit Diagram

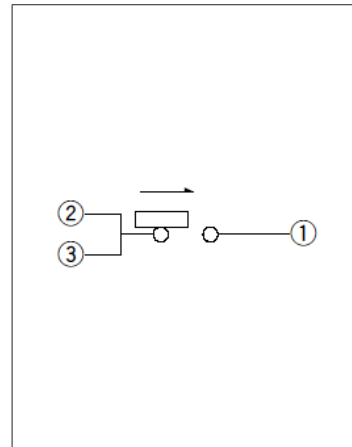

Viewed from direction A in the dimensions.

Switches **Detector Switches**

Compact Two-way, Two-step Detection  
**SSCQ Series**

Two-stage detection type, 30% smaller than conventional products, among the smallest in the industry.

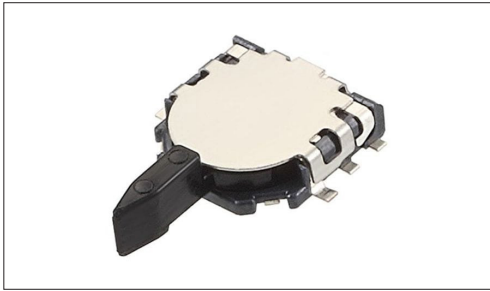

- Rating(max.)/(min.)(Resistive load): 1mA 5V DC/50μA 3V DC
- Contact resistance(Initial/After operating life): 2Ω max./5Ω max.
- Operating life without load: 50,000 cycles
- Operating life with load Rating(max.)(Resistive load):  
50,000 cycles 5Ω max.

Applications: Audio\_TV: Cameras

■ Product List

Products No.	Poles	Positions	Operating force	Total travel position	Location lug	Dimensions (W×D×H) (mm)	Water-proof	Dust-proof	Automotive	Drawing No.
<b>SSCQ110100</b>	1	Two-direction, 2-positions each side	0.35N max.	3.73	With	3.8×3.6×0.9	—	—	—	1
<b>SSCQ120102</b>	1	Two-direction, 2-positions each side	0.35N max.	3.73	Without	3.8×3.6×0.9	—	—	—	2

**⚠ Note**

1. This catalog shows only outline specifications. When using the products, please obtain formal specifications for supply.
2. Please place purchase orders for taping products per minimum order unit (1 reel or a case).
3. For the Terminal Layout, please check our website.

■ Packing Specifications

Taping

Number of packages (pcs.)			Tape width (mm)	Export package measurements (mm)
1 reel	1 case / Japan	1 case / export packing		
4,000	8,000	16,000	16	417 x 409 x 139

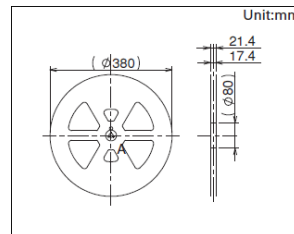

**Drawing No.1**

■ Dimensions

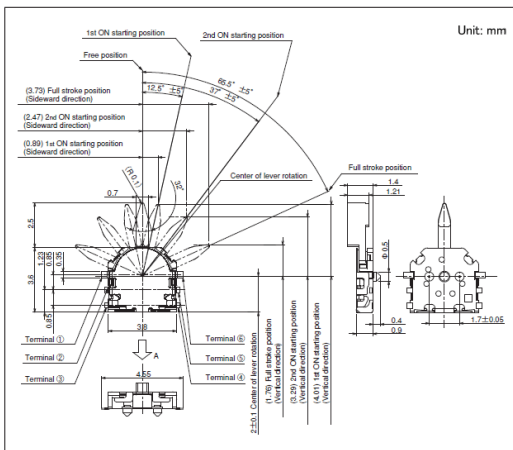

■ Land Dimensions

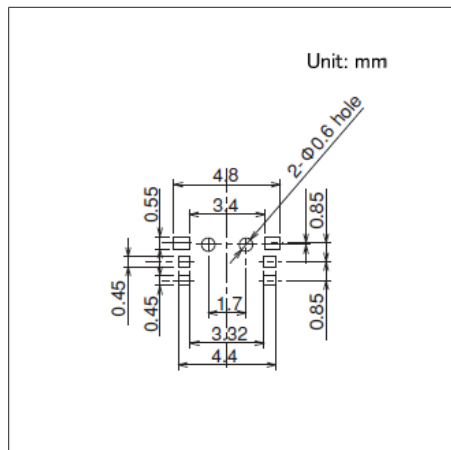

■ Circuit Diagram

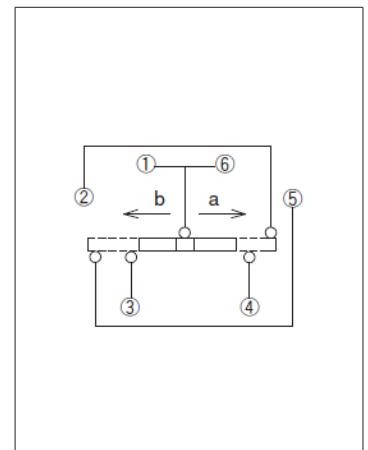



Switches **Detector Switches**

Compact Two-way Detection  
**SSCM Series**

Thin-profile type with a body height of 1.5mm, capable of detecting two lateral directions.



- Rating(max.)/(min.)(Resistive load): 1mA 5V DC/50μA 3V DC
- Contact resistance(Initial/After operating life): 2Ω max./5Ω max.
- Operating life without load: 50,000 cycles
- Operating life with load Rating(max.)(Resistive load):  
50,000 cycles 5Ω max.

Applications: Mobile: Smartphones, tablets, Headsets, wearables,  
Notebooks, peripherals  
Game: Home handheld consoles, Virtual/augmented reality  
Healthcare: Healthcare equipment  
Audio\_TV: Audio, Cameras

■ Product List

Products No.	Poles	Positions	Operating force	Terminal type	Total travel position	Location lug	Dimensions (W×D×H) (mm)	Water-proof	Dust-proof	Automotive	Drawing No.
<b>SSCM110100</b>	1	2	0.35N max.	For PC board (Reflow)	1.57	With	4.0×5.0×1.5	—	—	—	1
<b>SSCM120100</b>	1	2	0.35N max.	For PC board (Reflow)	1.57	Without	4.0×5.0×1.5	—	—	—	2

**Note**

1. This catalog shows only outline specifications. When using the products, please obtain formal specifications for supply.
2. Please place purchase orders for taping products per minimum order unit (1 reel or a case).
3. For the Terminal Layout, please check our website.

■ Packing Specifications

Taping

Number of packages (pcs.)			Tape width (mm)	Export package measurements (mm)
1 reel	1 case / Japan	1 case / export packing		
3,000	6,000	12,000	16	417 x 409 x 139

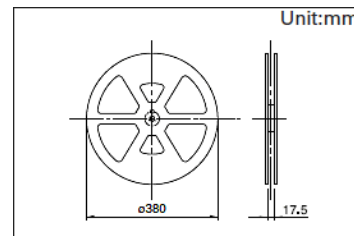

**Drawing No.1**

■ Dimensions

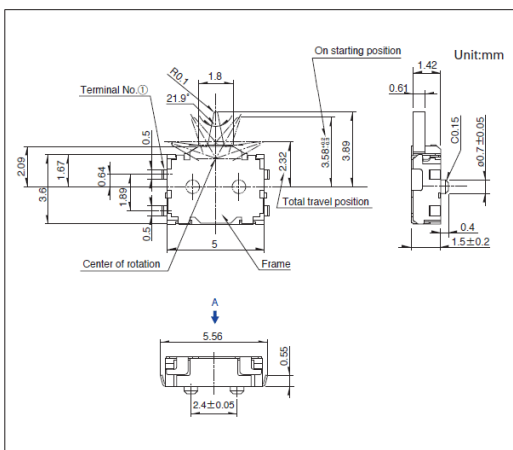

■ Land Dimensions

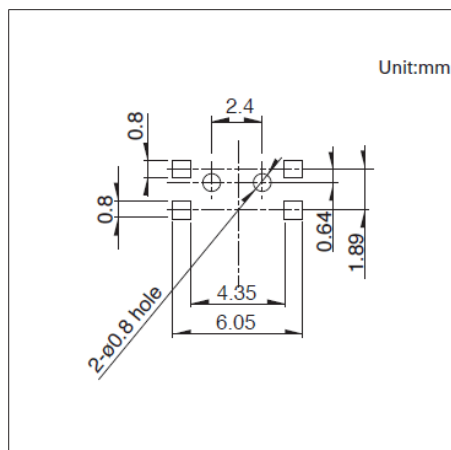

■ Circuit Diagram

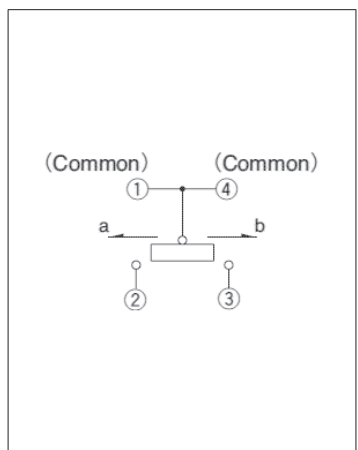

Viewed from direction A in the dimensions.

Compact Two-way Detection  
**SSCM Series**

**Drawing No.2**

■ Dimensions

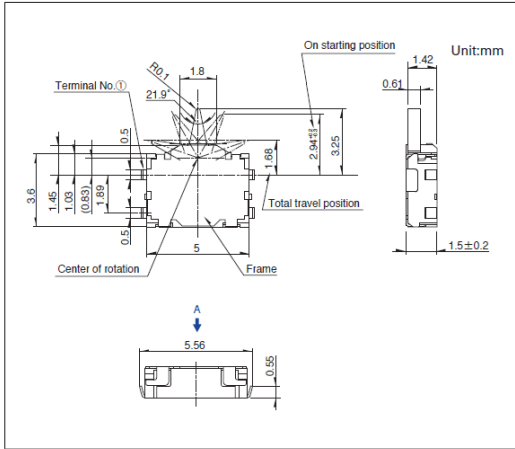

■ Land Dimensions

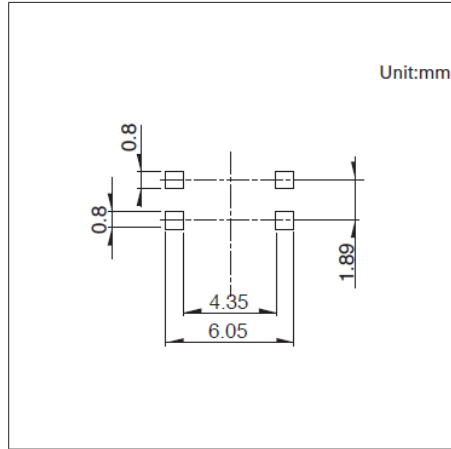

■ Circuit Diagram

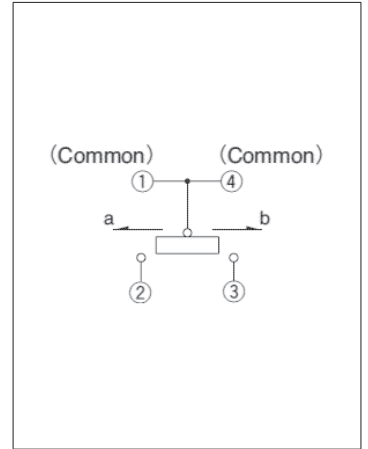

Viewed from direction A in the dimensions.

Low-profile Tri-directional Operation

**SPVL Series**

Thin-profile type with a body height of 1.0mm, offering 180° flexible operation.

 Automotive

- Rating(max.)/(min.)(Resistive load): 1mA 5V DC/50 $\mu$ A 3V DC
- Contact resistance(Initial/After operating life): 2 $\Omega$  max./5 $\Omega$  max.
- Operating life without load: 50,000 cycles
- Operating life with load Rating(max.)(Resistive load):  
50,000 cycles 5 $\Omega$  max.

Applications: Mobile: Smartphones, tablets, Notebooks, peripherals  
 Healthcare: Healthcare equipment  
 Audio\_TV: Cameras  
 Automotive: Navigation/audio systems, HVAC

## ■ Product List

Products No.	Poles	Positions	Operating force	Terminal type	Location lug	Dimensions (W×D×H) (mm)	Water-proof	Dust-proof	Automotive	Drawing No.
SPVL110102	1	1	0.35N max.	For PC board (Reflow)	With	6.6×5.55×1.0	—	—	●	1
SPVL120101	1	1	0.35N max.	For PC board (Reflow)	Without	6.6×5.55×1.0	—	—	●	2

 Note

1. This catalog shows only outline specifications. When using the products, please obtain formal specifications for supply.
2. Please place purchase orders per minimum order unit (integer).
3. This products can be used in vehicles.  
Although these products are designed to perform over a wide operating temperature range, please ensure that you receive and read the formal delivery specifications before use.
4. For the Terminal Layout, please check our website.

## ■ Packing Specifications

Taping

Number of packages (pcs.)			Tape width (mm)	Export package measurements (mm)
1 reel	1 case / Japan	1 case / export packing		
5,000	10,000	20,000	16	417 x 409 x 139

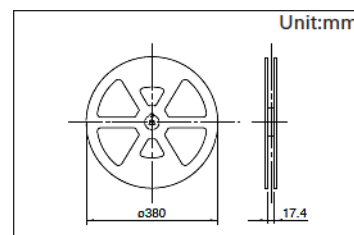



# Switches Detector Switches

## General-purpose Type SPPB Series

Wide product variety supporting various digital devices.

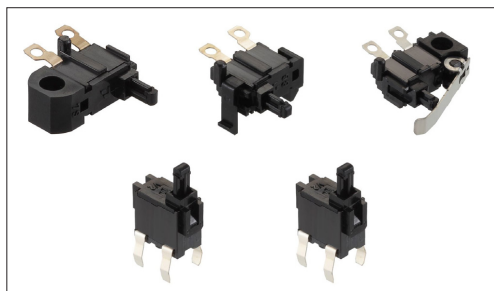

Automotive

- Rating(max.)/(min.)(Resistive load):0.1 A 30V DC/50 $\mu$ A 3V DC
- Contact resistance(Initial/After operating life): 1 $\Omega$  max./2 $\Omega$  max.
- Operating life without load:50,000 cycles
- Operating life with load Rating(max.)(Resistive load):  
50,000 cycles 2 $\Omega$  max.

Applications:Healthcare:Healthcare equipment  
Home:Major home appliances  
Audio\_TV:Audio  
Automotive:Navigation/audio systems, HVAC

### Product List

Products No.	Poles	Positions	Operating force	Operation part shape	Terminal type	Dimensions (W×D×H) (mm)	Water-proof	Dust-proof	Automotive	Drawing No.
SPPB110300	1	1	0.35N max.	Push	For Lead	9.7×3.75×5.1	—	—	●	1
SPPB120200	1	1	0.35N max.	Push	For Lead	9.7×3.75×5.1	—	—	●	2
SPPB310400	1	1	0.35N max.	Push	For Lead	8.8×3.5×5.1	—	—	●	3
SPPB320100	1	1	0.35N max.	Push	For Lead	8.8×3.5×5.1	—	—	●	4
SPPB1A0100	1	1	0.35N max.	Actuator A	For Lead	9.75×3.75×5.7	—	—	●	5
SPPB1A0101	1	1	0.35N max.	Actuator A	For Lead	9.75×3.75×5.7	—	—	●	6
SPPB2A0100	1	1	0.35N max.	Actuator C	For Lead	9.75×3.75×5.7	—	—	●	7
SPPB2A0101	1	1	0.35N max.	Actuator C	For Lead	9.75×3.75×5.7	—	—	●	8
SPPB512300	1	1	0.35N max.	Push	For PC board (Dip)	6.3×3.0×4.9	—	—	●	9
SPPB610400	1	1	0.35N max.	Push	For PC board (Dip)	6.3×5.1×3.7	—	—	●	10
SPPB620300	1	1	0.35N max.	Push	For PC board (Dip)	6.3×5.1×3.7	—	—	●	11
SPPB5A0100	1	1	0.35N max.	Actuator A	For PC board (Dip)	9.15×3.75×5.5	—	—	●	12
SPPB6A0100	1	1	0.35N max.	Actuator A	For PC board (Dip)	10.0×6.1×5.25	—	—	●	13
SPPB6A0400	1	1	0.35N max.	Actuator A	For PC board (Dip)	10.0×6.1×5.25	—	—	●	14
SPPB530701	1	1	0.35N max.	Push	For PC board (Reflow)	6.5×3.1×4.9	—	—	●	15
SPPB530601	1	1	0.35N max.	Push	For PC board (Reflow)	6.4×3.0×4.9	—	—	●	16
SPPB630101	1	1	0.35N max.	Push	For PC board (Reflow)	6.3×6.1×4.25	—	—	●	17
SPPB640201	1	1	0.35N max.	Push	For PC board (Reflow)	6.3×6.1×4.25	—	—	●	18

### Note

1. This catalog shows only outline specifications. When using the products, please obtain formal specifications for supply.
2. Please place purchase orders per minimum order unit (integer).
3. Please place purchase orders for taping products per minimum order unit (1 reel or a case).
4. This products can be used in vehicles.

Although these products are designed to perform over a wide operating temperature range, please ensure that you receive and read the formal delivery specifications before use.

General-purpose Type  
**SPPB Series**

■ Packing Specifications

Bulk

Products No.	Number of packages(pcs.)		Export package measurements (mm)
	1 case / Japan	1 case / export packing	
SPPB110300 SPPB120200 SPPB310400 SPPB320100 SPPB610400 SPPB620300	2,000	10,000	400 x 270 x 290
SPPB1A0100 SPPB1A0101 SPPB2A0100 SPPB2A0101 SPPB5A0100 SPPB6A0100 SPPB6A0400	1,000	5,000	400 x 270 x 290
SPPB512300	4,000	20,000	400 x 270 x 290

Taping

Products No.	Number of packages(pcs.)			Tape width (mm)	Export package measurements (mm)
	1 reel	1 case / Japan	1 case / export packing		
SPPB530701	1,500	3,000	6,000	24	406×406×160
SPPB530601	600	1,200	2,400	24	406×406×160
SPPB630101 SPPB640201	1,300	2,600	5,200	24	406×406×160

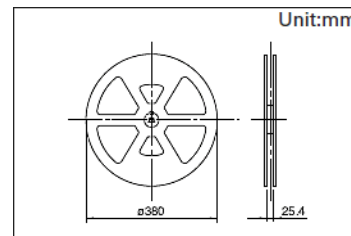

**Drawing No.1**

■ Dimensions

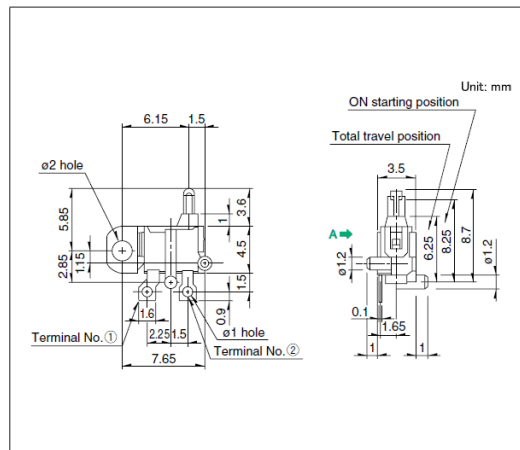

■ Mounting Hole Dimensions

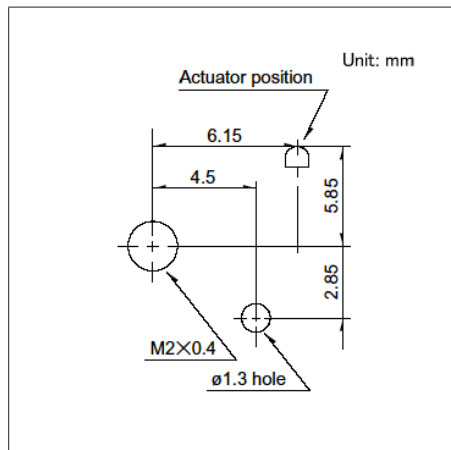

■ Circuit Diagram

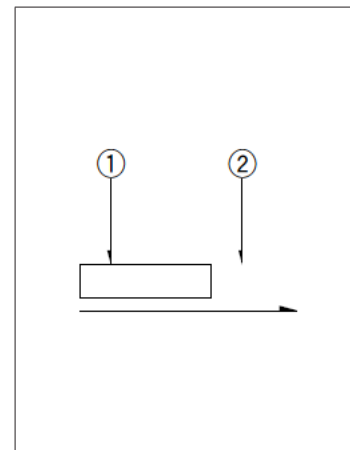

Viewed from direction A in the dimensions.

General-purpose Type  
SPPB Series

Drawing No.2

■ Dimensions

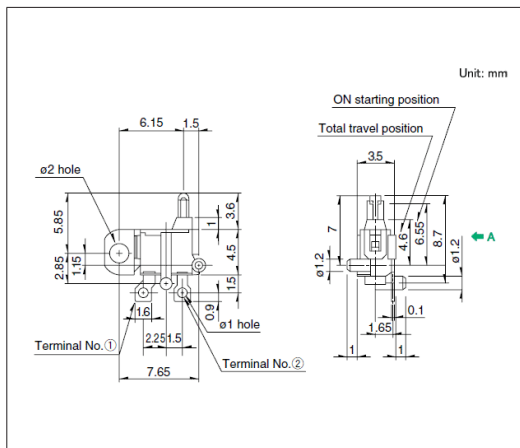

■ Mounting Hole Dimensions

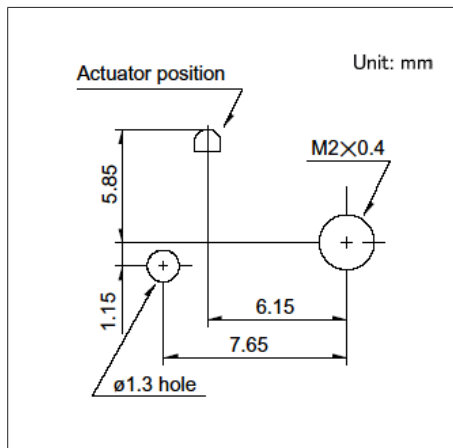

■ Circuit Diagram

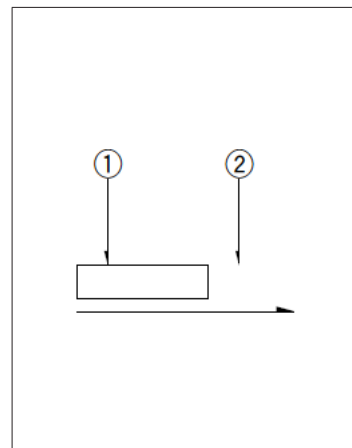

Viewed from direction A in the dimensions.

Drawing No.3

■ Dimensions

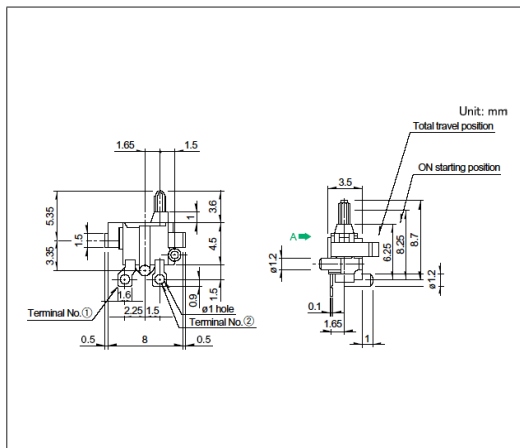

■ Mounting Hole Dimensions

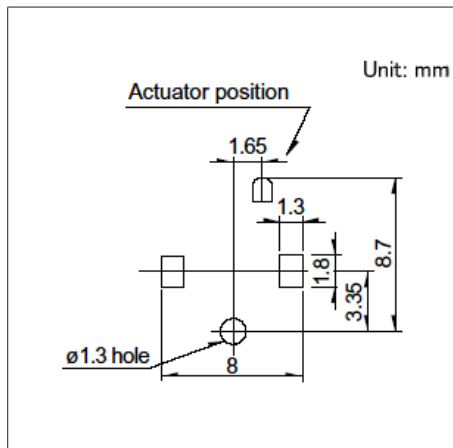

■ Circuit Diagram

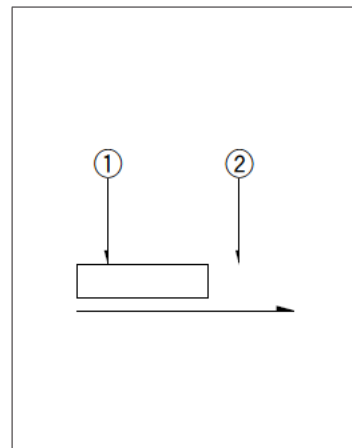

Viewed from direction A in the dimensions.

Drawing No.4

■ Dimensions

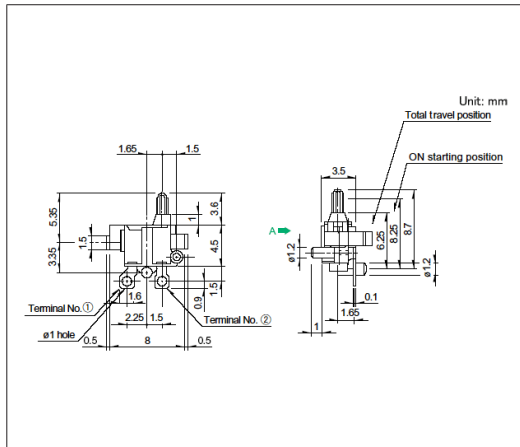

■ Mounting Hole Dimensions

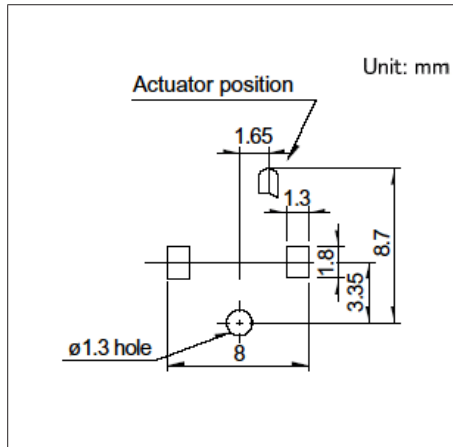

■ Circuit Diagram

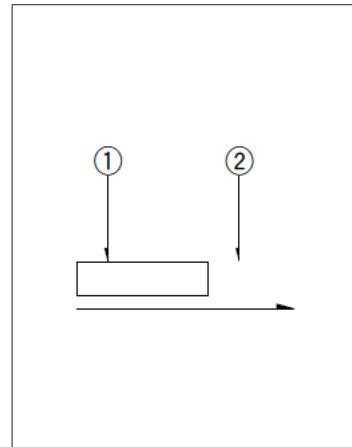

Viewed from direction A in the dimensions.

General-purpose Type  
SPPB Series

Drawing No.5

■ Dimensions

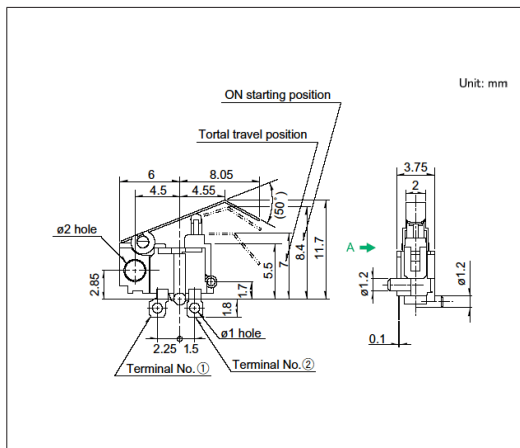

■ Mounting Hole Dimensions

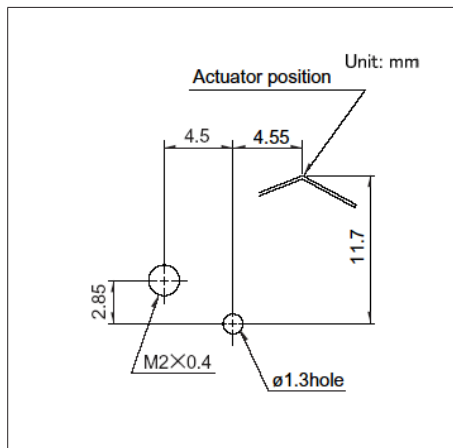

■ Circuit Diagram

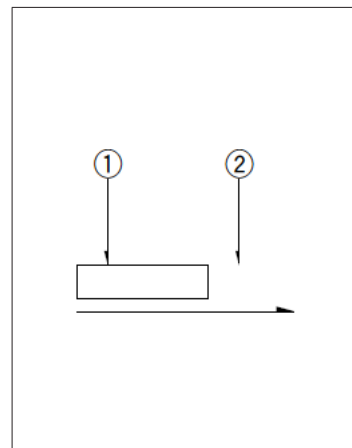

Viewed from direction A in the dimensions.

Drawing No.6

■ Dimensions

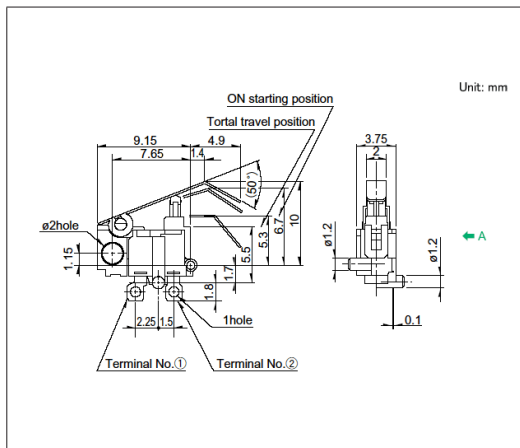

■ Mounting Hole Dimensions

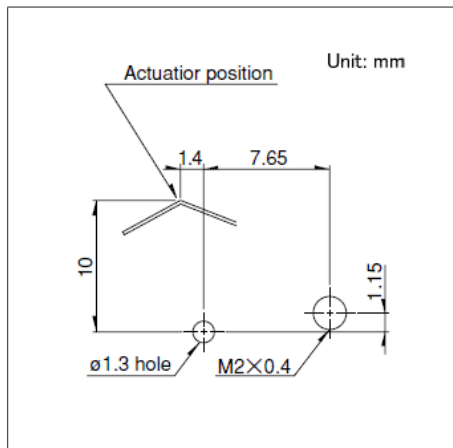

■ Circuit Diagram

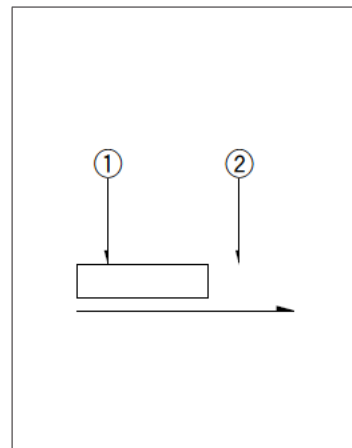

Viewed from direction A in the dimensions.

Drawing No.7

■ Dimensions

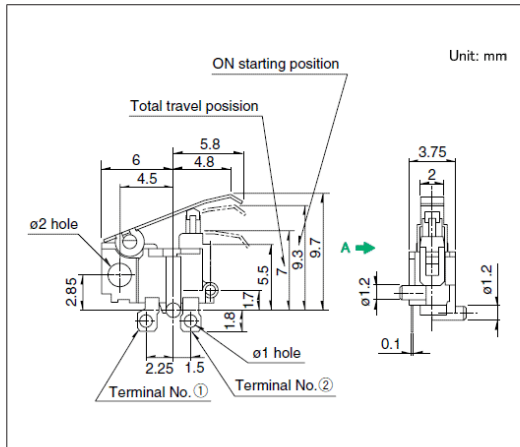

■ Mounting Hole Dimensions

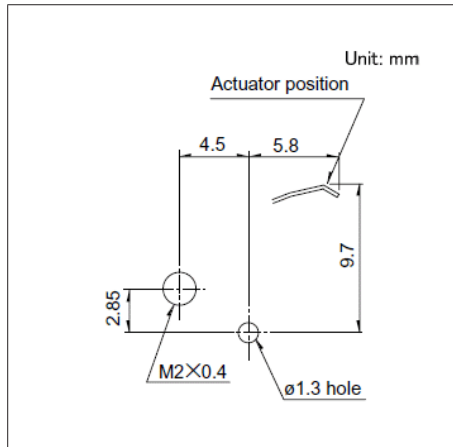

■ Circuit Diagram

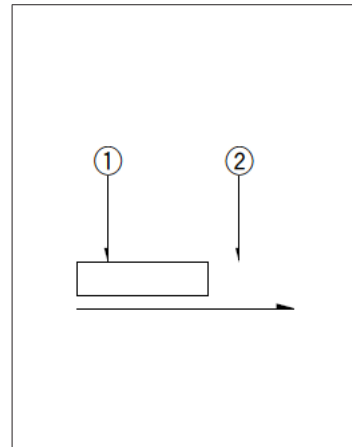

Viewed from direction A in the dimensions.

General-purpose Type  
**SPPB Series**

**Drawing No.8**

■ Dimensions

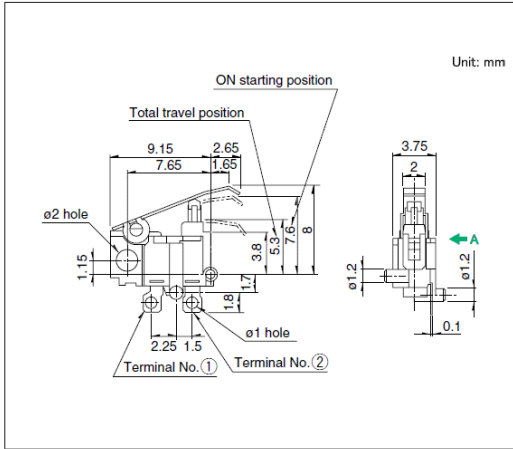

■ Mounting Hole Dimensions

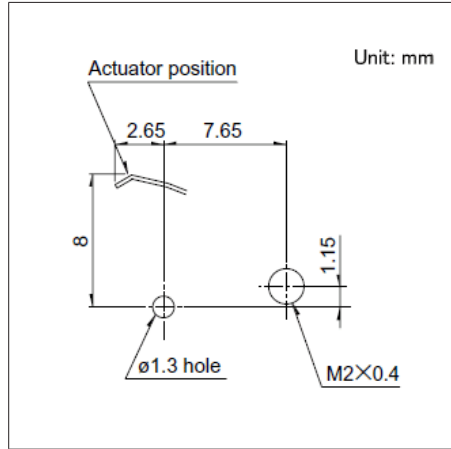

■ Circuit Diagram

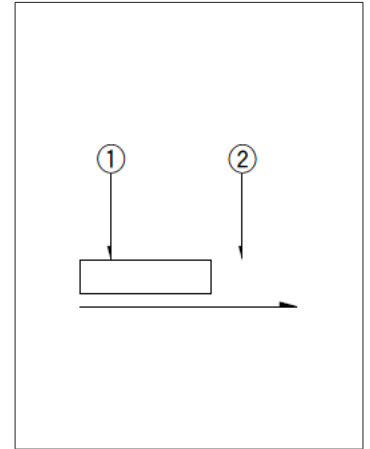

Viewed from direction A in the dimensions.

**Drawing No.9**

■ Dimensions

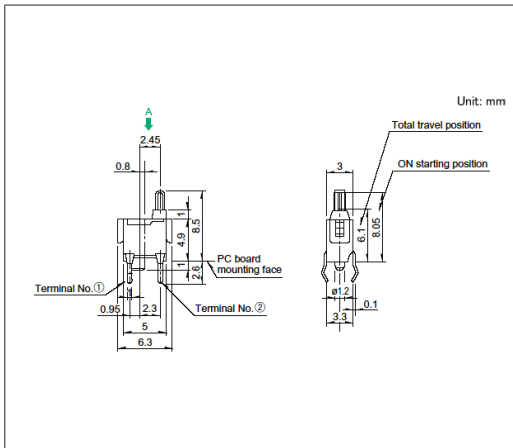

■ Mounting Hole Dimensions

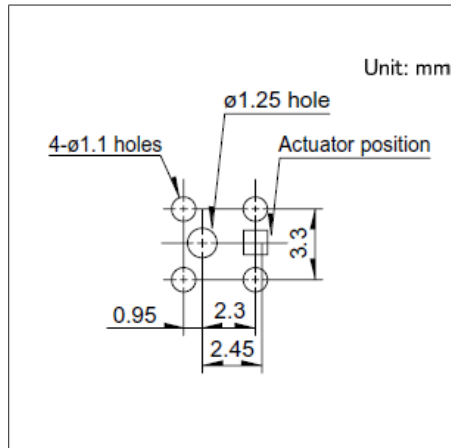

■ Circuit Diagram

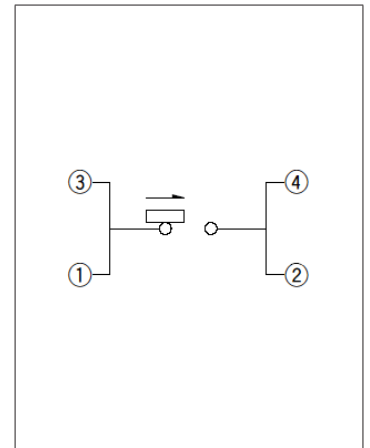

Viewed from direction A in the dimensions.

**Drawing No.10**

■ Dimensions

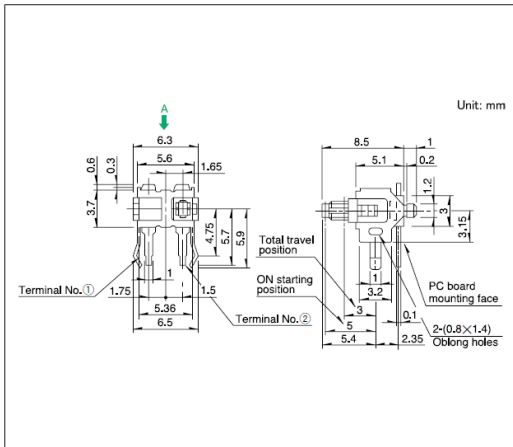

■ Mounting Hole Dimensions

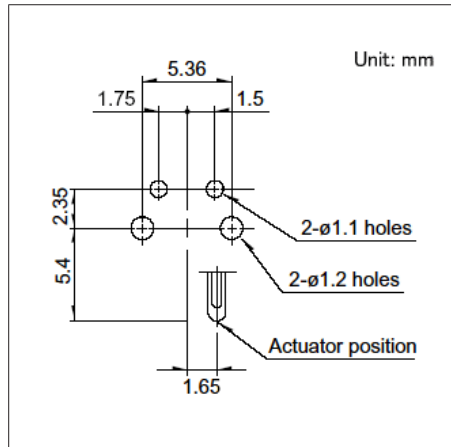

■ Circuit Diagram

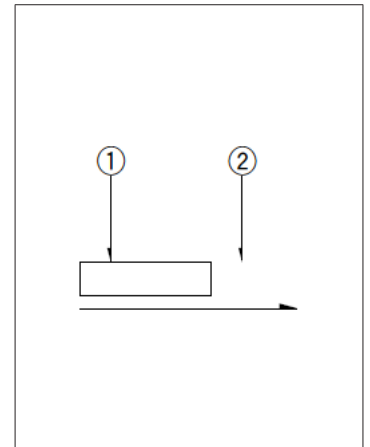

Viewed from direction A in the dimensions.

General-purpose Type  
SPPB Series

Drawing No.11

■ Dimensions

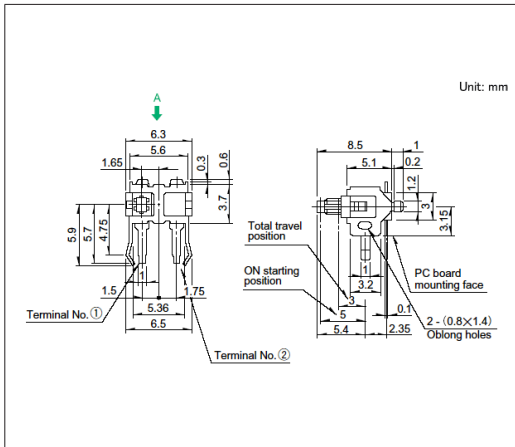

■ Mounting Hole Dimensions

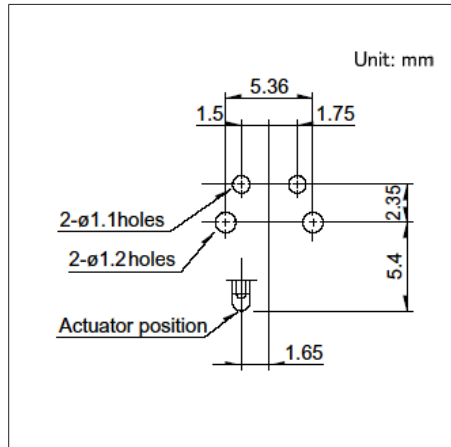

■ Circuit Diagram

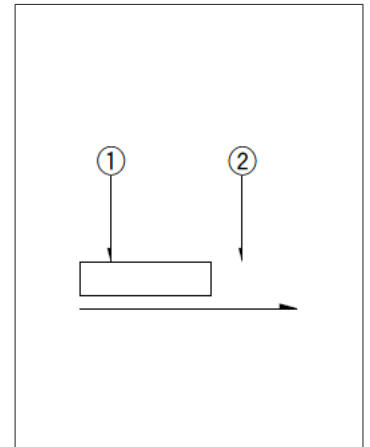

Viewed from direction A in the dimensions.

Drawing No.12

■ Dimensions

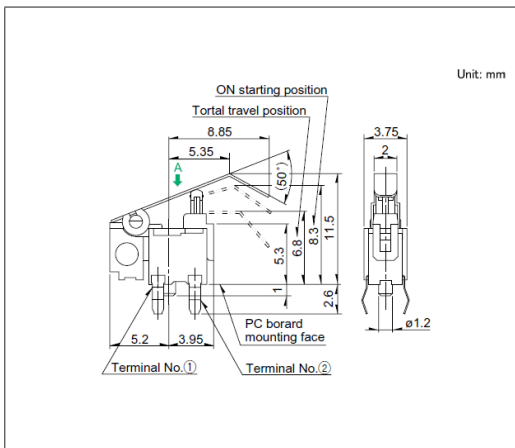

■ Mounting Hole Dimensions

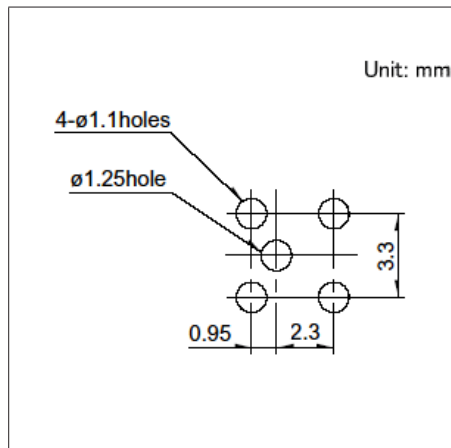

■ Circuit Diagram

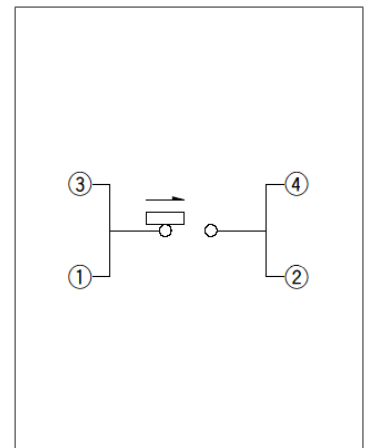

Viewed from direction A in the dimensions.

Drawing No.13

■ Dimensions

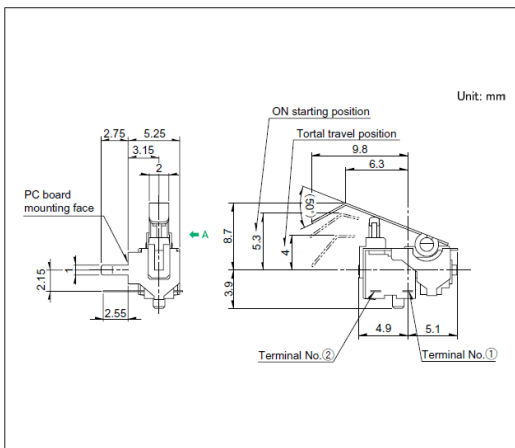

■ Mounting Hole Dimensions

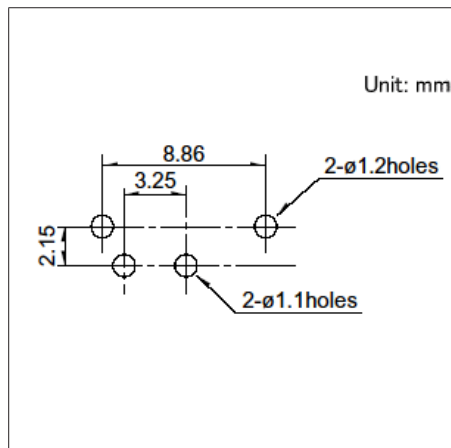

■ Circuit Diagram

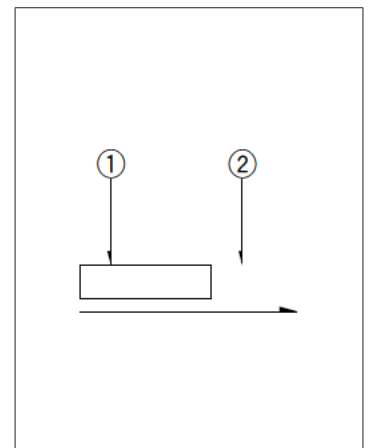

Viewed from direction A in the dimensions.

Drawing No.14

■ Dimensions

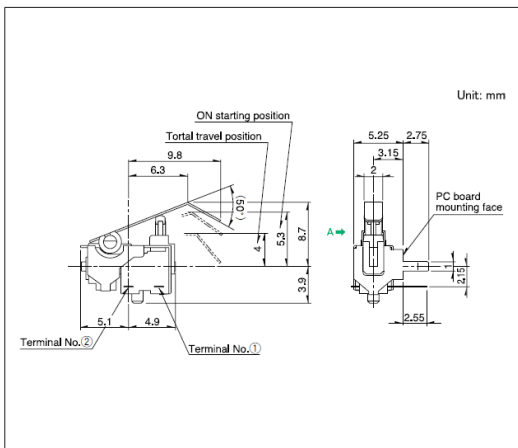

■ Mounting Hole Dimensions

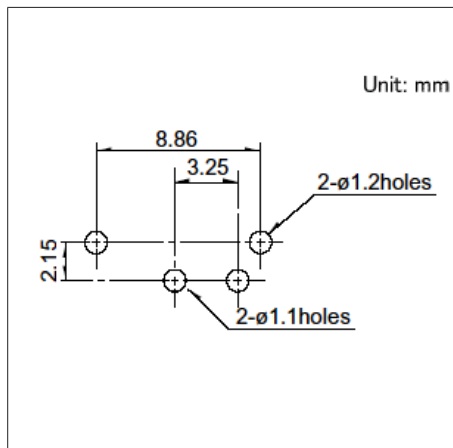

■ Circuit Diagram

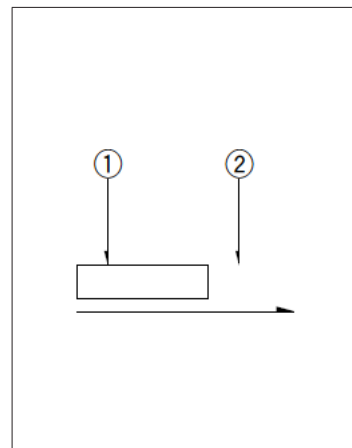

Viewed from direction A in the dimensions.

Drawing No.15

■ Dimensions

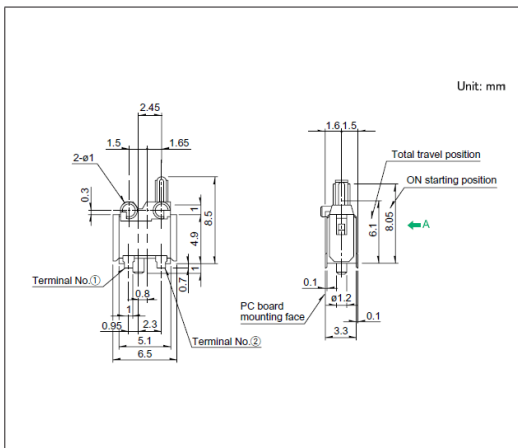

■ Land Dimensions

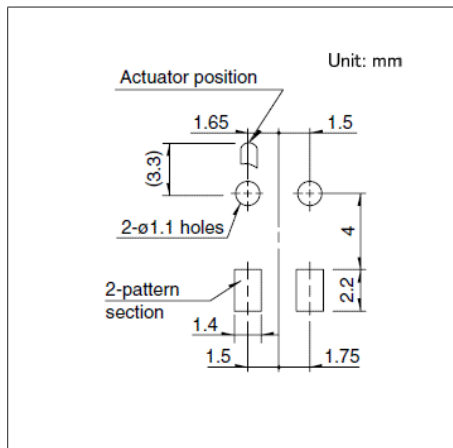

■ Circuit Diagram

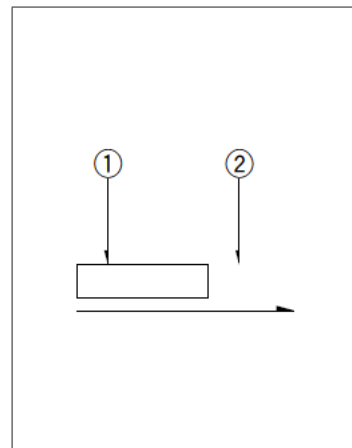

Viewed from direction A in the dimensions.

Drawing No.16

■ Dimensions

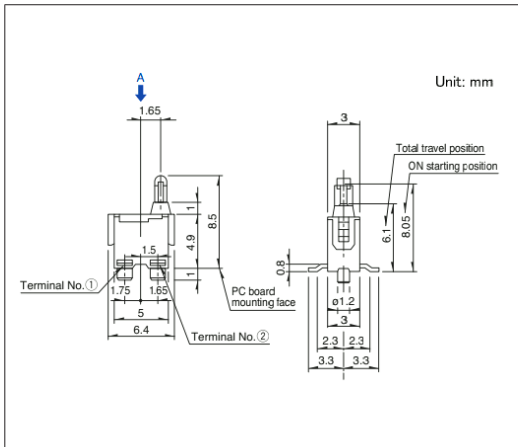

■ Land Dimensions

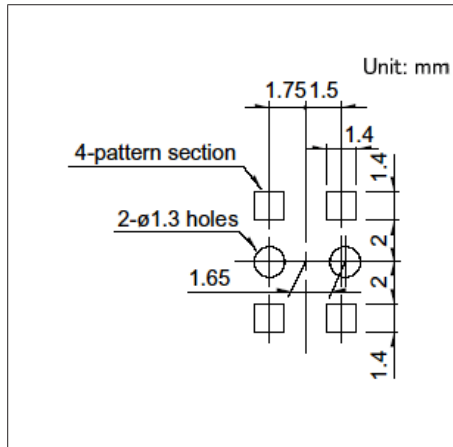

■ Circuit Diagram

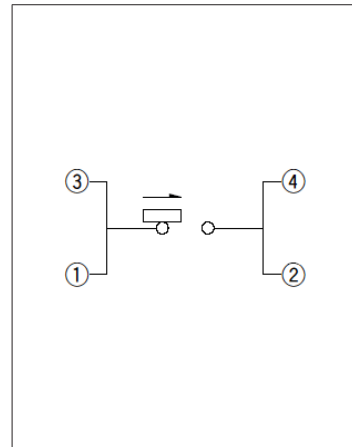

Viewed from direction A in the dimensions.

General-purpose Type  
SPPB Series

Drawing No.17

■ Dimensions

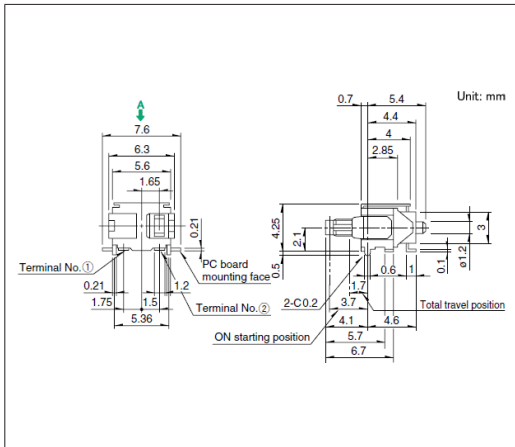

■ Land Dimensions

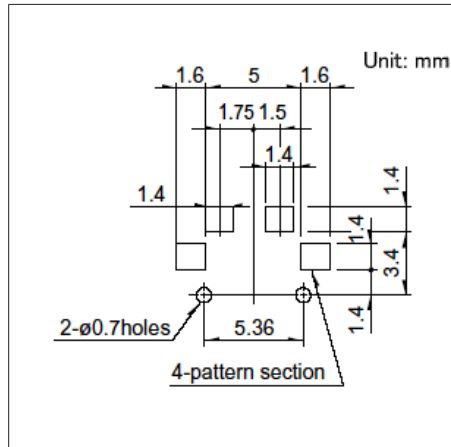

■ Circuit Diagram

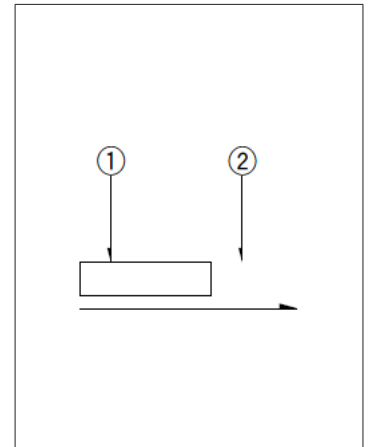

Viewed from direction A in the dimensions.

Drawing No.18

■ Dimensions

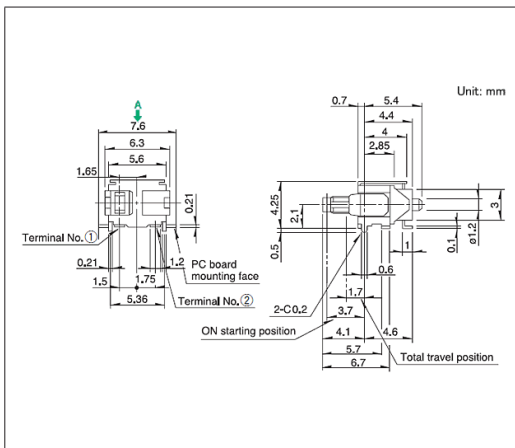

■ Land Dimensions

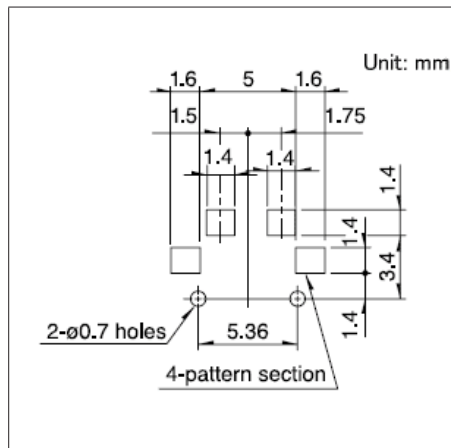

■ Circuit Diagram

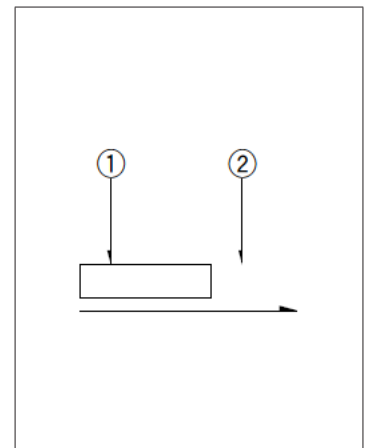

Viewed from direction A in the dimensions.

Switches **Detector Switches**

Micro Switch Type  
**SSCT Series**

Micro switch type with printable or lead wiring, mountable on panels with screws.

Automotive

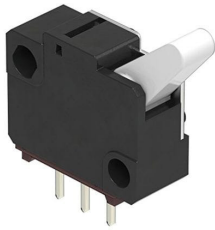

- Rating(max.)/(min.)(Resistive load):0.1A 12V DC/50μA 3V DC
- Contact resistance(Initial/After operating life):200mΩ max./500mΩ max.
- Operating life without load:10,000 cycles
- Operating life with load Rating(max.)(Resistive load):  
10,000 cycles 500mΩ max.

Applications:Automotive:Hood Latch (Side/Rear/Door/Gear)

■ Product List

Products No.	Poles	Positions	Operating force	Changeover timing	Operation part shape	Terminal type	Dimensions (W×D×H) (mm)	Water-proof	Dust-proof	Automotive	Drawing No.
SSCTL10600	1	2	0.7±0.3N	Non shorting	Lever	For PC board	12.5×5.0×11.5	—	—	●	1
SSCTL10400	1	2	0.7±0.3N	Non shorting	Lever	For Lead	12.5×5.0×11.5	—	—	●	2

Note

1. This catalog shows only outline specifications. When using the products, please obtain formal specifications for supply.
2. Please place purchase orders per minimum order unit (integer).
3. This products can be used in vehicles.  
Although these products are designed to perform over a wide operating temperature range, please ensure that you receive and read the formal delivery specifications before use.
4. For the Timing Lag Diagram and Terminal Style, please check our website.

■ Packing Specifications

Bulk

Number of packages (pcs.)		Export package measurements (mm)
1 case / Japan	1 case / export packing	
1,000	5,000	400 x 270 x 290

Drawing No.1

■ Dimensions

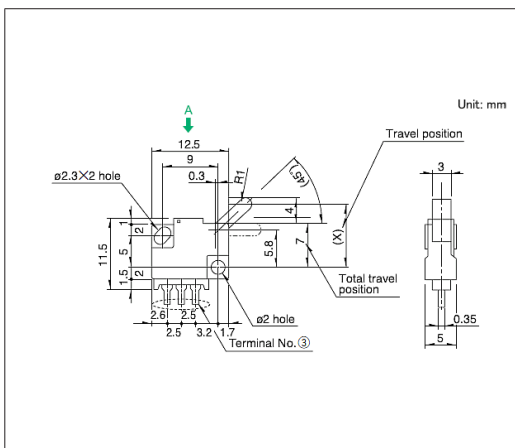

■ Mounting Hole Dimensions

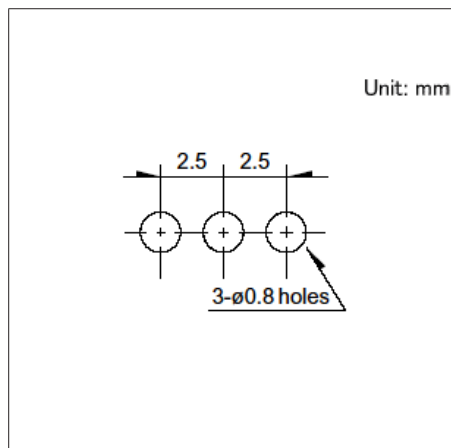

■ Circuit Diagram

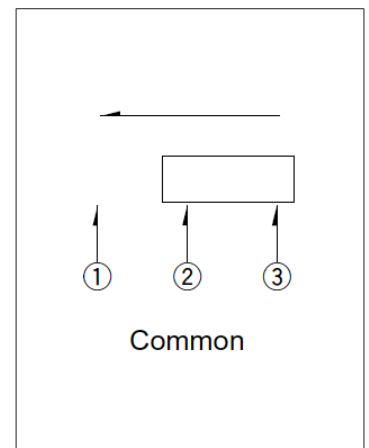

Viewed from direction A in the dimensions.

Micro Switch Type  
**SSCT Series**

**Drawing No.2**

■ Dimensions

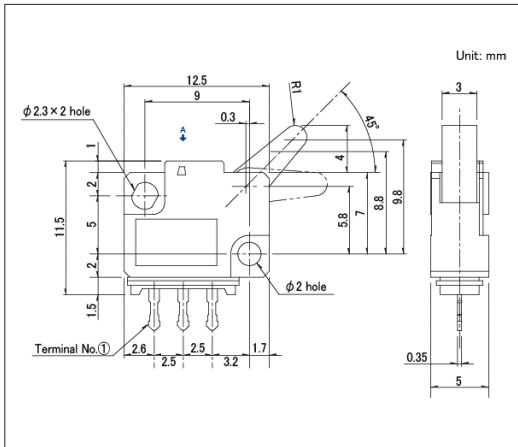

■ Circuit Diagram

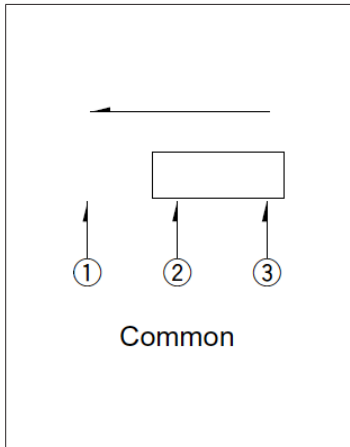

Switches **Detector Switches**

Two-way Detection  
**SSCF Series**

Improved design freedom around set mechanisms with left-right detection capability.

Automotive



- Rating(max.)/(min.)(Resistive load):0.1A 12V DC/50μA 3V DC
- Contact resistance(Initial/After operating life): 100mΩ max./300mΩ max.
- Operating life without load:50,000 cycles
- Operating life with load Rating(max.)(Resistive load):  
50,000 cycles 300mΩ max.

Applications:Audio\_TV:Audio  
Automotive:Hood Latch (Side/Rear/Door/Gear)

■ Product List

Products No.	Poles	Positions	Operating force	Changeover timing	Terminal type	Dimensions (W×D×H) (mm)	Water-proof	Dust-proof	Automotive	Drawing No.
<b>SSCF110100</b>	1	2	0.7N max.	Non shorting	For PC board	11.0×5.8×12.4	—	—	●	1
<b>SSCF210100</b>	1	2	0.7N max.	Non shorting	For PC board	15.5×5.8×12.4	—	—	●	2
<b>SSCF210300</b>	1	2	0.7N max.	Non shorting	For Lead	15.5×5.8×12.4	—	—	●	3
<b>SSCF310100</b>	1	2	0.7N max.	Non shorting	For PC board	11.0×5.8×12.4	—	—	●	4

Note

1. This catalog shows only outline specifications. When using the products, please obtain formal specifications for supply.
2. Please place purchase orders per minimum order unit (integer).
3. This products can be used in vehicles.  
Although these products are designed to perform over a wide operating temperature range, please ensure that you receive and read the formal delivery specifications before use.
4. For the Terminal Style, please check our website.

■ Packing Specifications

Bulk

Number of packages (pcs.)		Export package measurements (mm)
1 case / Japan	1 case / export packing	
600	3,000	400 x 270 x 290

**Drawing No.1**

■ Dimensions

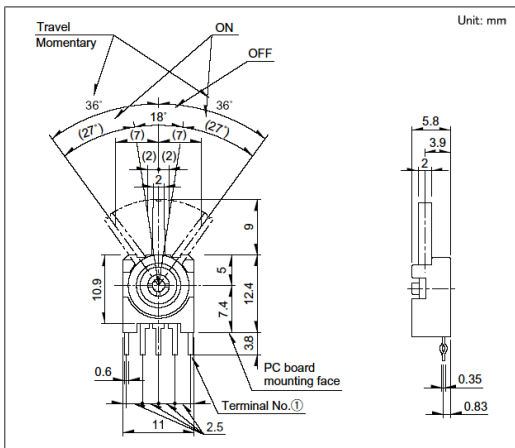

■ Mounting Hole Dimensions

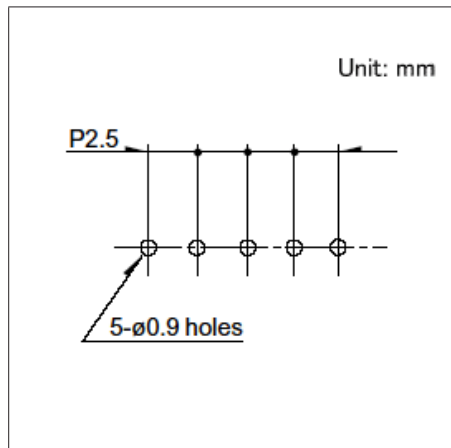

■ Circuit Diagram

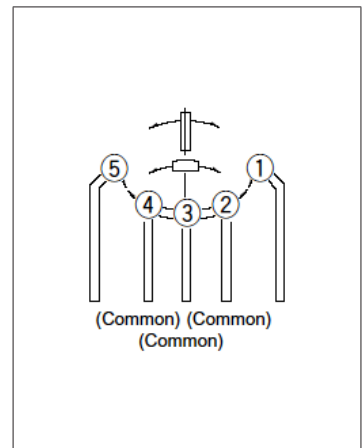

Two-way Detection  
SSCF Series

Drawing No.2

■ Dimensions

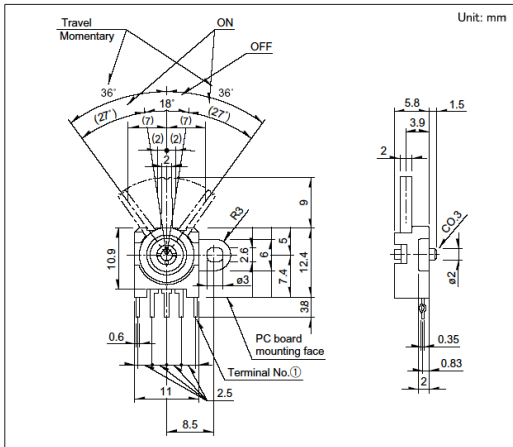

■ Circuit Diagram

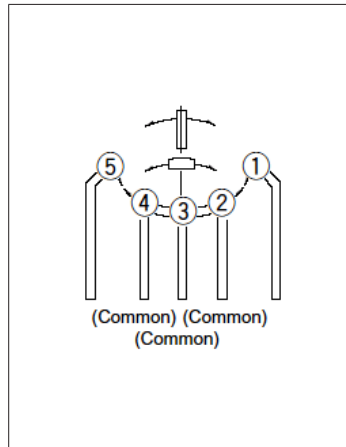

Drawing No.3

■ Dimensions

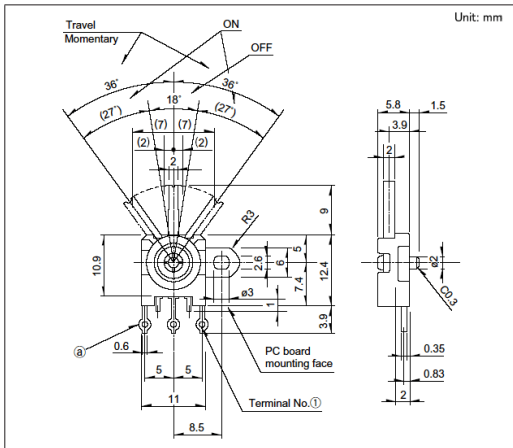

■ Circuit Diagram

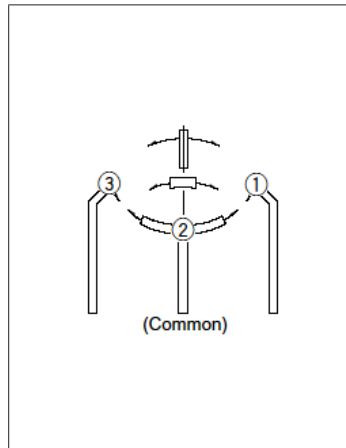

Drawing No.4

■ Dimensions

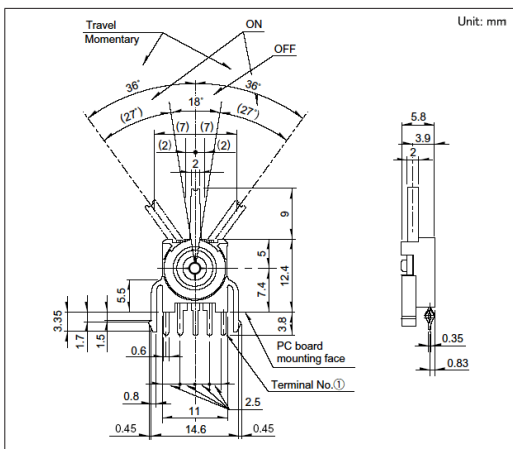

■ Mounting Hole Dimensions

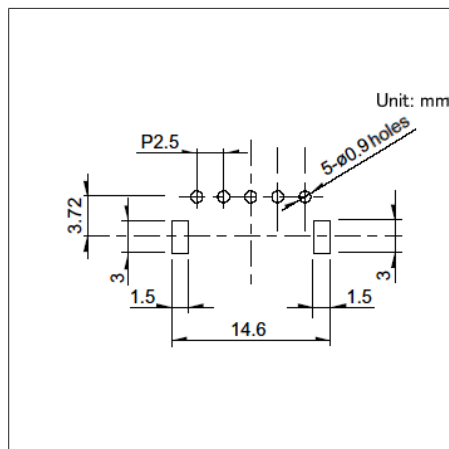

■ Circuit Diagram

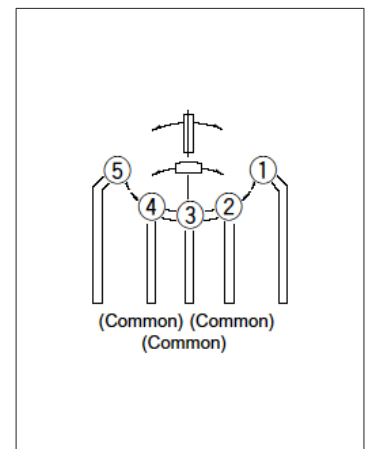

Switches **Detector Switches**

Two-way Operation with Female Connector Terminal  
**SSCW Series**

Single-circuit, single-contact design with connector connection, eliminating soldering.

 Automotive



- Rating(max.)/(min.)(Resistive load):0.1A 12V DC/100μA 3V DC
- Contact resistance(Initial/After operating life):500mΩ max./1Ω max.
- Operating life without load:100,000 cycles
- Operating life with load Rating(max.)(Resistive load):  
100,000 cycles 1Ω max.

Applications:Energy\_Industrial:Robots, drones,Industrial equipment  
 Home:Major home appliances  
 Automotive:Hood Latch (Side/Rear/Door/Gear)

■ Product List

Products No.	Poles	Positions	Operating force	Terminal type	Dimensions (W×D×H) (mm)	Water-proof	Dust-proof	Automotive	Drawing No.
<b>SSCW110102</b>	1	1	1N max.	Female connector type	5,3×13.1×11.35	—	—	●	1

 Note

1. This catalog shows only outline specifications. When using the products, please obtain formal specifications for supply.
2. Please place purchase orders per minimum order unit (integer).
3. This products can be used in vehicles.

Although these products are designed to perform over a wide operating temperature range, please ensure that you receive and read the formal delivery specifications before use.

■ Packing Specifications

Bulk

Number of packages (pcs.)		Export package measurements (mm)
1 case / Japan	1 case / export packing	
2,000	10,000	389 x 276 x 380

**Drawing No.1**

■ Dimensions

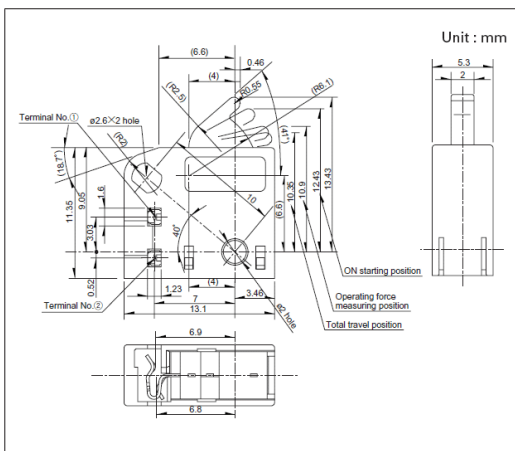

■ Recommended Unit Terminal style

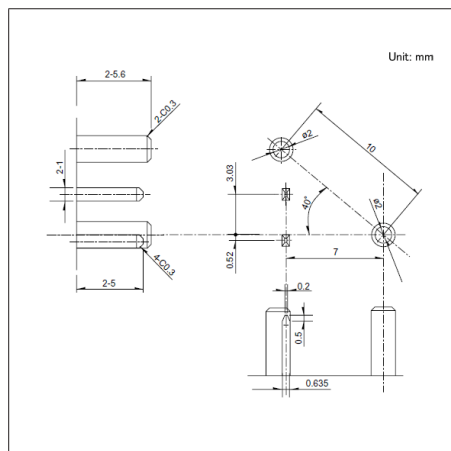

■ Circuit Diagram

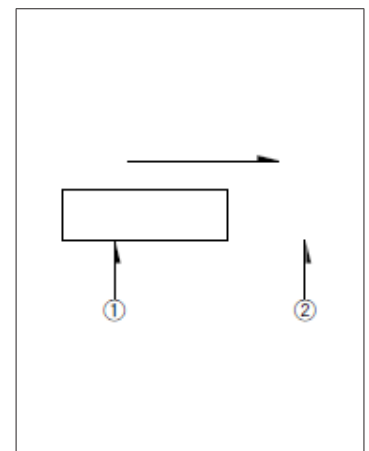

Switches **Detector Switches**

Two-way Detection with Female Connector Terminal  
**SSCL Series**

One-touch connection with female connector terminals, achieving solderless assembly.

Automotive



- Rating(max.)/(min.)(Resistive load):0.1A 12V DC/50μA 5V DC
- Contact resistance(Initial/After operating life):500mΩ max./1Ω max.
- Operating life without load:50,000 cycles
- Operating life with load Rating(max.)(Resistive load):  
50,000 cycles 1Ω max.

Applications:Automotive:Hood Latch (Side/Rear/Door/Gear)

■ Product List

Products No.	Poles	Positions	Operating force	Terminal type	Dimensions (W×D×H) (mm)	Water-proof	Dust-proof	Automotive	Drawing No.
<b>SSCL110101</b>	1	2	0.7N max.	Female connector type	5.3×11.0×16.1	—	—	●	1

Note

1. This catalog shows only outline specifications. When using the products, please obtain formal specifications for supply.
2. Please place purchase orders per minimum order unit (integer).
3. This products can be used in vehicles.  
Although these products are designed to perform over a wide operating temperature range, please ensure that you receive and read the formal delivery specifications before use.

■ Packing Specifications

Bulk

Number of packages(pcs.)		Export package measurements (mm)
1 case / Japan	1 case / export packing	
1,000	5,000	400 x 270 x 290

**Drawing No.1**

■ Dimensions

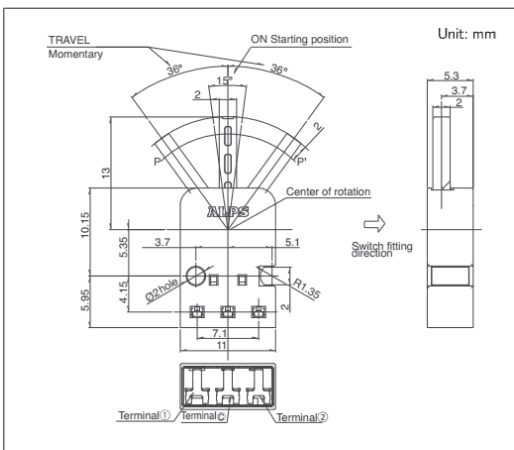

■ Recommended Unit Terminal style

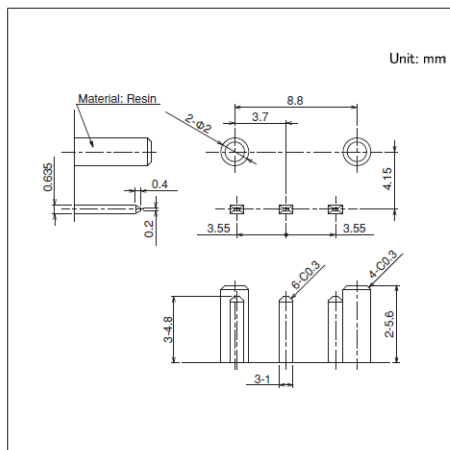

■ Circuit Diagram

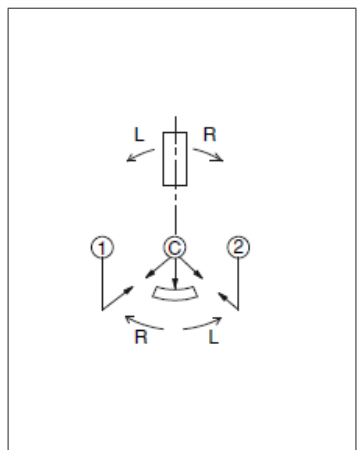

Switches **Detector Switches**

With Connector Terminal Two-way Operation  
**SSCZ Series**

Connector connection eliminates the need for soldering.

Automotive



- Rating(max.)/(min.)(Resistive load):0.1A 16V DC/100μA 3V DC
- Contact resistance(Initial/After operating life):500mΩ max./1Ω max.
- Operating life without load:300,000 cycles
- Operating life with load Rating(max.)(Resistive load):  
300,000 cycles 1Ω max.

Applications:Automotive:Hood Latch (Side/Rear/Door/Gear)

■ Product List

Products No.	Poles	Positions	Operating force	Terminal type	Dimensions (W×D×H) (mm)	Water-proof	Dust-proof	Automotive	Drawing No.
<b>SSCZ110101</b>	1	2	1.1N max.	Connector type	13.84×5.4×15.4	—	—	●	1

Note

1. This catalog shows only outline specifications. When using the products, please obtain formal specifications for supply.
2. Please place purchase orders per minimum order unit (integer).
3. This products can be used in vehicles.  
Although these products are designed to perform over a wide operating temperature range, please ensure that you receive and read the formal delivery specifications before use.

■ Packing Specifications

Bulk

Number of packages(pcs.)		Export package measurements (mm)
1 case / Japan	1 case / export packing	
1,200	6,000	389 x 276 x 380

**Drawing No.1**

■ Dimensions

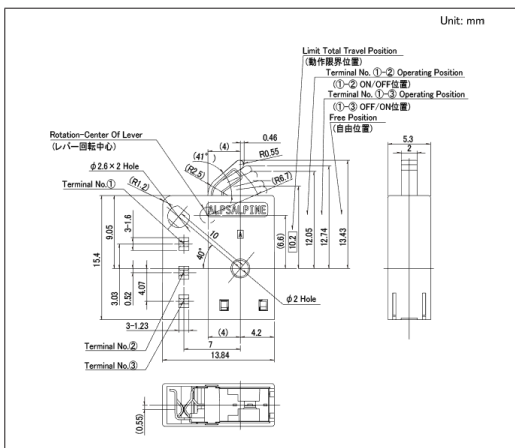

■ Recommended Unit Terminal style

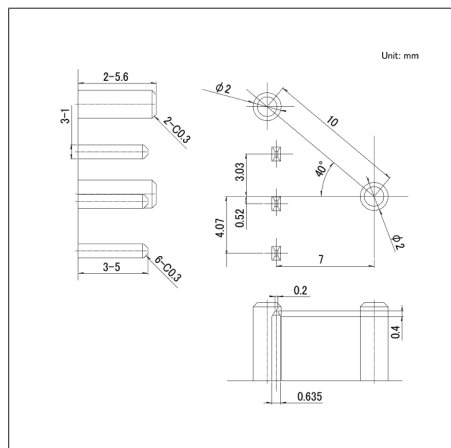

■ Circuit Diagram

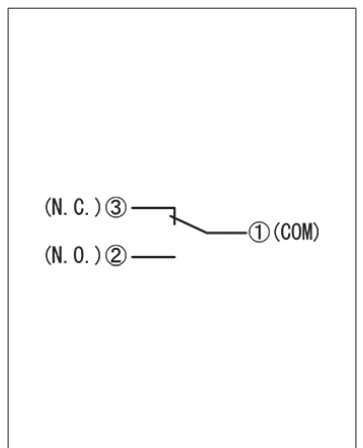

## Water-proof Type SPVQ3 Series

Wide product variety including long-stroke types pressable diagonally without an actuator.

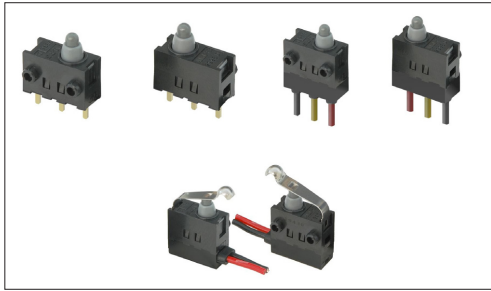

Automotive

Water-proof Type

Dust-proof Type

- Rating(max.)/(min.)(Resistive load):0.1A 12V DC/50μA 5V DC
- Contact resistance(Initial/After operating life):500mΩ max./1Ω max.
- Operating life without load:300,000 cycles
- Operating life with load Rating(max.)(Resistive load):  
300,000 cycles 1Ω max.

Applications:Energy\_Industrial:Robots, drones,Industrial equipment

Home:Major home appliances

Automotive:Hood Latch (Side/Rear/Door/Gear)

### Product List

Products No.	Poles	Positions	Operating force	Changeover timing	Operation part shape	Terminal type	Main body form	Dimensions (W×D×H) (mm)	Water-proof	Dust-proof	Automotive	Drawing No.
SPVQ380400	1	2	1±0.5N	Non shorting	Push	For PC board	Without boss	5.3×13.0×8.35	●	●	●	1
SPVQ380300	1	2	1±0.5N	Non shorting	Push	For PC board	Boss - right side	5.3×13.0×8.35	●	●	●	2
SPVQ380201	1	2	1±0.5N	Non shorting	Push	For PC board	Boss - left side	5.3×13.0×8.35	●	●	●	3
SPVQ380100	1	2	1±0.5N	Non shorting	Push	For PC board	Boss - both sides	5.3×13.0×8.35	●	●	●	4
SPVQ380700	1	2	1±0.5N	Non shorting	Push	For Lead	Boss - right side	5.3×13.0×8.35	●	●	●	5
SPVQ380600	1	2	1±0.5N	Non shorting	Push	For Lead	Boss - left side	5.3×13.0×8.35	●	●	●	6
SPVQ380500	1	2	1±0.5N	Non shorting	Push	For Lead	Boss - both sides	5.3×13.0×8.35	●	●	●	7
SPVQ380900	1	2	1±0.5N	Non shorting	Push	Angle (Right)	Boss - right side	5.3×13.0×8.35	●	●	●	8
SPVQ380800	1	2	1±0.5N	Non shorting	Push	Angle (Left)	Boss - left side	5.3×13.0×8.35	●	●	●	9
SPVQ361000	1	2	1±0.5N	Non shorting	Push	With wire (Downwards)	With a screw hole	5.3×13.0×8.35	●	●	●	10
SPVQ361100	1	2	1±0.5N	Non shorting	Push	With wire (Downwards)	Boss - right side	5.3×13.0×8.35	●	●	●	11
SPVQ361200	1	2	1±0.5N	Non shorting	Push	With wire (Downwards)	Boss - left side	5.3×13.0×8.35	●	●	●	12
SPVQ361300	1	2	1±0.5N	Non shorting	Push	With wire (Downwards)	Boss - both sides	5.3×13.0×8.35	●	●	●	13
SPVQ361400	1	1	1±0.5N	Non shorting	Push	With wire (Right side)	With a screw hole	5.3×13.0×8.35	●	●	●	14
SPVQ361500	1	1	1±0.5N	Non shorting	Push	With wire (Right side)	Boss - right side	5.3×13.0×8.35	●	●	●	15
SPVQ361600	1	1	1±0.5N	Non shorting	Push	With wire (Right side)	Boss - left side	5.3×13.0×8.35	●	●	●	16
SPVQ361700	1	1	1±0.5N	Non shorting	Push	With wire (Right side)	Boss - both sides	5.3×13.0×8.35	●	●	●	17
SPVQ361800	1	1	1±0.5N	Non shorting	Push	With wire (Left side)	Boss - right side	5.3×13.0×8.35	●	●	●	18
SPVQ361900	1	1	1±0.5N	Non shorting	Push	With wire (Left side)	Boss - left side	5.3×13.0×8.35	●	●	●	19
SPVQ362000	1	1	1±0.5N	Non shorting	Push	With wire (Left side)	Boss - both sides	5.3×13.0×8.35	●	●	●	20
SPVQ370400	1	2	3N max.	Non shorting	Actuator A	For PC board	Without boss	5.3×13.0×8.35	●	●	●	21
SPVQ370300	1	2	3N max.	Non shorting	Actuator A	For PC board	Boss - right side	5.3×13.0×8.35	●	●	●	22
SPVQ370200	1	2	3N max.	Non shorting	Actuator A	For PC board	Boss - left side	5.3×13.0×8.35	●	●	●	23
SPVQ370100	1	2	3N max.	Non shorting	Actuator A	For PC board	Boss - both sides	5.3×13.0×8.35	●	●	●	24

**Water-proof Type  
SPVQ3 Series**

Products No.	Poles	Positions	Operating force	Changeover timing	Operation part shape	Terminal type	Main body form	Dimensions (W×D×H) (mm)	Water-proof	Dust-proof	Automotive	Drawing No.
SPVQ370700	1	2	3N max.	Non shorting	Actuator A	For Lead	Boss - right side	5.3×13.0×8.35	●	●	●	25
SPVQ370600	1	2	3N max.	Non shorting	Actuator A	For Lead	Boss - left side	5.3×13.0×8.35	●	●	●	26
SPVQ370500	1	2	3N max.	Non shorting	Actuator A	For Lead	Boss - both sides	5.3×13.0×8.35	●	●	●	27
SPVQ370900	1	2	3N max.	Non shorting	Actuator A	Angle (Right)	Boss - right side	5.3×13.0×8.35	●	●	●	28
SPVQ370800	1	2	3N max.	Non shorting	Actuator A	Angle (Left)	Boss - left side	5.3×13.0×8.35	●	●	●	29
SPVQ350100	1	2	3N max.	Non shorting	Actuator A	With wire (Downwards)	With a screw hole	5.3×13.0×8.35	●	●	●	30
SPVQ350200	1	2	3N max.	Non shorting	Actuator A	With wire (Downwards)	Boss - right side	5.3×13.0×8.35	●	●	●	31
SPVQ350300	1	2	3N max.	Non shorting	Actuator A	With wire (Downwards)	Boss - left side	5.3×13.0×8.35	●	●	●	32
SPVQ350400	1	2	3N max.	Non shorting	Actuator A	With wire (Downwards)	Boss - both sides	5.3×13.0×8.35	●	●	●	33
SPVQ350600	1	1	3N max.	Non shorting	Actuator A	With wire (Right side)	Boss - right side	5.3×13.0×8.35	●	●	●	34
SPVQ350700	1	1	3N max.	Non shorting	Actuator A	With wire (Right side)	Boss - left side	5.3×13.0×8.35	●	●	●	35
SPVQ350800	1	1	3N max.	Non shorting	Actuator A	With wire (Right side)	Boss - both sides	5.3×13.0×8.35	●	●	●	36
SPVQ350900	1	1	3N max.	Non shorting	Actuator A	With wire (Left side)	Boss - right side	5.3×13.0×8.35	●	●	●	37
SPVQ351000	1	1	3N max.	Non shorting	Actuator A	With wire (Left side)	Boss - left side	5.3×13.0×8.35	●	●	●	38
SPVQ351100	1	1	3N max.	Non shorting	Actuator A	With wire (Left side)	Boss - both sides	5.3×13.0×8.35	●	●	●	39
SPVQ371300	1	2	3N max.	Non shorting	Actuator B	For PC board	Without boss	5.3×13.0×8.35	●	●	●	40
SPVQ371200	1	2	3N max.	Non shorting	Actuator B	For PC board	Boss - right side	5.3×13.0×8.35	●	●	●	41
SPVQ371100	1	2	3N max.	Non shorting	Actuator B	For PC board	Boss - left side	5.3×13.0×8.35	●	●	●	42
SPVQ371000	1	2	3N max.	Non shorting	Actuator B	For PC board	Boss - both sides	5.3×13.0×8.35	●	●	●	43
SPVQ371600	1	2	3N max.	Non shorting	Actuator B	For Lead	Boss - right side	5.3×13.0×8.35	●	●	●	44
SPVQ371500	1	2	3N max.	Non shorting	Actuator B	For Lead	Boss - left side	5.3×13.0×8.35	●	●	●	45
SPVQ371400	1	2	3N max.	Non shorting	Actuator B	For Lead	Boss - both sides	5.3×13.0×8.35	●	●	●	46
SPVQ371800	1	2	3N max.	Non shorting	Actuator B	Angle (Right)	Boss - right side	5.3×13.0×8.35	●	●	●	47
SPVQ371700	1	2	3N max.	Non shorting	Actuator B	Angle (Left)	Boss - left side	5.3×13.0×8.35	●	●	●	48
SPVQ351200	1	2	3N max.	Non shorting	Actuator B	With wire (Downwards)	With a screw hole	5.3×13.0×8.35	●	●	●	49
SPVQ351300	1	2	3N max.	Non shorting	Actuator B	With wire (Downwards)	Boss - right side	5.3×13.0×8.35	●	●	●	50
SPVQ351400	1	2	3N max.	Non shorting	Actuator B	With wire (Downwards)	Boss - left side	5.3×13.0×8.35	●	●	●	51
SPVQ351500	1	2	3N max.	Non shorting	Actuator B	With wire (Downwards)	Boss - both sides	5.3×13.0×8.35	●	●	●	52
SPVQ351700	1	1	3N max.	Non shorting	Actuator B	With wire (Right side)	Boss - right side	5.3×13.0×8.35	●	●	●	53
SPVQ351800	1	1	3N max.	Non shorting	Actuator B	With wire (Right side)	Boss - left side	5.3×13.0×8.35	●	●	●	54
SPVQ351900	1	1	3N max.	Non shorting	Actuator B	With wire (Right side)	Boss - both sides	5.3×13.0×8.35	●	●	●	55
SPVQ352000	1	1	3N max.	Non shorting	Actuator B	With wire (Left side)	Boss - right side	5.3×13.0×8.35	●	●	●	56
SPVQ352100	1	1	3N max.	Non shorting	Actuator B	With wire (Left side)	Boss - left side	5.3×13.0×8.35	●	●	●	57
SPVQ352200	1	1	3N max.	Non shorting	Actuator B	With wire (Left side)	Boss - both sides	5.3×13.0×8.35	●	●	●	58

Water-proof Type  
SPVQ3 Series

## ⚠ Note

1. This catalog shows only outline specifications. When using the products, please obtain formal specifications for supply.
2. Unless specified, the length of the lead wire is 250mm. Color is either Red, Black or Yellow. For length modification, please contact us.
3. This unit cannot be used in water (IP6K7 rating, except for terminal).
4. Unless circuit is specified, wired (downward) types will apply three wires.
5. Please specify circuit (N. O. or N. C.) for wired (side) types. Unless specified, the circuit will apply N. O.
6. Please place purchase orders per minimum order unit (integer).
7. This products can be used in vehicles.  
Although these products are designed to perform over a wide operating temperature range, please ensure that you receive and read the formal delivery specifications before use.

## ■ Packing Specifications

## Tray

Products No.	Number of packages(pcs.)		Export package measurements (mm)
	1 case / Japan	1 case / export packing	
SPVQ380400 SPVQ380300 SPVQ380201 SPVQ380100 SPVQ380700 SPVQ380600 SPVQ380500 SPVQ380900 SPVQ380800 SPVQ370400 SPVQ370300 SPVQ370200 SPVQ370100 SPVQ370700 SPVQ370600 SPVQ370500 SPVQ370900 SPVQ370800 SPVQ371300 SPVQ371200 SPVQ371100 SPVQ371000 SPVQ371600 SPVQ371500 SPVQ371400 SPVQ371800 SPVQ371700	1,300	5,200	540 x 360 x 290

## Bulk

Products No.	Number of packages(pcs.)		Export package measurements (mm)
	1 case / Japan	1 case / export packing	
SPVQ361000 SPVQ361100 SPVQ361200 SPVQ361300 SPVQ361400 SPVQ361500 SPVQ361600 SPVQ361700 SPVQ361800 SPVQ361900 SPVQ362000	400	1,600	555 x 375 x 223
SPVQ350100 SPVQ350200 SPVQ350300 SPVQ350400 SPVQ351200 SPVQ351300 SPVQ351400 SPVQ351500	180	720	540 x 360 x 270
SPVQ350600 SPVQ350700 SPVQ350800 SPVQ350900 SPVQ351000 SPVQ351100 SPVQ351700 SPVQ351800 SPVQ351900 SPVQ352000 SPVQ352100 SPVQ352200	168	672	555 x 375 x 223

Water-proof Type  
SPVQ3 Series

Drawing No.1

■ Dimensions

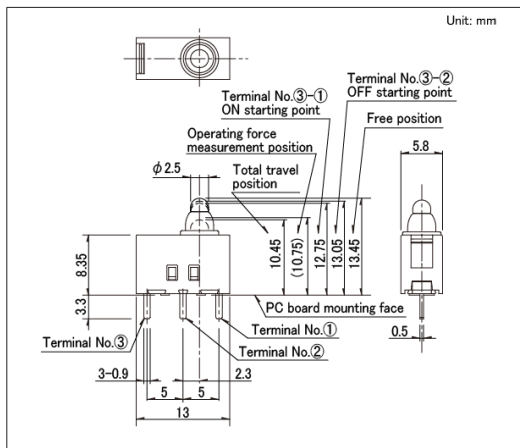

■ Circuit Diagram

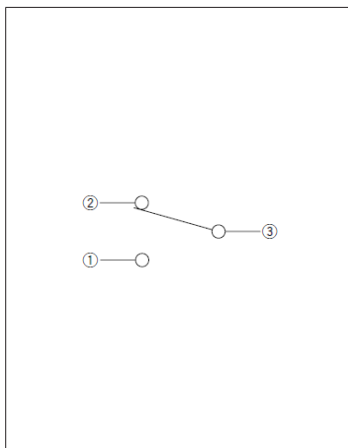

Drawing No.2

■ Dimensions

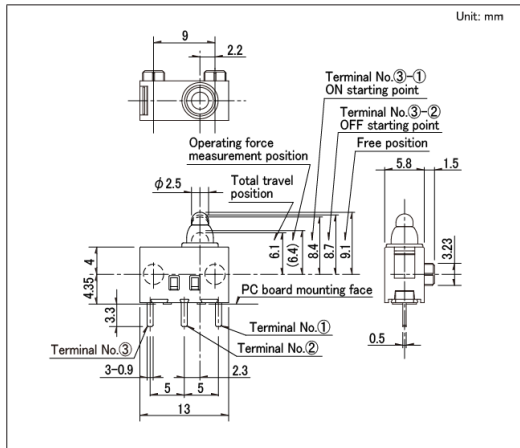

■ Circuit Diagram

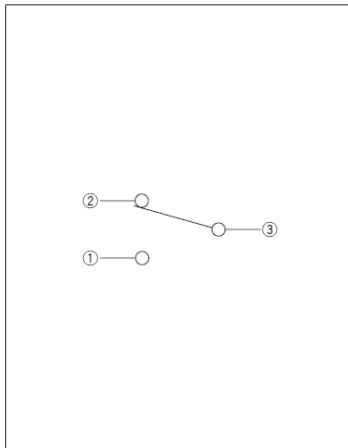

Drawing No.3

■ Dimensions

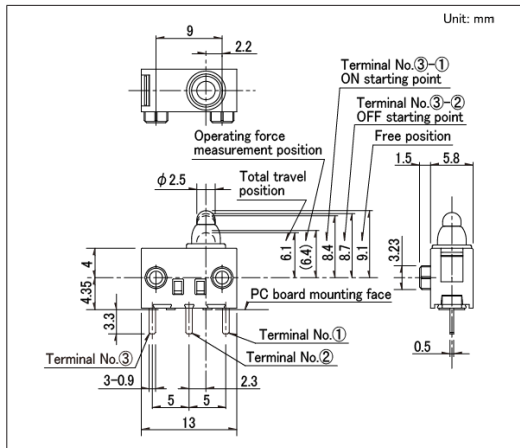

■ Circuit Diagram

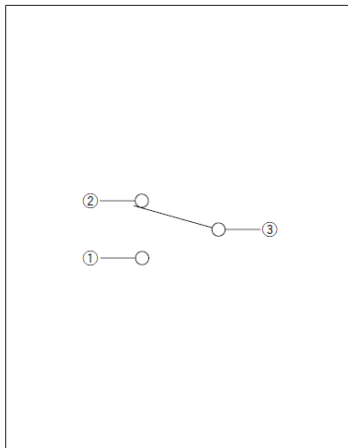

Water-proof Type  
SPVQ3 Series

Drawing No.4

■ Dimensions

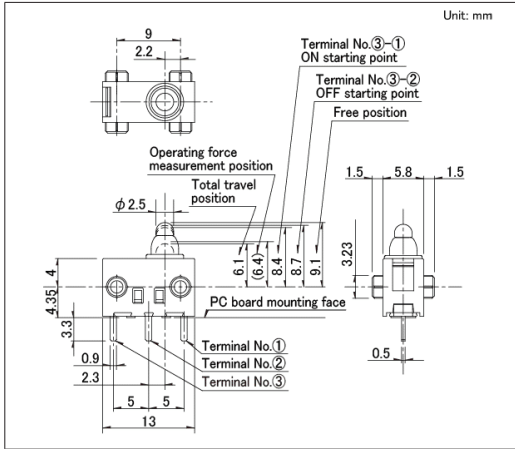

■ Circuit Diagram

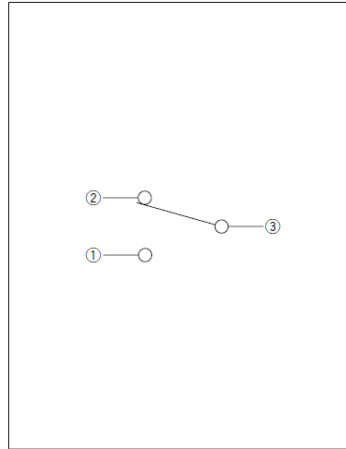

Drawing No.5

■ Dimensions

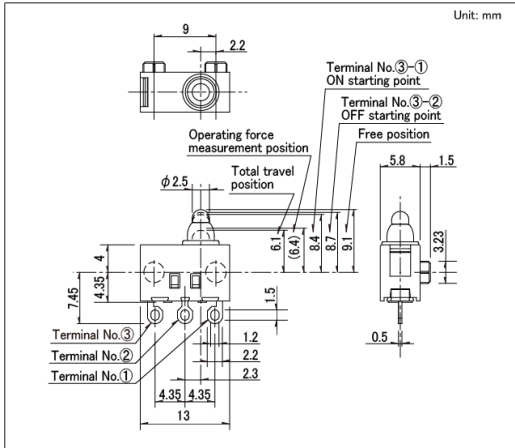

■ Circuit Diagram

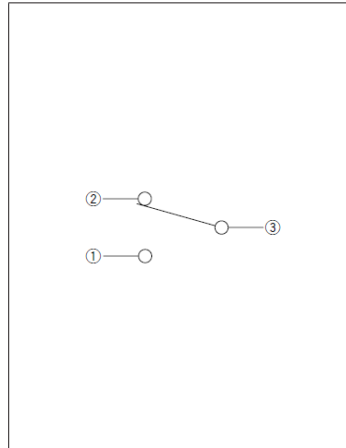

Drawing No.6

■ Dimensions

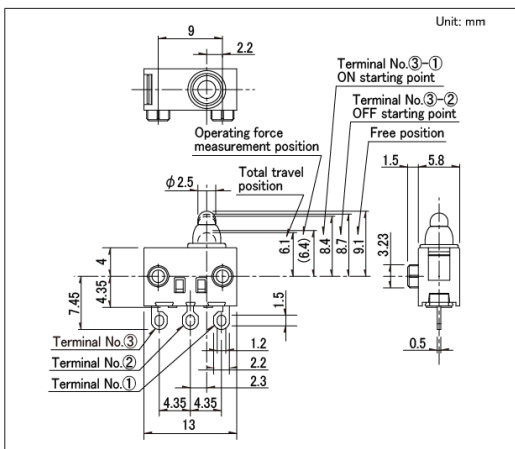

■ Circuit Diagram

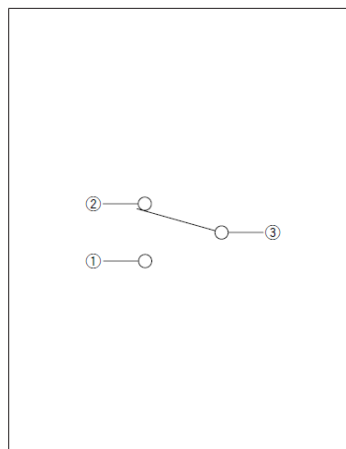

Water-proof Type  
SPVQ3 Series

Drawing No.7

■ Dimensions

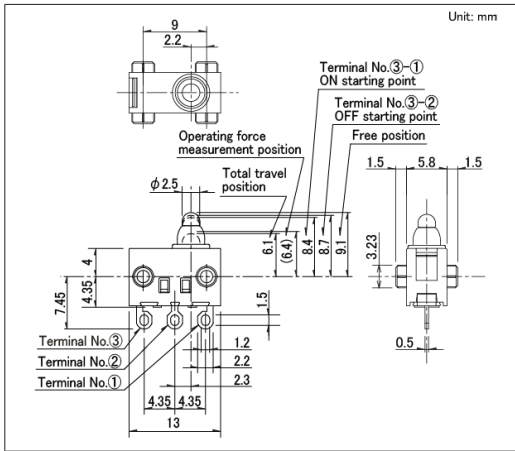

■ Circuit Diagram

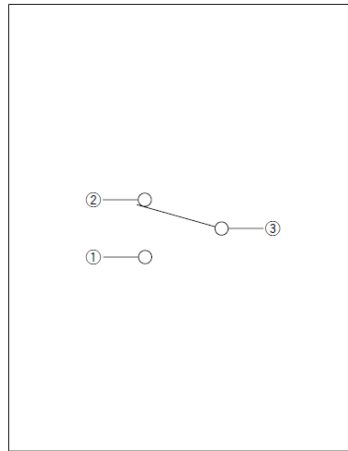

Drawing No.8

■ Dimensions

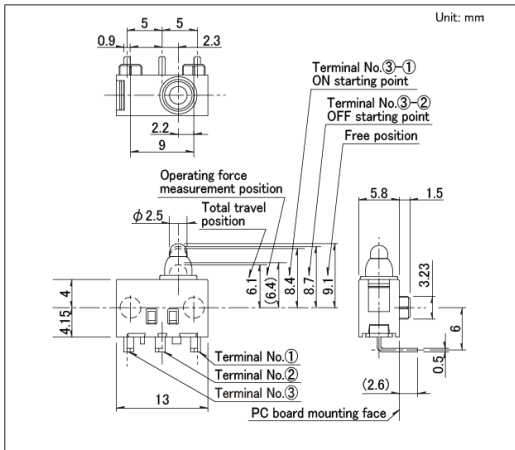

■ Circuit Diagram

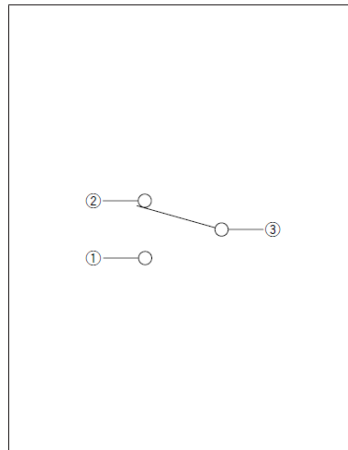

Drawing No.9

■ Dimensions

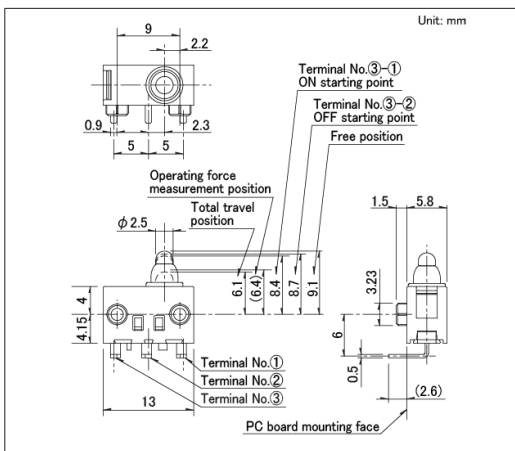

■ Circuit Diagram

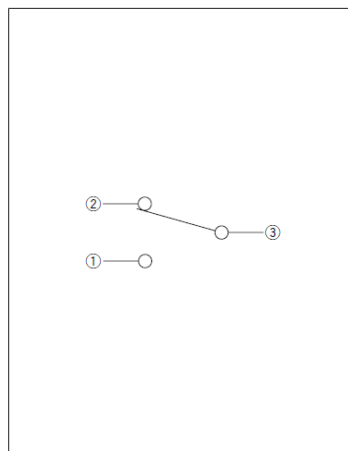

Water-proof Type  
SPVQ3 Series

Drawing No.10

■ Dimensions

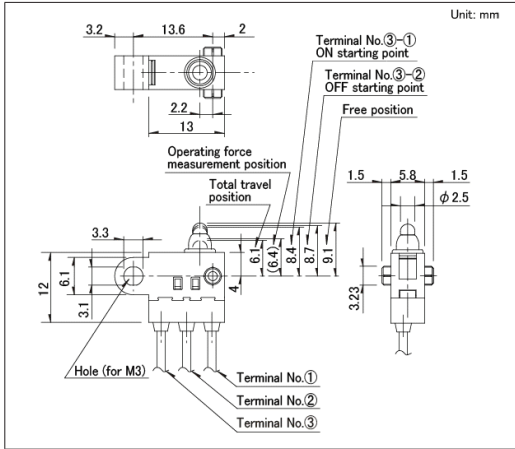

■ Circuit Diagram

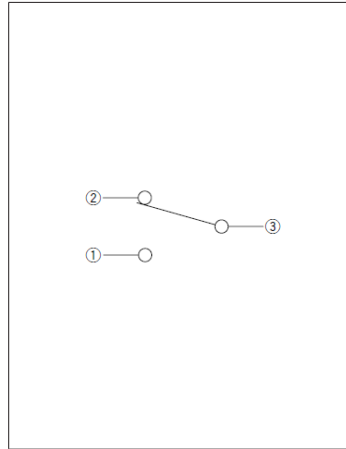

Drawing No.11

■ Dimensions

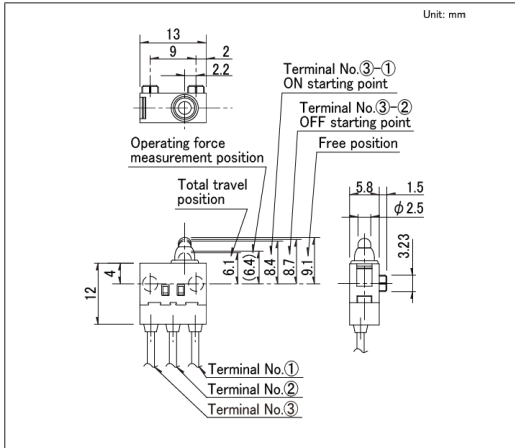

■ Circuit Diagram

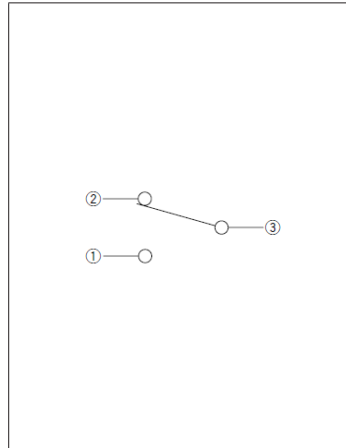

Drawing No.12

■ Dimensions

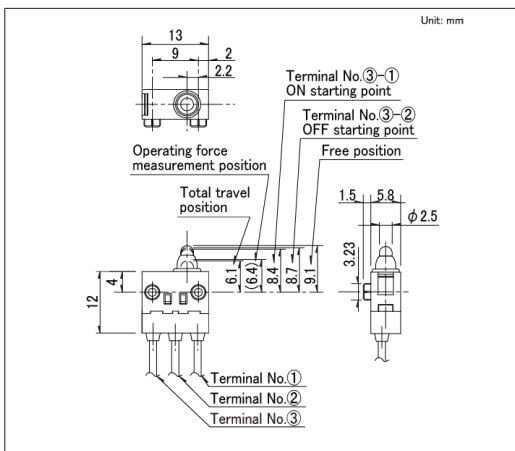

■ Circuit Diagram

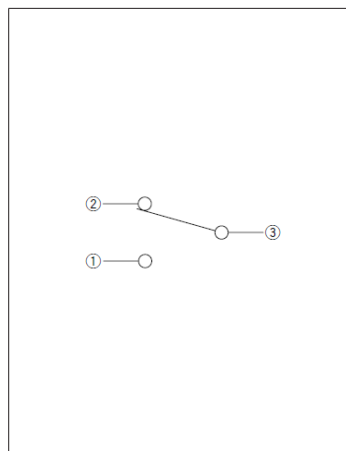

Water-proof Type  
SPVQ3 Series

Drawing No.13

■ Dimensions

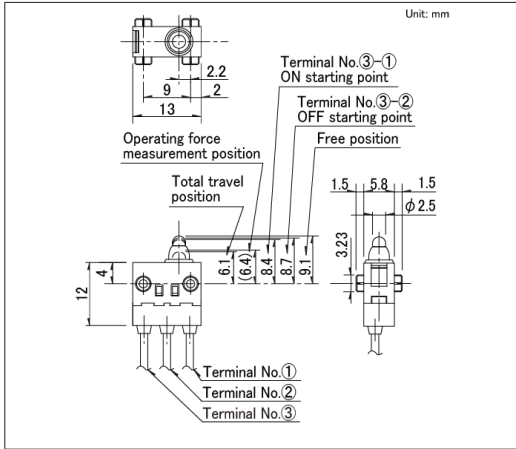

■ Circuit Diagram

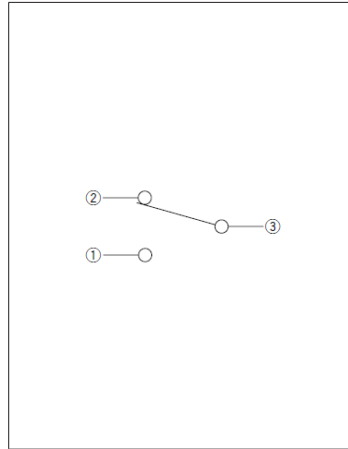

Drawing No.14

■ Dimensions

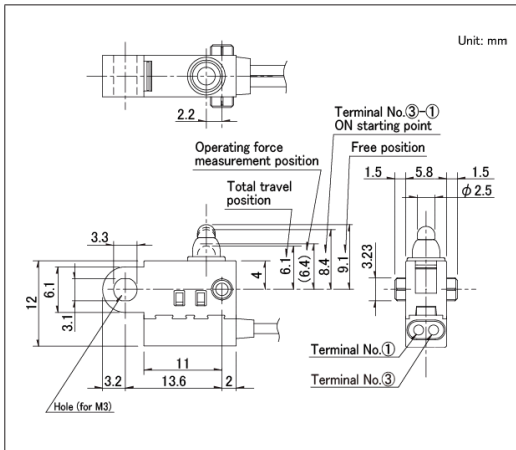

■ Circuit Diagram

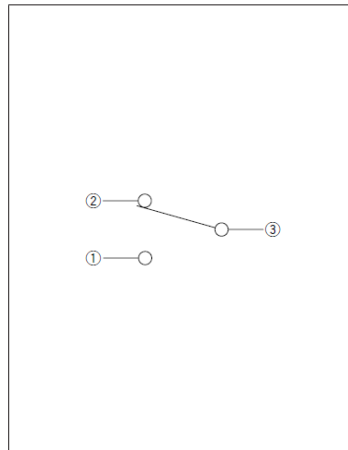

Drawing No.15

■ Dimensions

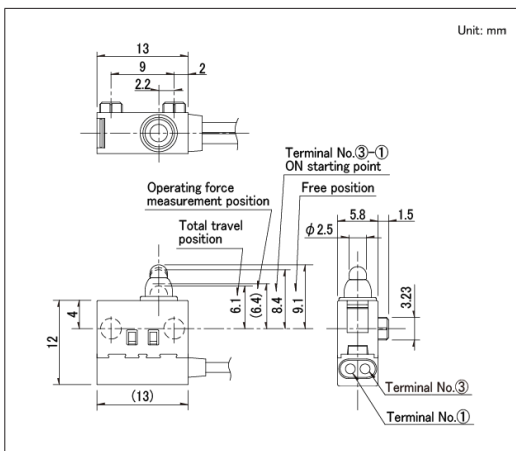

■ Circuit Diagram

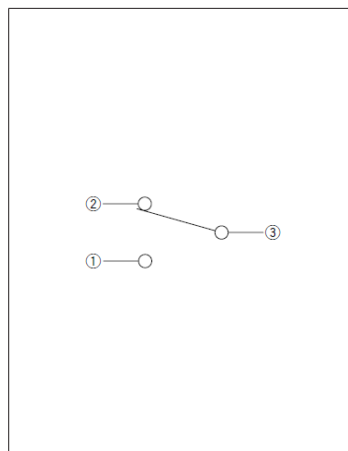

Water-proof Type  
SPVQ3 Series

Drawing No.16

■ Dimensions

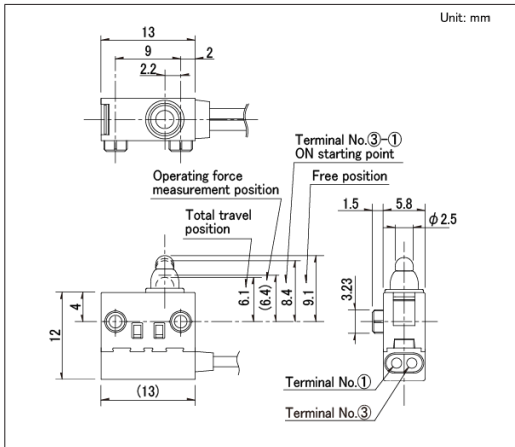

■ Circuit Diagram

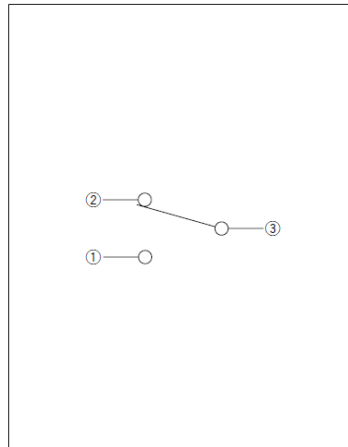

Drawing No.17

■ Dimensions

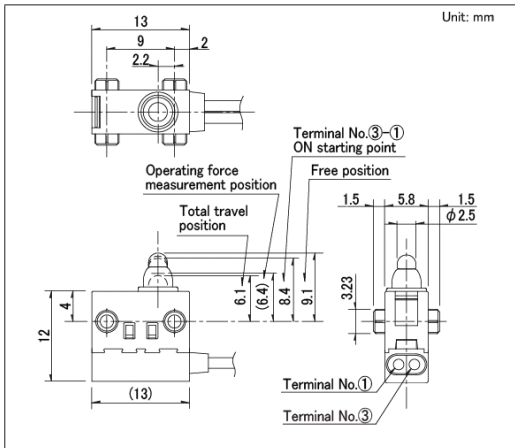

■ Circuit Diagram

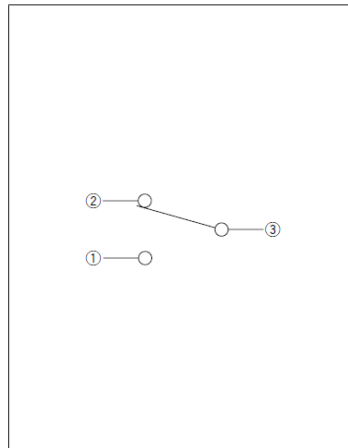

Drawing No.18

■ Dimensions

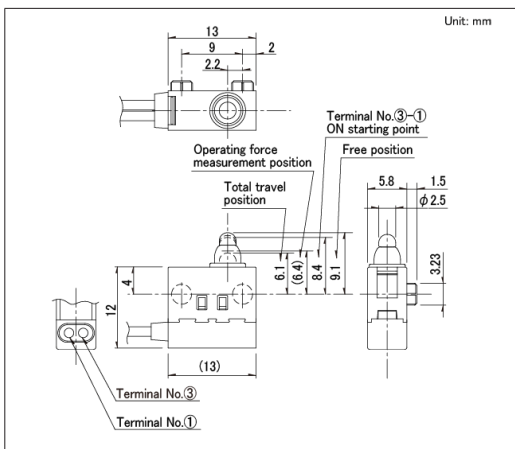

■ Circuit Diagram

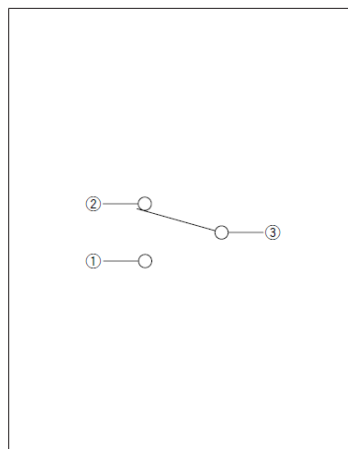

Water-proof Type  
SPVQ3 Series

Drawing No.19

■ Dimensions

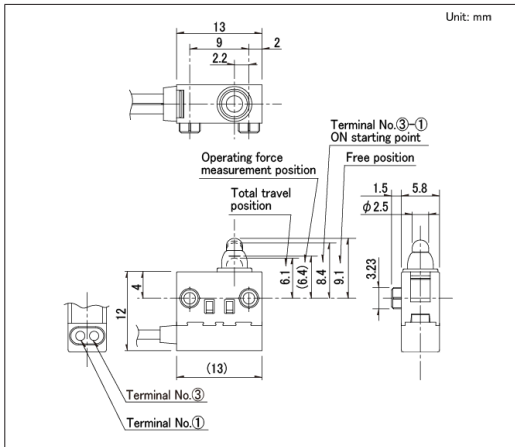

■ Circuit Diagram

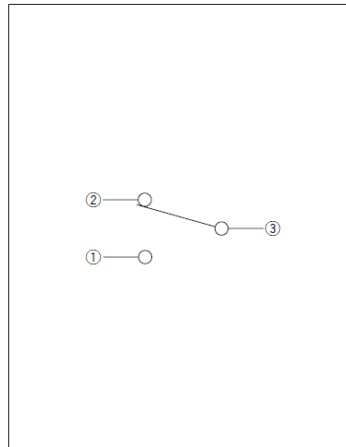

Drawing No.20

■ Dimensions

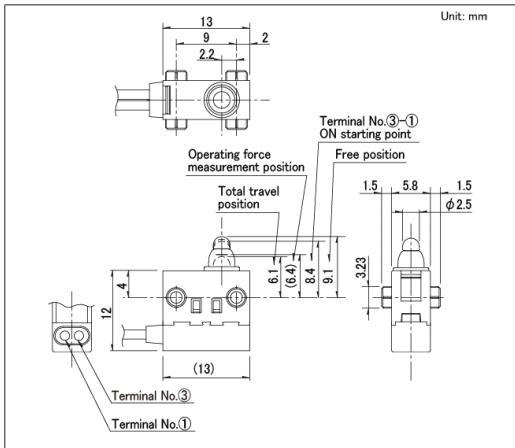

■ Circuit Diagram

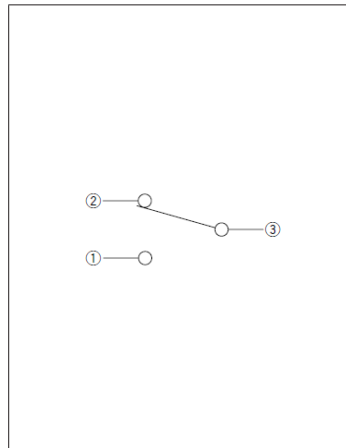

Drawing No.21

■ Dimensions

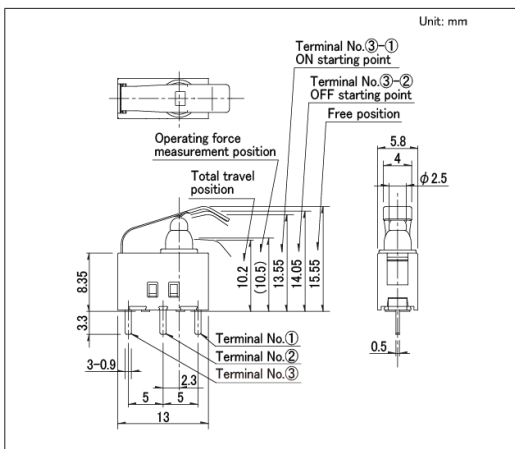

■ Circuit Diagram

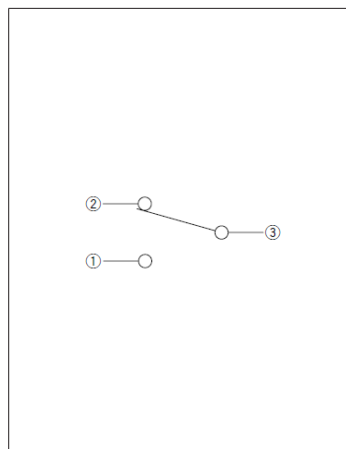

Water-proof Type  
SPVQ3 Series

Drawing No.22

■ Dimensions

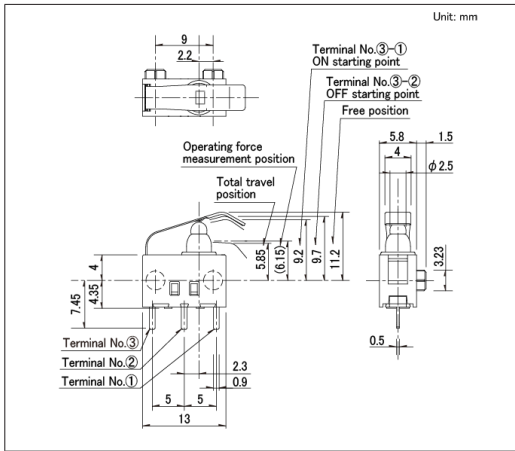

■ Circuit Diagram

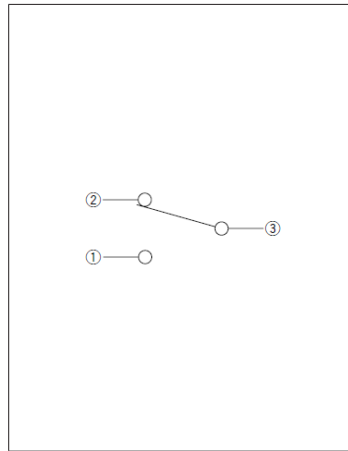

Drawing No.23

■ Dimensions

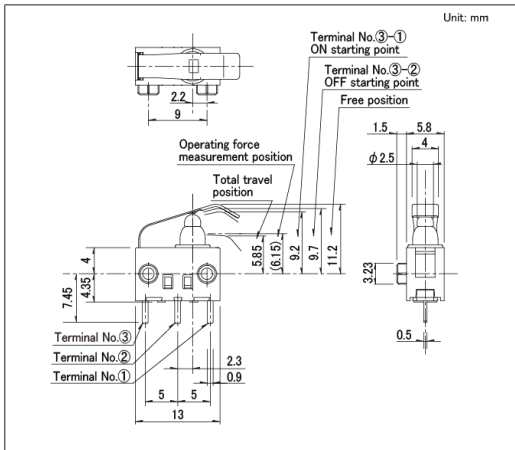

■ Circuit Diagram

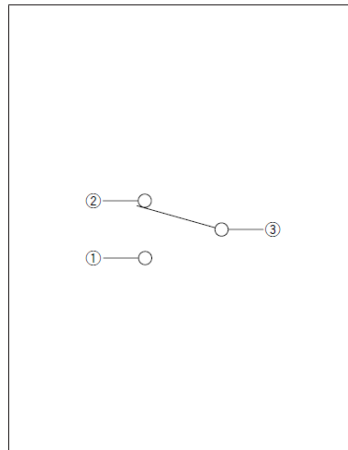

Drawing No.24

■ Dimensions

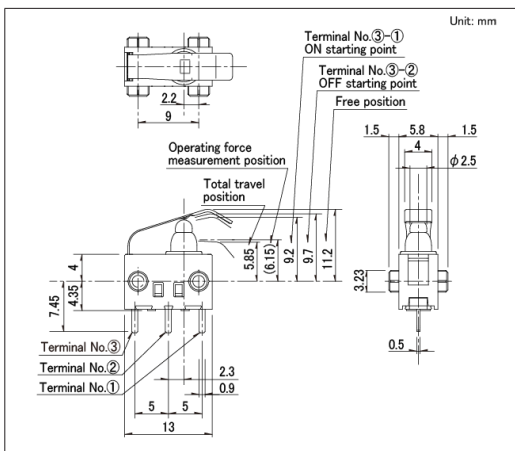

■ Circuit Diagram

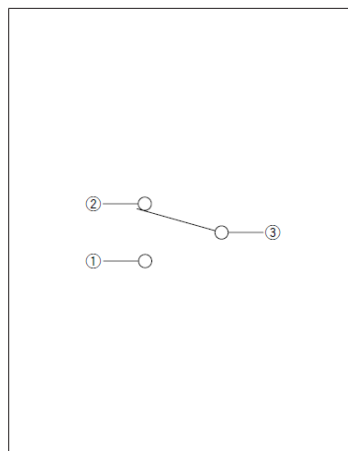

Water-proof Type  
SPVQ3 Series

Drawing No.25

■ Dimensions

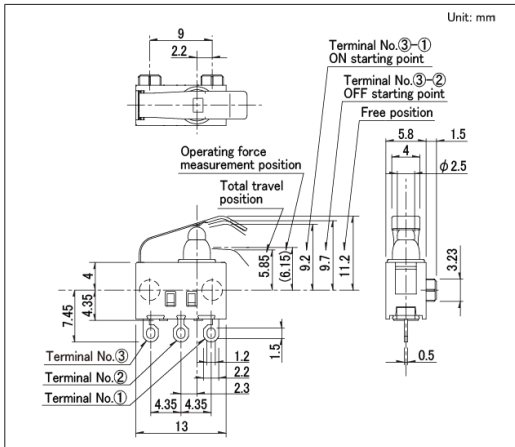

■ Circuit Diagram

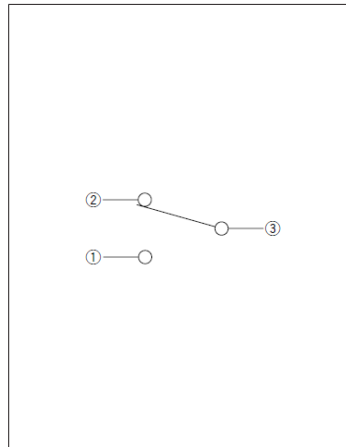

Drawing No.26

■ Dimensions

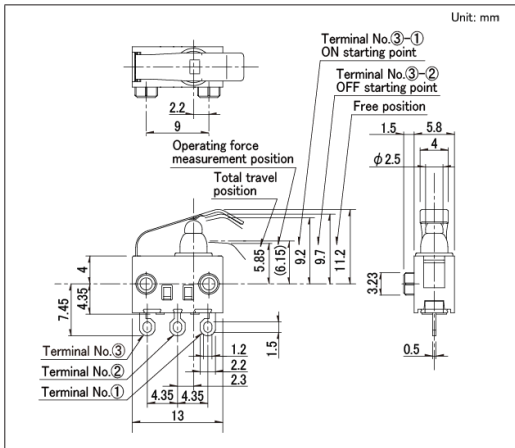

■ Circuit Diagram

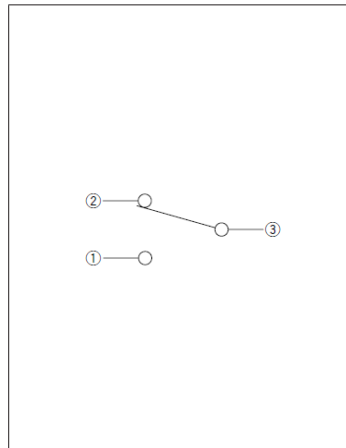

Drawing No.27

■ Dimensions

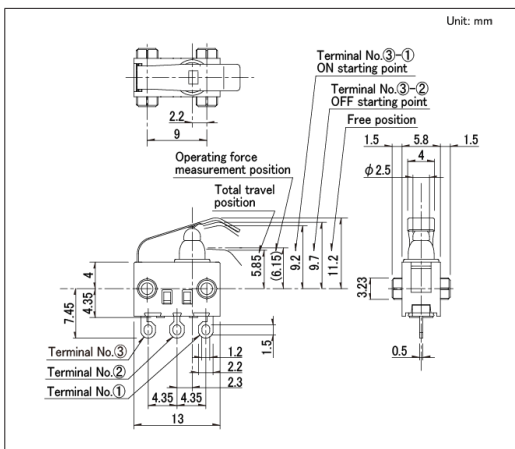

■ Circuit Diagram

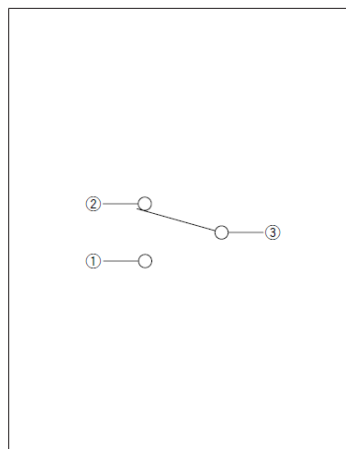

Water-proof Type  
SPVQ3 Series

Drawing No.28

■ Dimensions

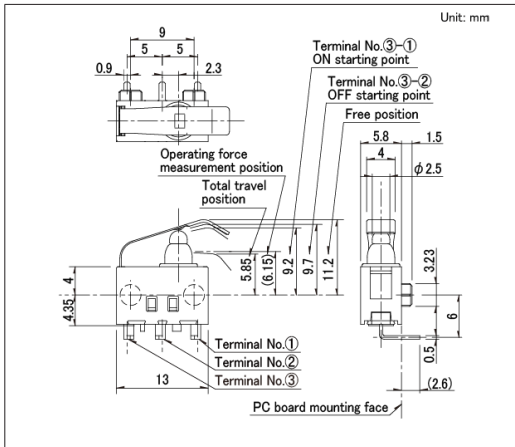

■ Circuit Diagram

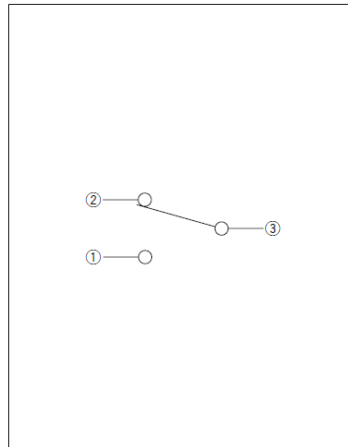

Drawing No.29

■ Dimensions

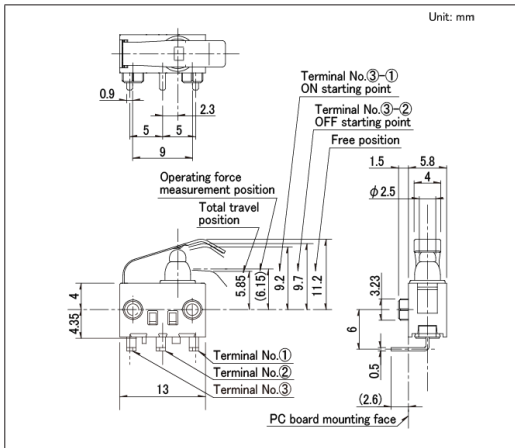

■ Circuit Diagram

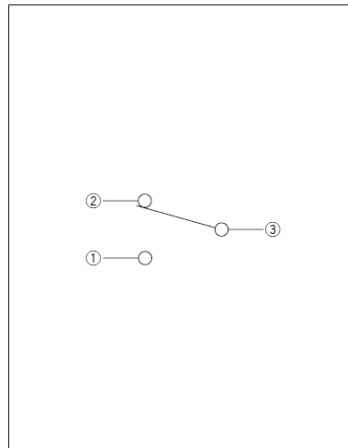

Drawing No.30

■ Dimensions

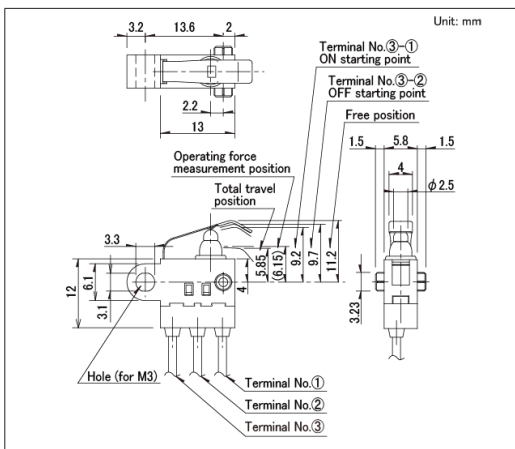

■ Circuit Diagram

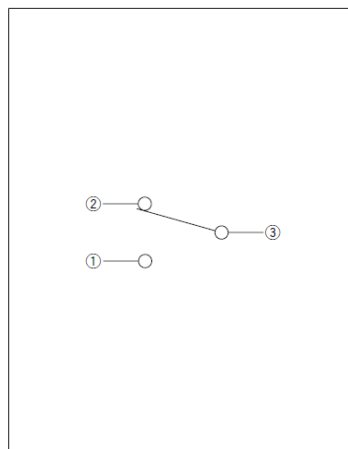

Water-proof Type  
SPVQ3 Series

Drawing No.31

■ Dimensions

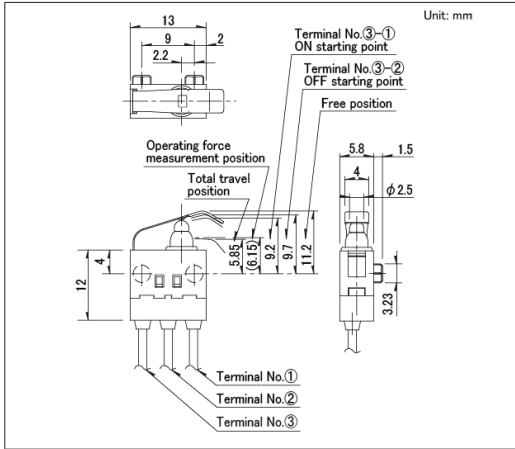

■ Circuit Diagram

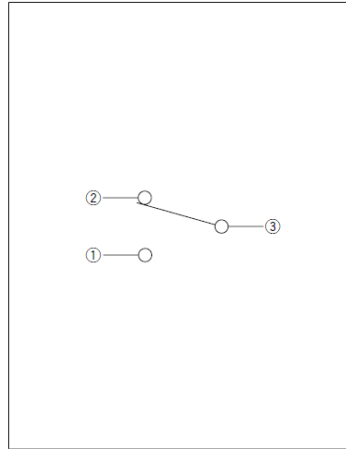

Drawing No.32

■ Dimensions

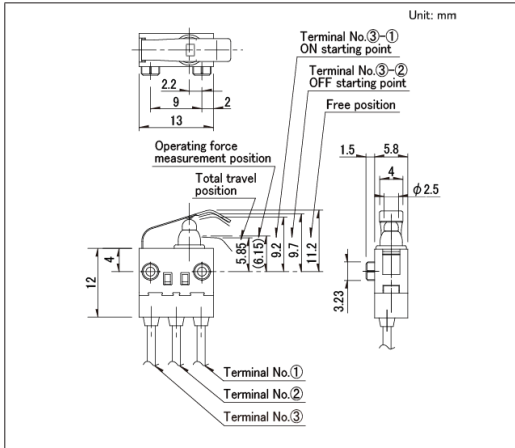

■ Circuit Diagram

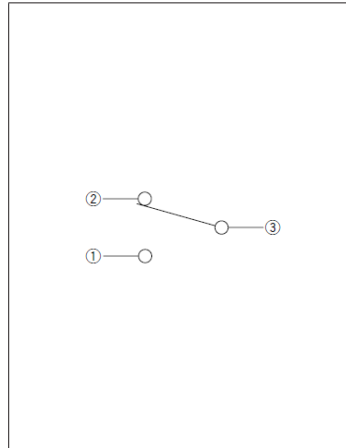

Drawing No.33

■ Dimensions

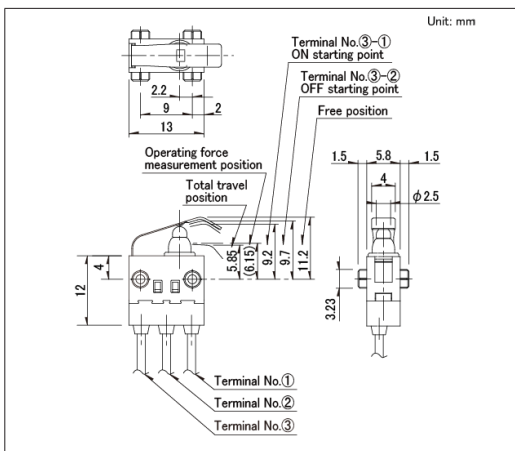

■ Circuit Diagram

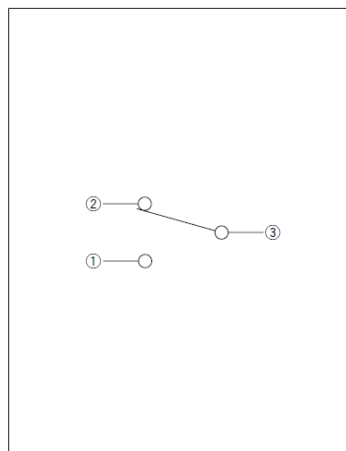

Water-proof Type  
SPVQ3 Series

Drawing No.34

■ Dimensions

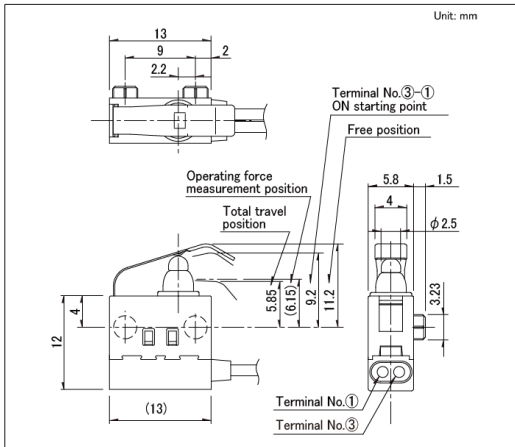

■ Circuit Diagram

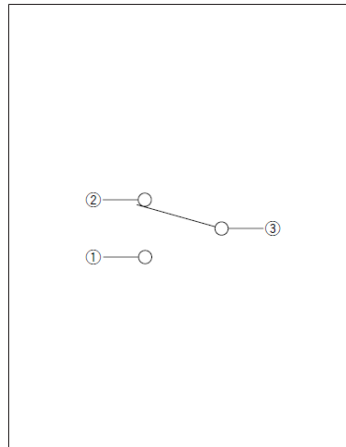

Drawing No.35

■ Dimensions

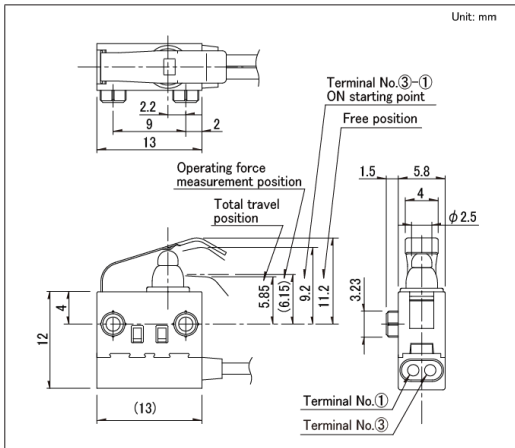

■ Circuit Diagram

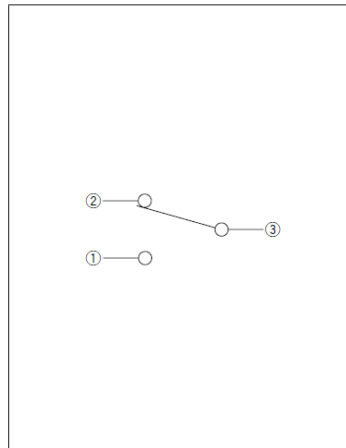

Drawing No.36

■ Dimensions

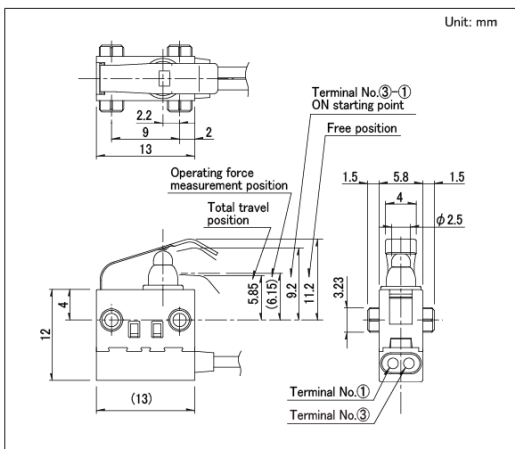

■ Circuit Diagram

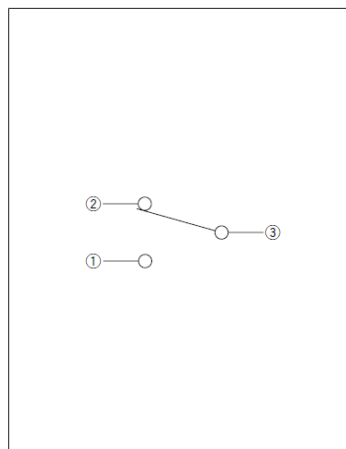

Water-proof Type  
SPVQ3 Series

Drawing No.37

■ Dimensions

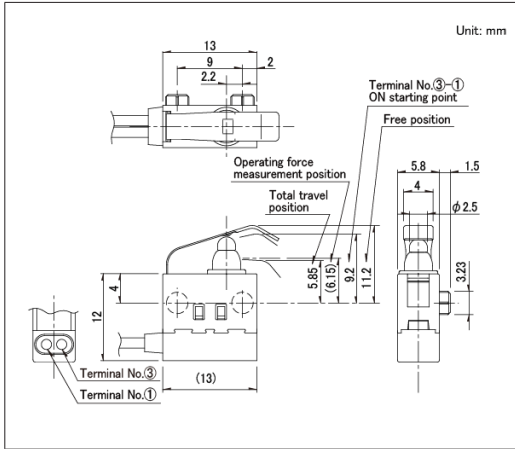

■ Circuit Diagram

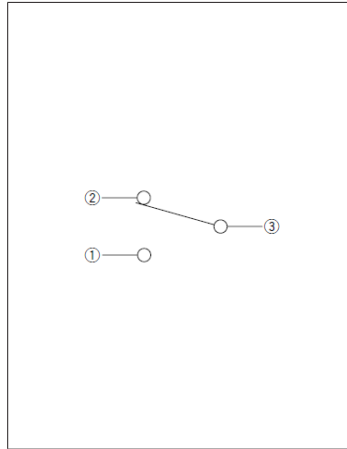

Drawing No.38

■ Dimensions

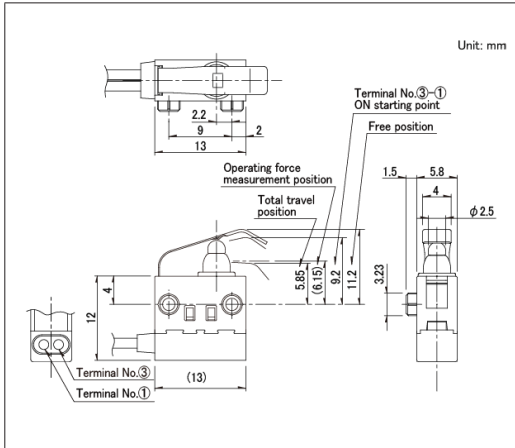

■ Circuit Diagram

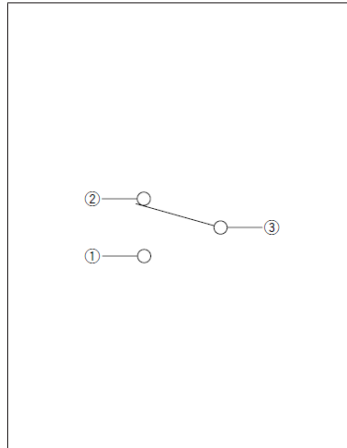

Drawing No.39

■ Dimensions

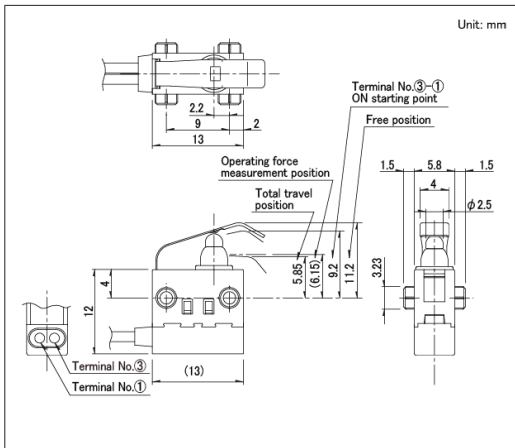

■ Circuit Diagram

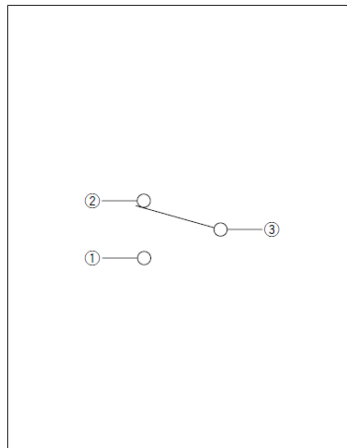

Water-proof Type  
SPVQ3 Series

Drawing No.40

■ Dimensions

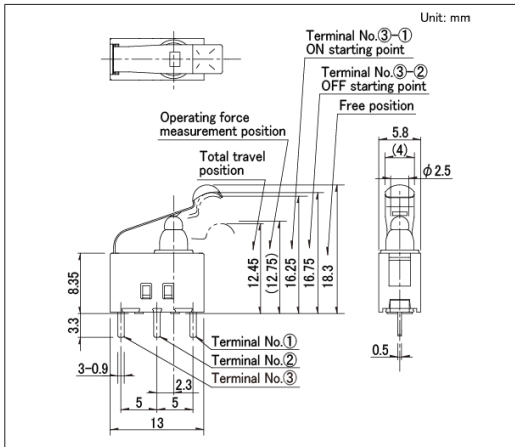

■ Circuit Diagram

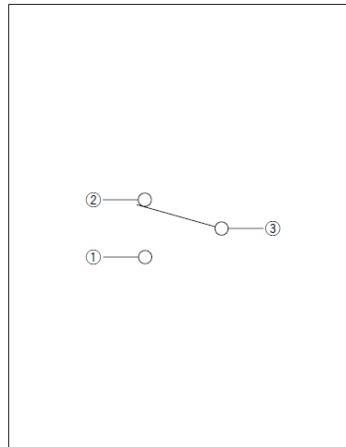

Drawing No.41

■ Dimensions

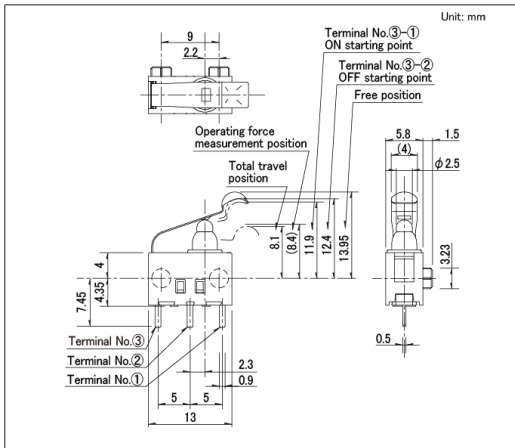

■ Circuit Diagram

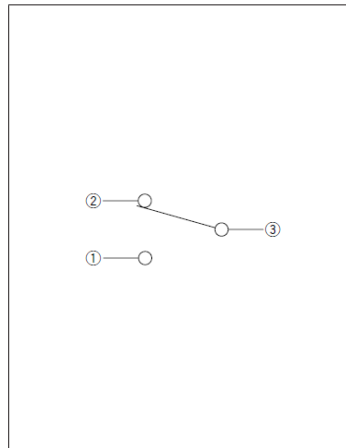

Drawing No.42

■ Dimensions

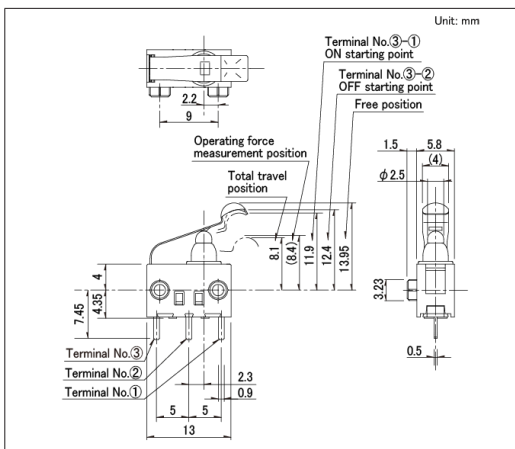

■ Circuit Diagram

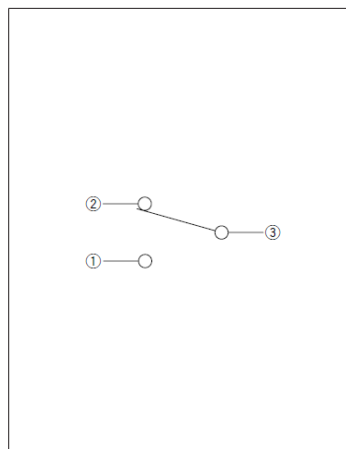

Water-proof Type  
SPVQ3 Series

Drawing No.43

■ Dimensions

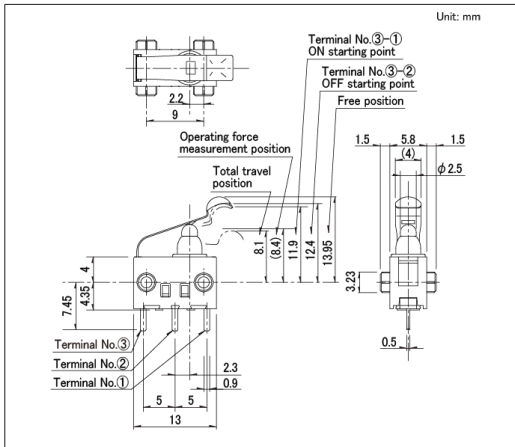

■ Circuit Diagram

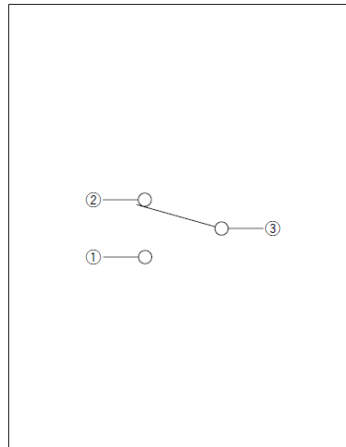

Drawing No.44

■ Dimensions

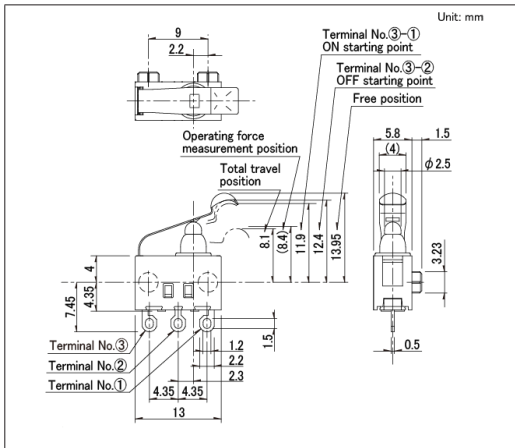

■ Circuit Diagram

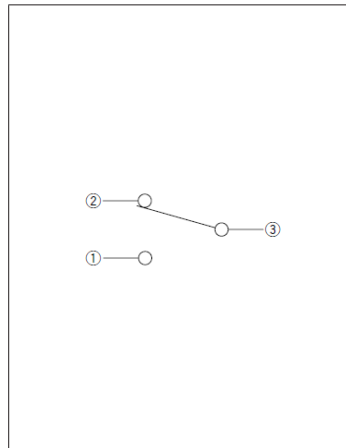

Drawing No.45

■ Dimensions

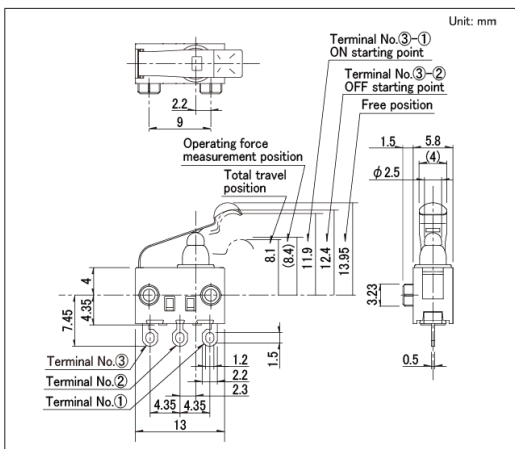

■ Circuit Diagram

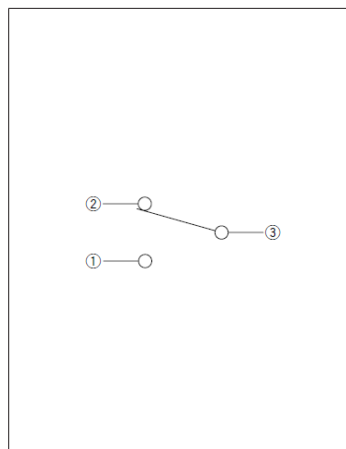



Water-proof Type  
SPVQ3 Series

Drawing No.49

■ Dimensions

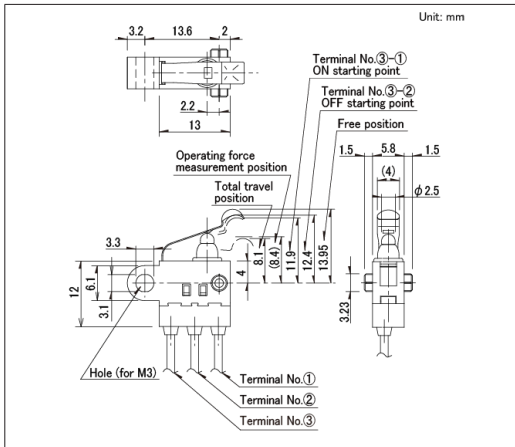

■ Circuit Diagram

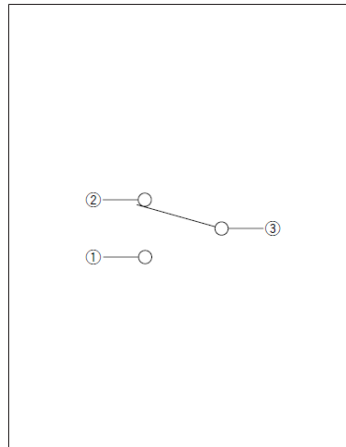

Drawing No.50

■ Dimensions

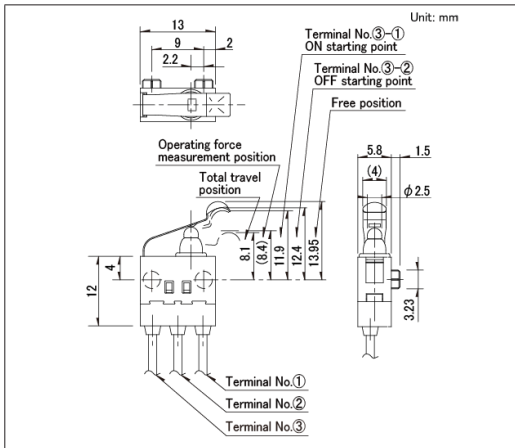

■ Circuit Diagram

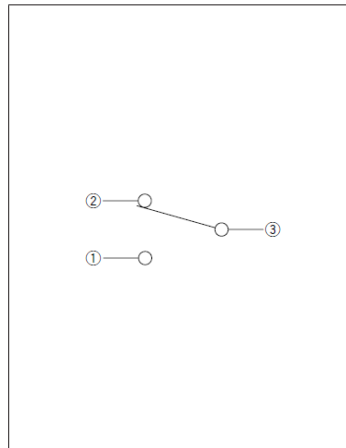

Drawing No.51

■ Dimensions

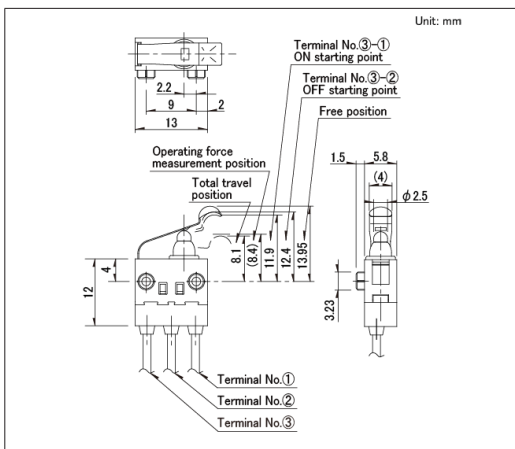

■ Circuit Diagram

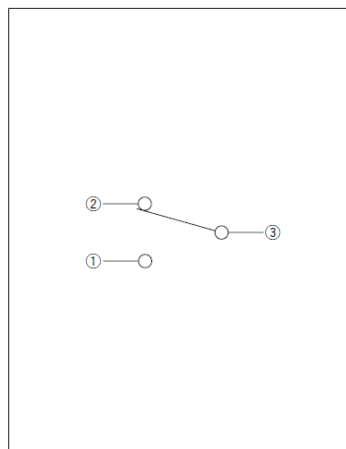

Water-proof Type  
SPVQ3 Series

Drawing No.52

■ Dimensions

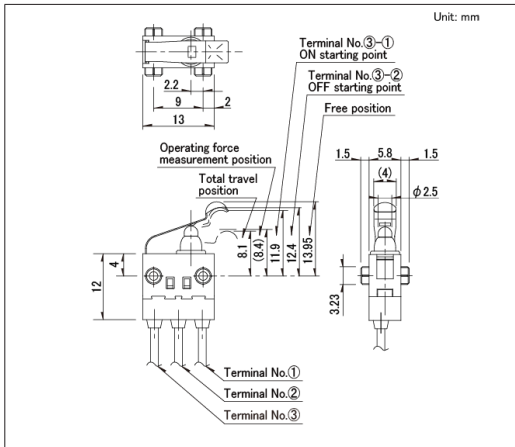

■ Circuit Diagram

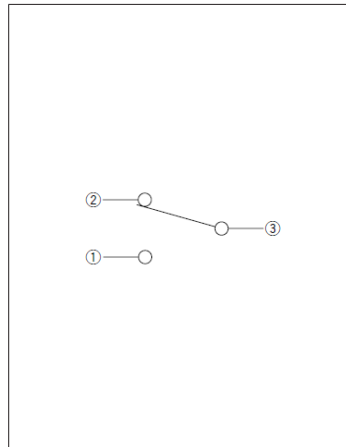

Drawing No.53

■ Dimensions

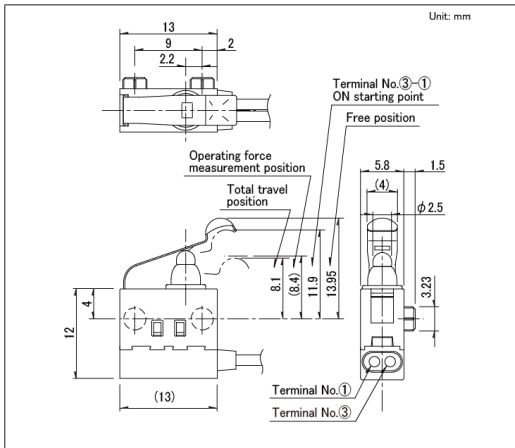

■ Circuit Diagram

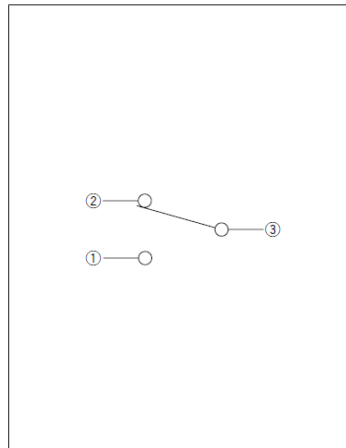

Drawing No.54

■ Dimensions

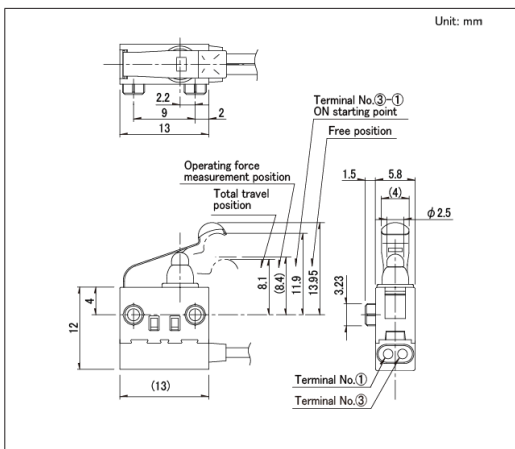

■ Circuit Diagram

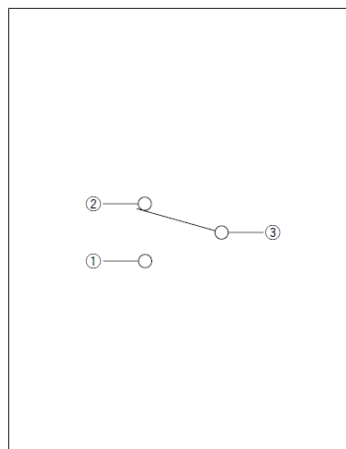

Water-proof Type  
SPVQ3 Series

Drawing No.55

■ Dimensions

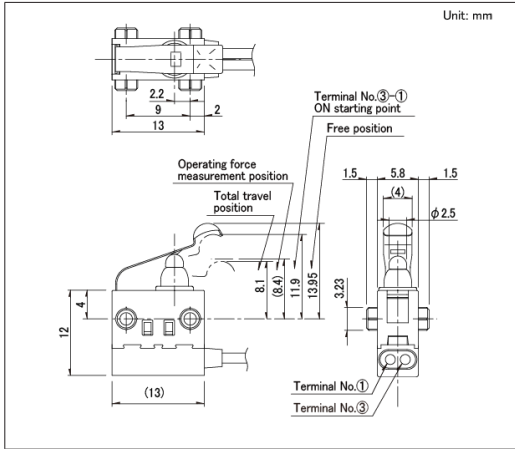

■ Circuit Diagram

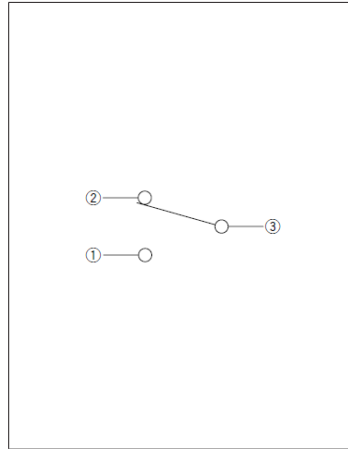

Drawing No.56

■ Dimensions

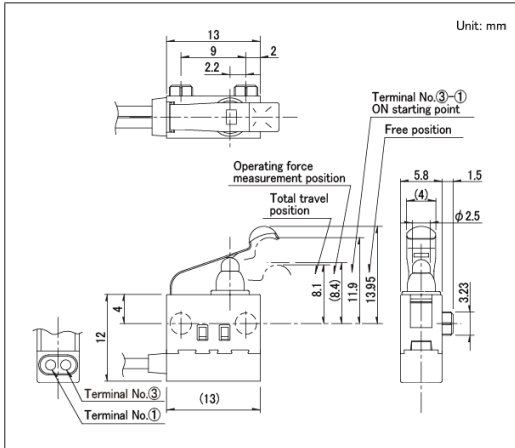

■ Circuit Diagram

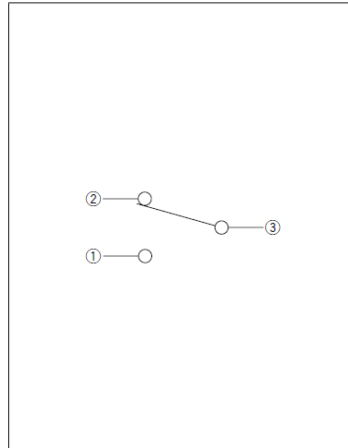

Drawing No.57

■ Dimensions

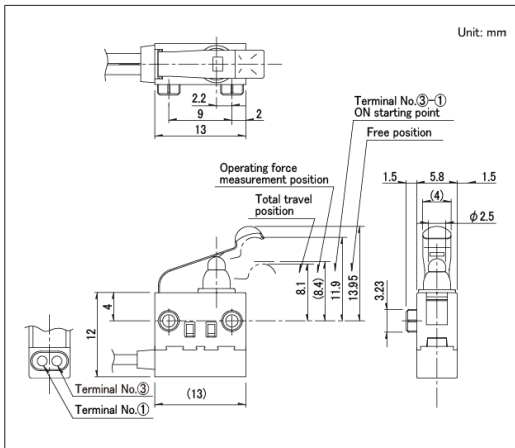

■ Circuit Diagram

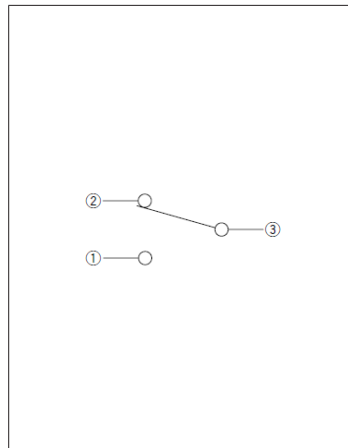

Water-proof Type  
**SPVQ3 Series**

**Drawing No.58**

■ Dimensions

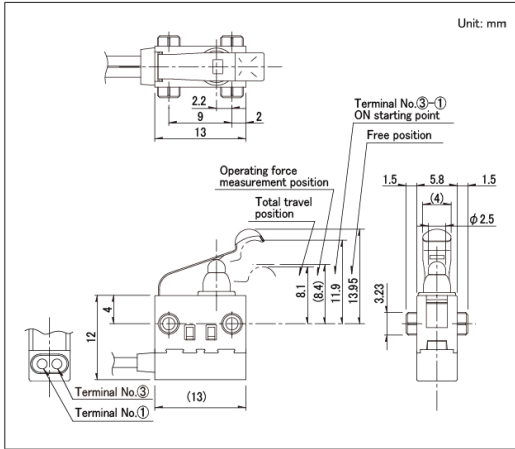

■ Circuit Diagram

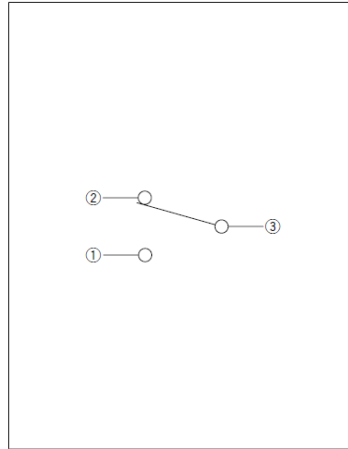

## Water-proof Type SPVQ6 Series

Compact type with body dimensions of 13.3×5.3mm and a height of 7.0mm.

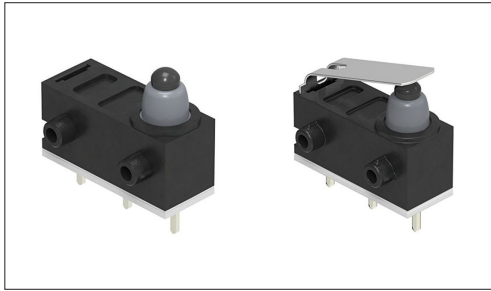

Automotive

Water-proof Type

Dust-proof Type

- Rating(max.)/(min.)(Resistive load):0.1A 12V DC/50μA 5V DC
- Contact resistance(Initial/After operating life):500mΩ max./1Ω max.
- Operating life without load:300,000 cycles
- Operating life with load Rating(max.)(Resistive load):  
300,000 cycles 1Ω max.

Applications:Energy\_Industrial:Robots, drones,Industrial equipment

Home:Major home appliances

Automotive:Hood Latch (Side/Rear/Door/Gear)

### Product List

Products No.	Type	Poles	Positions	Operating force	Changeover timing	Operation part shape	Terminal type	Main body form	Dimensions (W×D×H) (mm)	Water-proof	Dust-proof	Automotive	Drawing No.
SPVQ640102	—	1	2	1±0.5N	Non shorting	Push	For PC board	Boss - right side	5.3×13.3×6.5	●	●	●	1
SPVQ640202		1	2	1±0.5N	Non shorting	Push	For PC board	Boss - left side	5.3×13.3×6.5	●	●	●	2
SPVQ630104		1	2	3N max.	Non shorting	Actuator	For PC board	Boss - right side	5.3×13.3×6.5	●	●	●	3
SPVQ630203		1	2	3N max.	Non shorting	Actuator	For PC board	Boss - left side	5.3×13.3×6.5	●	●	●	4
SPVQ6R	With internal resistor type	1	1	3N max.	Non shorting	Actuator	Press-fit (normal type)	Without boss / Left bending	5.3×13.3×6.5	●	●	●	5

### Note

1. This catalog shows only outline specifications. When using the products, please obtain formal specifications for supply.
2. This unit cannot be used in water (IP6K7 rating, except for terminal).
3. Please place purchase orders per minimum order unit (integer).
4. This products can be used in vehicles.  
Although these products are designed to perform over a wide operating temperature range, please ensure that you receive and read the formal delivery specifications before use.
5. For the Recommended Unit Terminal Shape for Press-Fit Terminals (Normally Open) for SPVQ6R, please check our website.

### Packing Specifications

Tray

Number of packages(pcs.)		Export package measurements (mm)
1 case / Japan	1 case / export packing	
1,500	6,000	540×360×270



Water-proof Type  
SPVQ6 Series

Drawing No.4

■ Dimensions

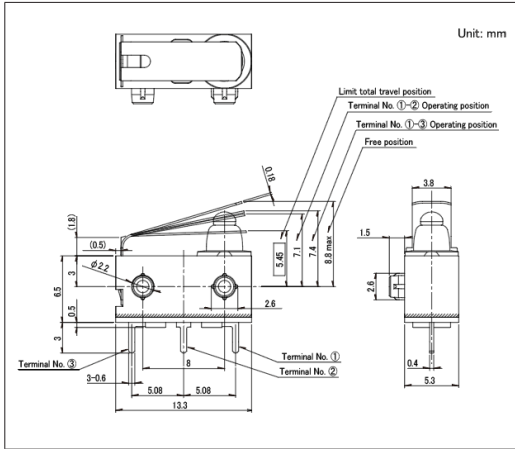

■ Circuit Diagram

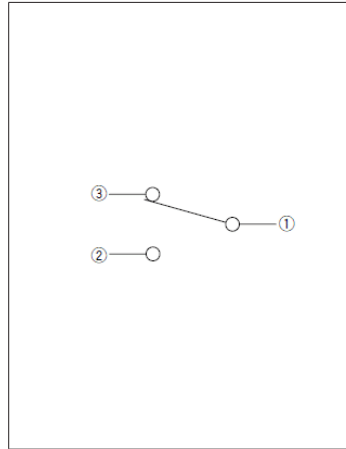

Drawing No.5

■ Dimensions

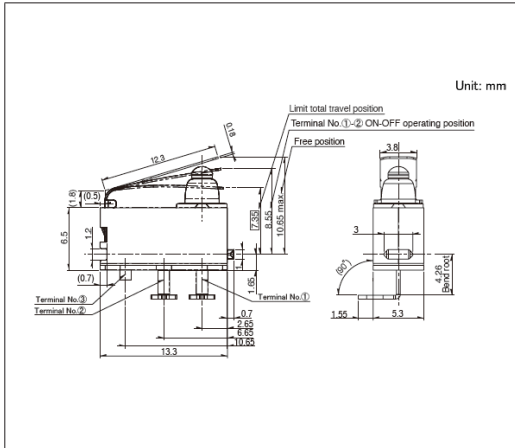

■ Circuit Diagram

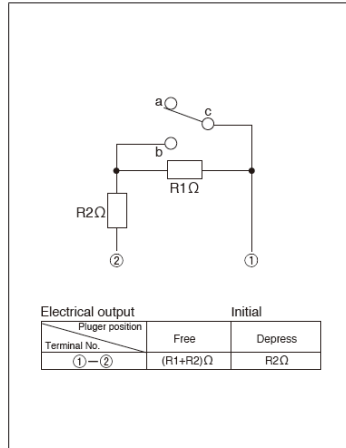

Please contact us for resistance specifications and rated power.

## Water-proof Type SPVQ7 Series

Low-profile type with a body height of 6.7mm.

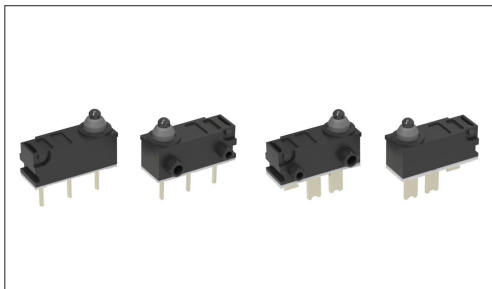

Automotive

Water-proof Type

Dust-proof Type

- Rating(max.)/(min.)(Resistive load):0.1A 12V DC/50 $\mu$ A 5V DC
- Contact resistance(Initial/After operating life):500m $\Omega$  max./1 $\Omega$  max.
- Operating life without load:300,000 cycles
- Operating life with load Rating(max.)(Resistive load):  
300,000 cycles 1 $\Omega$  max.

Applications:Energy\_Industrial:Robots, drones,Industrial equipment  
Home:Major home appliances  
Automotive:Hood Latch (Side/Rear/Door/Gear)

### Product List

Products No.	Poles	Positions	Operating force	Changeover timing	Operation part shape	Terminal type	Main body form	Dimensions (WxDxH) (mm)	Water-proof	Dust-proof	Automotive	Drawing No.
SPVQ710103	1	2	1 $\pm$ 0.5N	Non shorting	Push	For PC board	Boss - left side	5.4x14.7x6.7	●	●	●	1
SPVQ710203	1	2	1 $\pm$ 0.5N	Non shorting	Push	For PC board	Boss - right side	5.4x14.7x6.7	●	●	●	2
SPVQ710304	1	1	1 $\pm$ 0.5N	Non shorting	Push	For PC board	Boss - left side	5.4x14.7x6.7	●	●	●	3
SPVQ710404	1	1	1 $\pm$ 0.5N	Non shorting	Push	For PC board	Boss - right side	5.4x14.7x6.7	●	●	●	4
SPVQ740303	1	1	1 $\pm$ 0.5N	Non shorting	Push	For Lead	Boss - left side	5.4x14.7x6.7	●	●	●	5
SPVQ740403	1	1	1 $\pm$ 0.5N	Non shorting	Push	For Lead	Boss - right side	5.4x14.7x6.7	●	●	●	6
SPVQ740103	1	2	1 $\pm$ 0.5N	Non shorting	Push	For Lead	Boss - left side	5.4x14.7x6.7	●	●	●	7
SPVQ740203	1	2	1 $\pm$ 0.5N	Non shorting	Push	For Lead	Boss - right side	5.4x14.7x6.7	●	●	●	8

### Note

1. This catalog shows only outline specifications. When using the products, please obtain formal specifications for supply.
2. This unit cannot be used in water (IP6K7 rating, except for terminal).
3. Please place purchase orders per minimum order unit (integer).
4. This products can be used in vehicles.

Although these products are designed to perform over a wide operating temperature range, please ensure that you receive and read the formal delivery specifications before use.

### Packing Specifications

Tray

Number of packages(pcs.)		Export package measurements (mm)
1 case / Japan	1 case / export packing	
1,350	5,400	540 x 360 x 270

Water-proof Type  
SPVQ7 Series

Drawing No.1

■ Dimensions

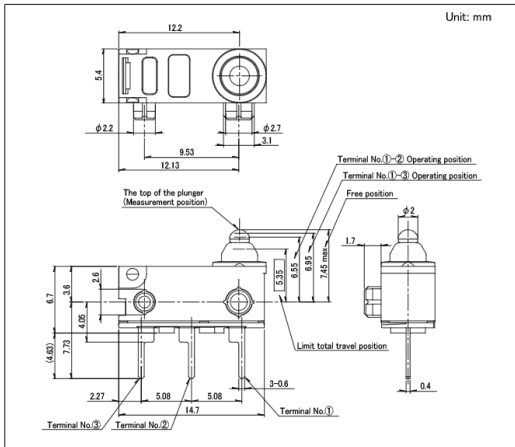

■ Circuit Diagram

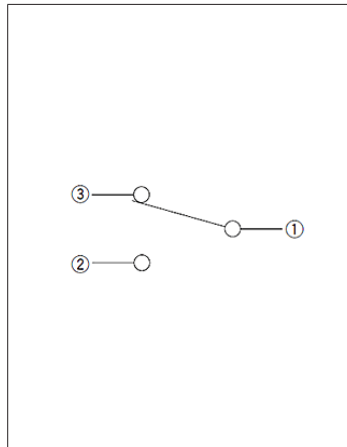

Drawing No.2

■ Dimensions

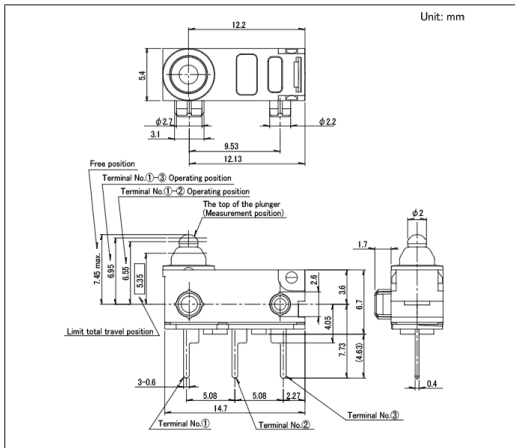

■ Circuit Diagram

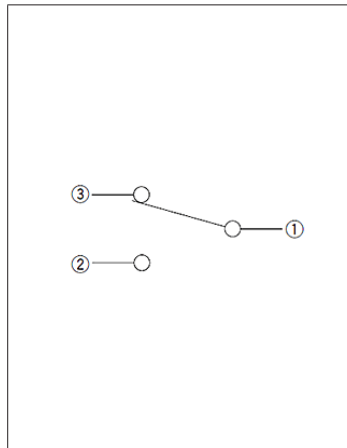

Drawing No.3

■ Dimensions

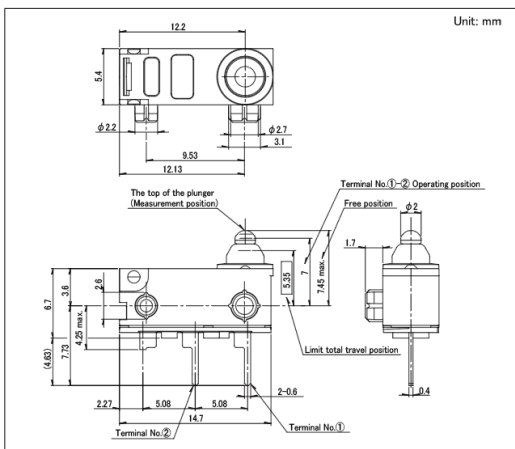

■ Circuit Diagram

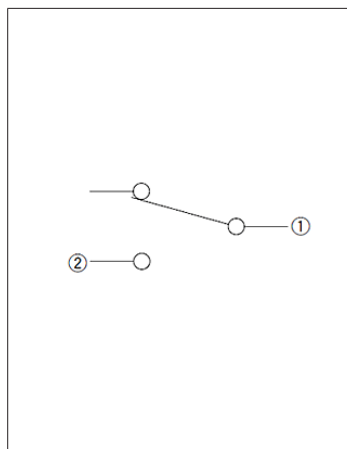

Water-proof Type  
SPVQ7 Series

Drawing No.4

■ Dimensions

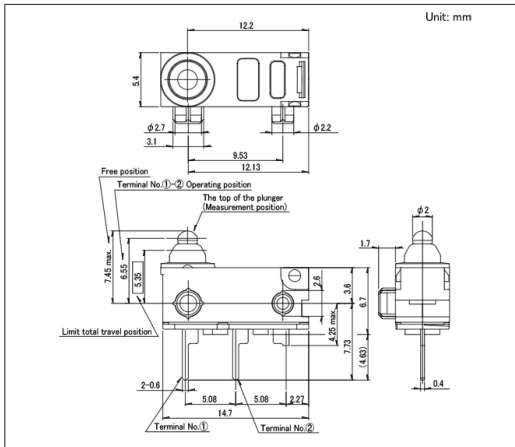

■ Circuit Diagram

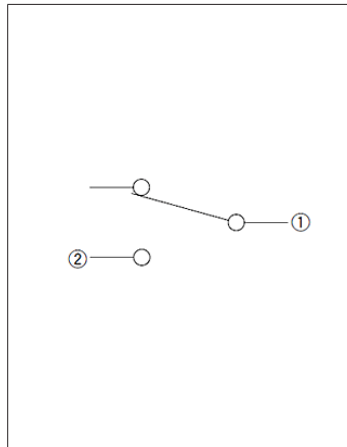

Drawing No.5

■ Dimensions

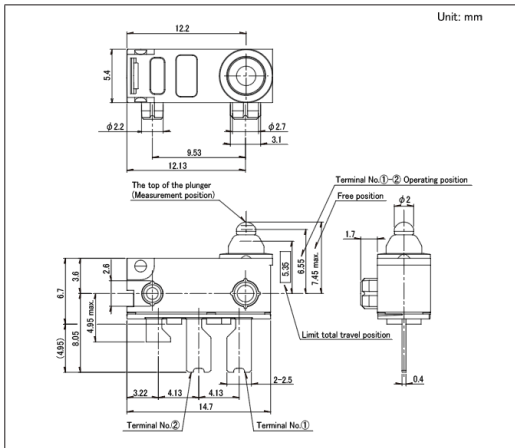

■ Circuit Diagram

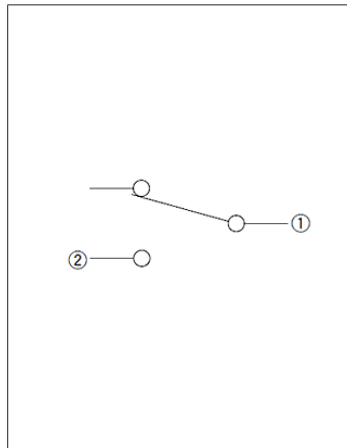

Drawing No.6

■ Dimensions

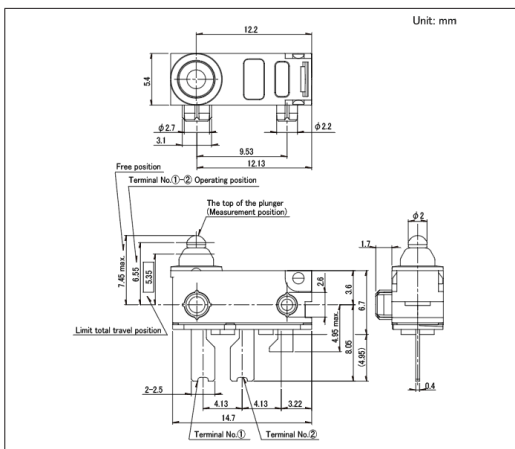

■ Circuit Diagram

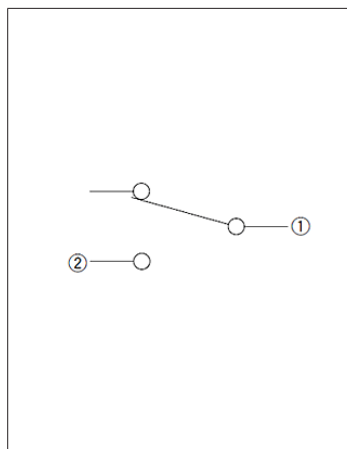

Water-proof Type  
SPVQ7 Series

Drawing No.7

■ Dimensions

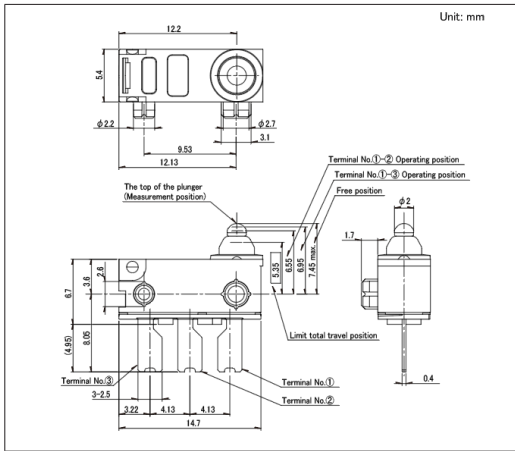

■ Circuit Diagram

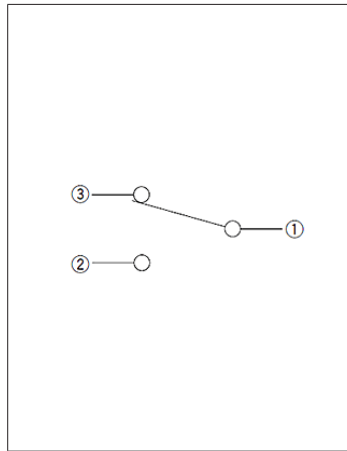

Drawing No.8

■ Dimensions

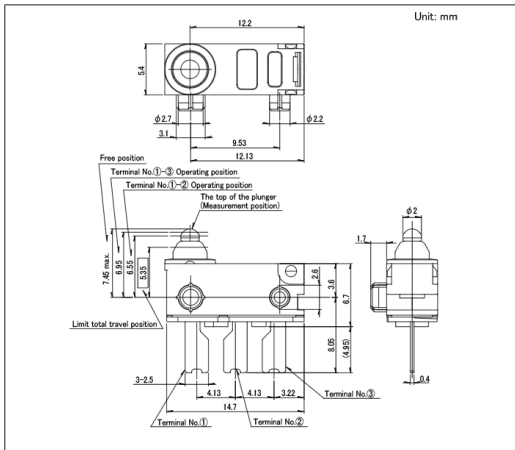

■ Circuit Diagram

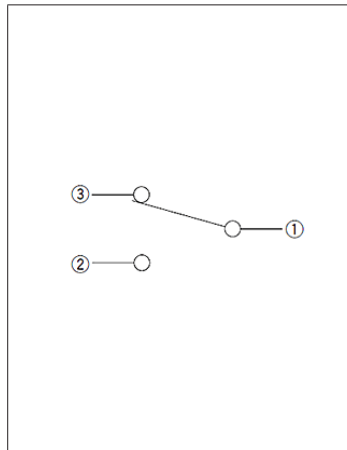

## Water-proof Type SPVQ8 Series

Offers a wide product variety with an industry-leading compact size of 8.3×5.3×7.0mm body dimensions.



Automotive



Water-proof Type



Dust-proof Type

- Rating(max.)/(min.)(Resistive load):0.1A 16V DC/50 $\mu$ A 5V DC
- Contact resistance(Initial/After operating life):500m $\Omega$  max./1 $\Omega$  max.
- Operating life without load:300,000 cycles
- Operating life with load Rating(max.)(Resistive load):  
300,000 cycles 1 $\Omega$  max.

Applications:Energy\_Industrial:Robots, drones,Industrial equipment  
Home:Major home appliances  
Automotive:Hood Latch (Side/Rear/Door/Gear)

### Product List

Products No.	Type	Poles	Positions	Operating force	Terminal type	Circuit	Main body form	Dimensions (W×D×H) (mm)	Water-proof	Dust-proof	Automotive	Drawing No.
SPVQ810102	Standard type	1	1	1±0.5N	For PC board	N/O	Boss - both sides	5.3×8.3×6.5	●	●	●	1
SPVQ810302		1	1	1±0.5N	Angle	N/O	Boss - single side	5.3×8.3×6.5	●	●	●	2
SPVQ810402		1	1	1±0.5N	Angle	N/O	Without boss	5.3×8.3×6.5	●	●	●	3
SPVQ810502		1	1	1±0.5N	For PC board	N/O	Without boss	5.3×8.3×6.5	●	●	●	4
SPVQ810602		1	1	1±0.5N	For PC board	N/O	Boss - single side	5.3×8.3×6.5	●	●	●	5
SPVQ810704		1	1	1±0.5N	For Lead	N/O	Boss - single side	5.3×8.3×6.5	●	●	●	6
SPVQ810802		1	1	1±0.5N	For Lead	N/O	Boss - both sides	5.3×8.3×6.5	●	●	●	7
SPVQ811006		1	1	1±0.5N	Press-fit (normal type)	N/O	Boss - single side	5.3×8.3×6.5	●	●	●	8
SPVQ820102		1	1	1±0.5N	For PC board	N/C	Boss - both sides	5.3×8.3×6.5	●	●	●	9
SPVQ820302		1	1	1±0.5N	Angle	N/C	Boss - single side	5.3×8.3×6.5	●	●	●	10
SPVQ820402		1	1	1±0.5N	Angle	N/C	Without boss	5.3×8.3×6.5	●	●	●	11
SPVQ820502		1	1	1±0.5N	For PC board	N/C	Without boss	5.3×8.3×6.5	●	●	●	12
SPVQ820602		1	1	1±0.5N	For PC board	N/C	Boss - single side	5.3×8.3×6.5	●	●	●	13
SPVQ820705		1	1	1±0.5N	For Lead	N/C	Boss - single side	5.3×8.3×6.5	●	●	●	14
SPVQ820802		1	1	1±0.5N	For Lead	N/C	Boss - both sides	5.3×8.3×6.5	●	●	●	15
SPVQ821006		1	1	1±0.5N	Press-fit (normal type)	N/C	Boss - single side	5.3×8.3×6.5	●	●	●	16
SPVQ850101		1	1	1±0.5N	With wire (Downwards)	N/O	Boss - single side	5.3×8.3×6.5	●	●	●	17
SPVQ850201		1	1	1±0.5N	With wire (Downwards)	N/O	Boss - both sides	5.3×8.3×6.5	●	●	●	18
SPVQ850301		1	1	1±0.5N	With wire (Left side)	N/O	Boss - single side	5.3×8.3×6.5	●	●	●	19
SPVQ850501		1	1	1±0.5N	With wire (from side)	N/O	Boss - both sides	5.3×8.3×6.5	●	●	●	20
SPVQ860101		1	1	1±0.5N	With wire (Downwards)	N/C	Boss - single side	5.3×8.3×6.5	●	●	●	21
SPVQ860200		1	1	1±0.5N	With wire (Downwards)	N/C	Boss - both sides	5.3×8.3×6.5	●	●	●	22
SPVQ860301		1	1	1±0.5N	With wire (Left side)	N/C	Boss - single side	5.3×8.3×6.5	●	●	●	23
SPVQ860500		1	1	1±0.5N	With wire (from side)	N/C	Boss - both sides	5.3×8.3×6.5	●	●	●	24

Water-proof Type  
SPVQ8 Series

Products No.	Type	Poles	Positions	Operating force	Terminal type	Circuit	Main body form	Dimensions (W×D×H) (mm)	Water-proof	Dust-proof	Automotive	Drawing No.
SPVQ811502	Standard type	1	1	1±0.5N	Press-fit (Short type)	N/O	Boss - single side	5.3×8.3×6.5	●	●	●	25
SPVQ821500		1	1	1±0.5N	Press-fit (Short type)	N/C	Boss - single side	5.3×8.3×6.5	●	●	●	26
SPVQ812600		1	1	3N max.	For Lead	N/O	Boss - right side	5.3×8.3×6.5	●	●	●	27
SPVQ812400		1	1	3N max.	Press-fit (normal type)	N/O	Boss - right side	5.3×8.3×6.5	●	●	●	28
SPVQ812200		1	1	3N max.	Press-fit (Short type)	N/O	Boss - right side	5.3×8.3×6.5	●	●	●	29
SPVQ812700		1	1	3N max.	For Lead	N/O	Boss - left side	5.3×8.3×6.5	●	●	●	30
SPVQ812500		1	1	3N max.	Press-fit (normal type)	N/O	Boss - left side	5.3×8.3×6.5	●	●	●	31
SPVQ812300		1	1	3N max.	Press-fit (Short type)	N/O	Boss - left side	5.3×8.3×6.5	●	●	●	32
SPVQ822500		1	1	3N max.	For Lead	N/C	Boss - right side	5.3×8.3×6.5	●	●	●	33
SPVQ822300		1	1	3N max.	Press-fit (normal type)	N/C	Boss - right side	5.3×8.3×6.5	●	●	●	34
SPVQ822100		1	1	3N max.	Press-fit (Short type)	N/C	Boss - right side	5.3×8.3×6.5	●	●	●	35
SPVQ822600		1	1	3N max.	For Lead	N/C	Boss - left side	5.3×8.3×6.5	●	●	●	36
SPVQ822400		1	1	3N max.	Press-fit (normal type)	N/C	Boss - left side	5.3×8.3×6.5	●	●	●	37
SPVQ822200		1	1	3N max.	Press-fit (Short type)	N/C	Boss - left side	5.3×8.3×6.5	●	●	●	38
SPVQ830102		Long life type	1	1	1±0.5N	For PC board	N/O	Boss - both sides	5.3×8.3×6.5	●	●	●
SPVQ830302	1		1	1±0.5N	Angle	N/O	Boss - single side	5.3×8.3×6.5	●	●	●	40
SPVQ830402	1		1	1±0.5N	Angle	N/O	Without boss	5.3×8.3×6.5	●	●	●	41
SPVQ830502	1		1	1±0.5N	For PC board	N/O	Without boss	5.3×8.3×6.5	●	●	●	42
SPVQ830602	1		1	1±0.5N	For PC board	N/O	Boss - single side	5.3×8.3×6.5	●	●	●	43
SPVQ830702	1		1	1±0.5N	For Lead	N/O	Boss - single side	5.3×8.3×6.5	●	●	●	44
SPVQ830802	1		1	1±0.5N	For Lead	N/O	Boss - both sides	5.3×8.3×6.5	●	●	●	45
SPVQ831002	1		1	1±0.5N	Press-fit (normal type)	N/O	Boss - single side	5.3×8.3×6.5	●	●	●	46
SPVQ8R02	Normal type With internal resistor type	1	1	1±0.5N	For PC board	—	Boss - single side	5.3×8.3×6.5	●	●	●	47
SPVQ8R06		1	1	1±0.5N	Press-fit (normal type)	—	Boss - single side	5.3×8.3×6.5	●	●	●	48
SPVQ8R01		1	1	1±0.5N	Press-fit (Short type)	—	Boss - single side	5.3×8.3×6.5	●	●	●	49

 Note

1. This catalog shows only outline specifications. When using the products, please obtain formal specifications for supply.
2. Unless specified, the length of the lead wire is 250mm. Color is either red or black. For length modification, please contact us.
3. Please specify circuits (N.O. or N.C.) for wired (side) types. Unless specified, the circuit will apply N.O.
4. This unit cannot be used in water (IP6K7 rating, except for terminal).
5. Please place purchase orders per minimum order unit (integer).
6. This products can be used in vehicles.

Although these products are designed to perform over a wide operating temperature range, please ensure that you receive and read the formal delivery specifications before use.

Water-proof Type  
**SPVQ8 Series**

■ Packing Specifications

Tray

Products No.	Number of packages(pcs.)		Export package measurements (mm)
	1 case / Japan	1 case / export packing	
SPVQ810102 SPVQ810302 SPVQ810402 SPVQ810502 SPVQ810602 SPVQ810704 SPVQ810802 SPVQ811006 SPVQ820102 SPVQ820302 SPVQ820402 SPVQ820502 SPVQ820602 SPVQ820705 SPVQ820802 SPVQ821006 SPVQ811502 SPVQ821500 SPVQ830102 SPVQ830302 SPVQ830402 SPVQ830502 SPVQ830602 SPVQ830702 SPVQ830802 SPVQ831002 SPVQ8R02 SPVQ8R06 SPVQ8R01	1,755	7,020	540 x 360 x 270
SPVQ812600 SPVQ812400 SPVQ812200 SPVQ812700 SPVQ812500 SPVQ812300 SPVQ822500 SPVQ822300 SPVQ822100 SPVQ822600 SPVQ822400 SPVQ822200	1,080	4,320	540 x 360 x 270

Bulk

Products No.	Number of packages(pcs.)		Export package measurements (mm)
	1 case / Japan	1 case / export packing	
SPVQ850101 SPVQ850201 SPVQ850301 SPVQ850501 SPVQ860101 SPVQ860200 SPVQ860301 SPVQ860500	400	1,600	555 x 375 x 223

**Drawing No. 1**

■ Dimensions

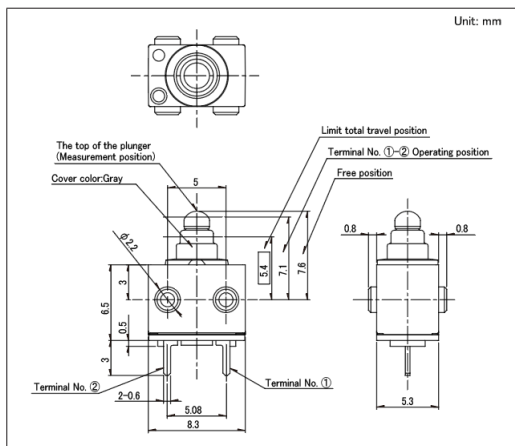

■ Circuit Diagram

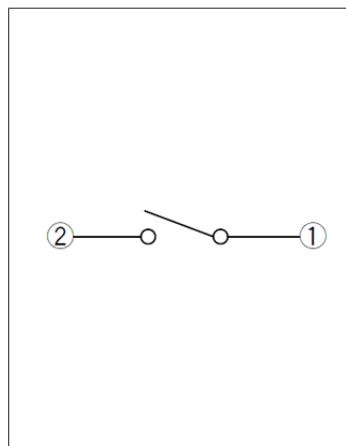

Water-proof Type  
SPVQ8 Series

Drawing No.2

■ Dimensions

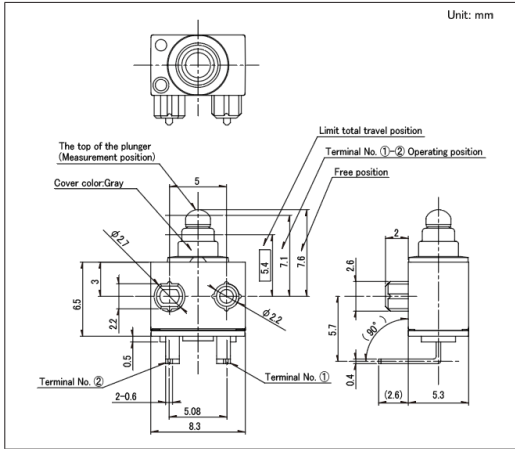

■ Circuit Diagram

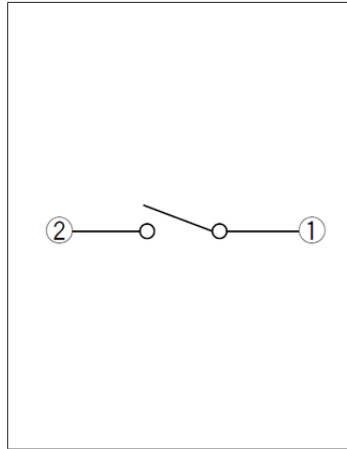

Drawing No.3

■ Dimensions

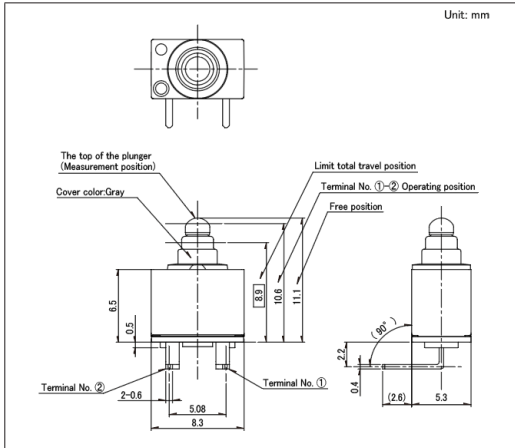

■ Circuit Diagram

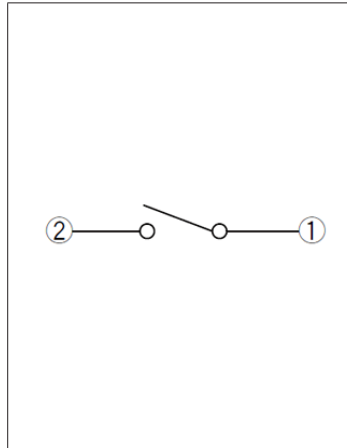

Drawing No.4

■ Dimensions

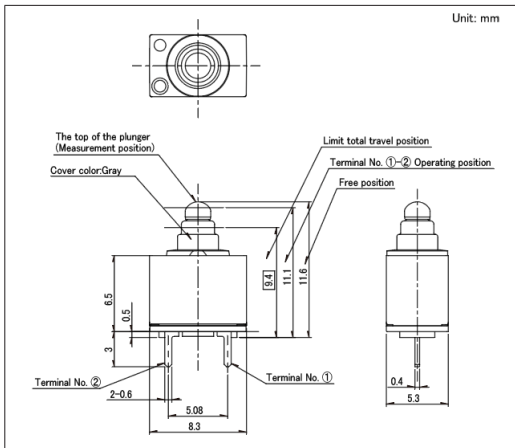

■ Circuit Diagram

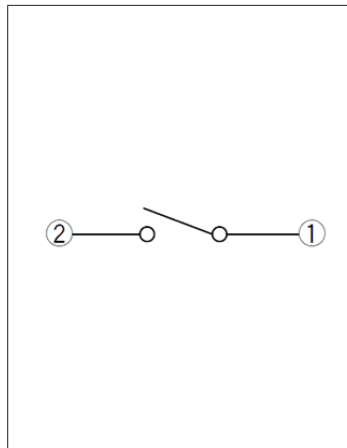

Water-proof Type  
SPVQ8 Series

Drawing No.5

■ Dimensions

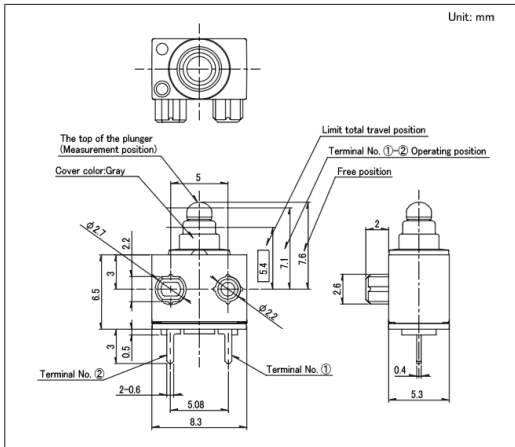

■ Circuit Diagram

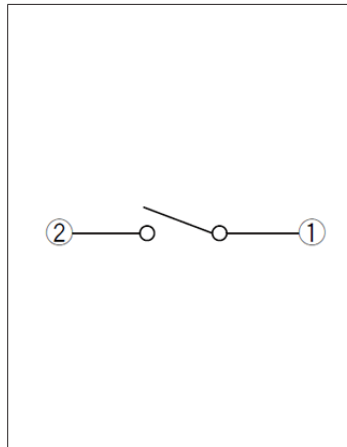

Drawing No.6

■ Dimensions

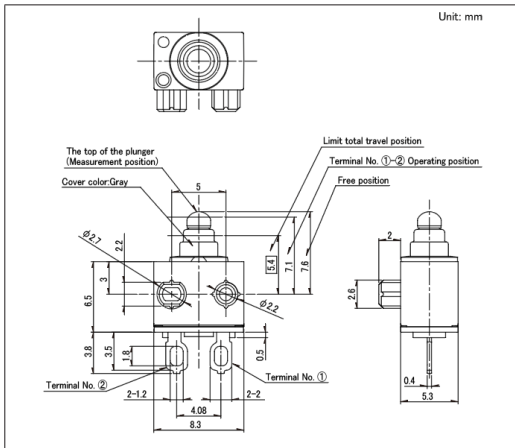

■ Circuit Diagram

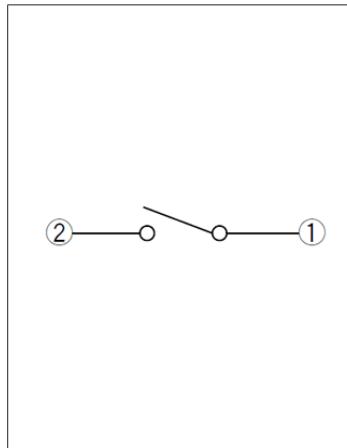

Drawing No.7

■ Dimensions

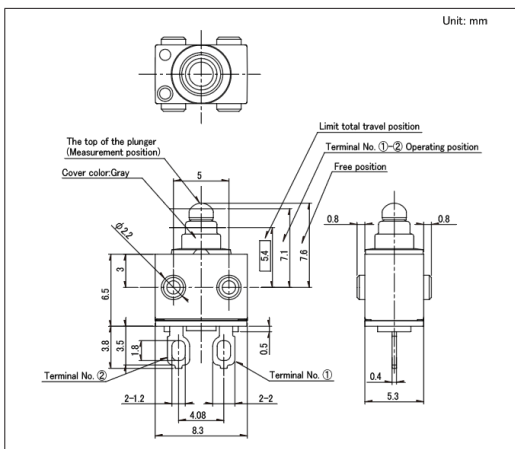

■ Circuit Diagram

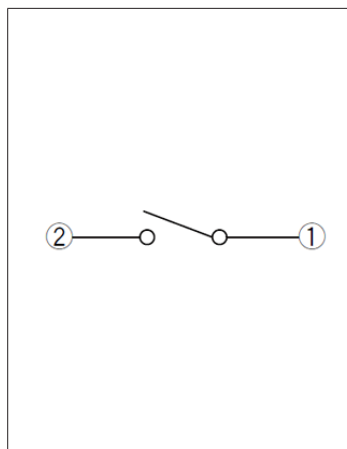

Water-proof Type  
SPVQ8 Series

Drawing No.8

■ Dimensions

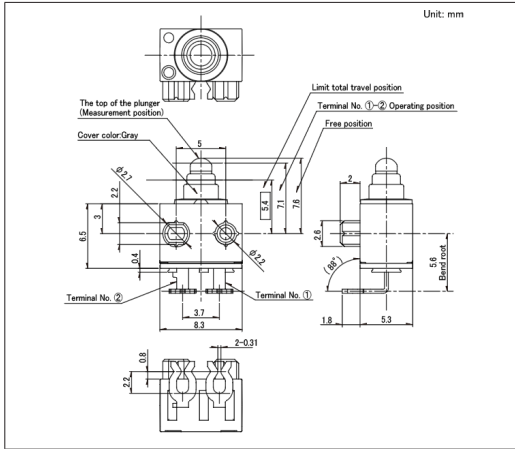

■ Circuit Diagram

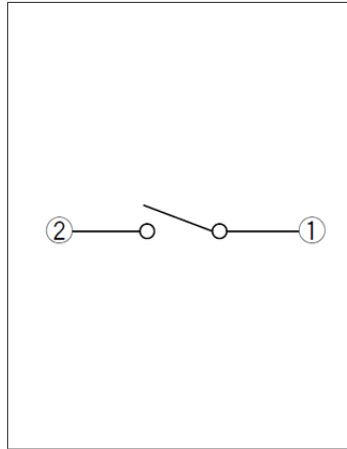

Drawing No.9

■ Dimensions

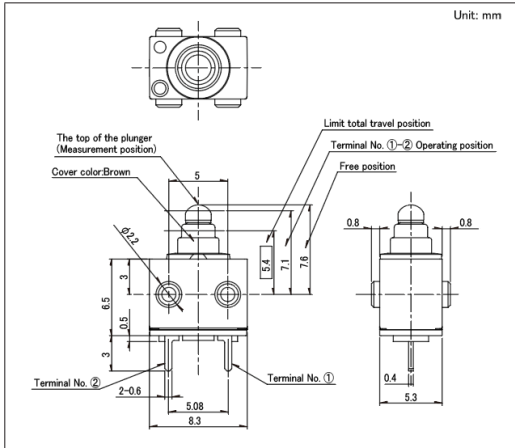

■ Circuit Diagram

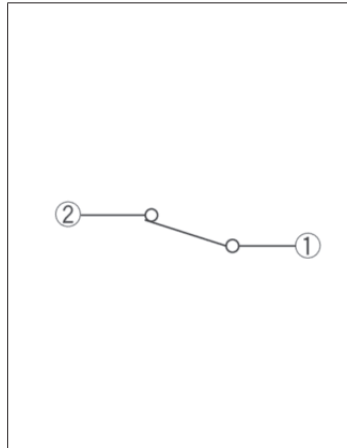

Drawing No.10

■ Dimensions

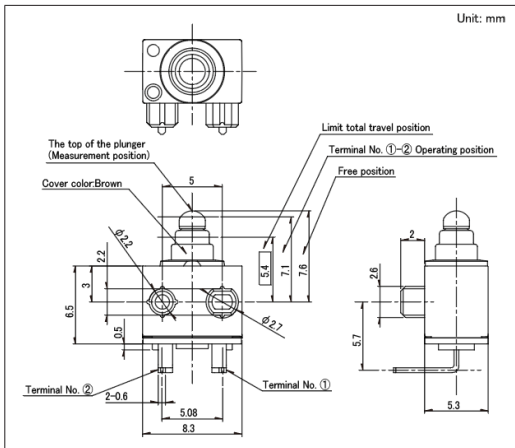

■ Circuit Diagram

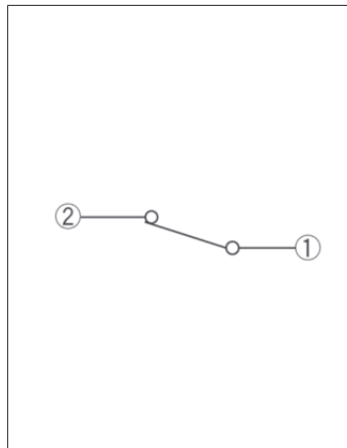

Water-proof Type  
SPVQ8 Series

Drawing No.11

■ Dimensions

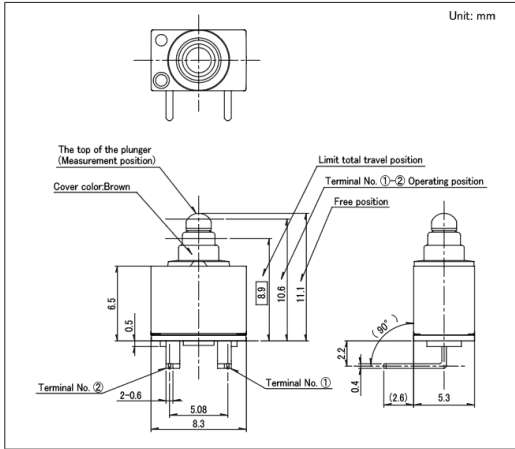

■ Circuit Diagram

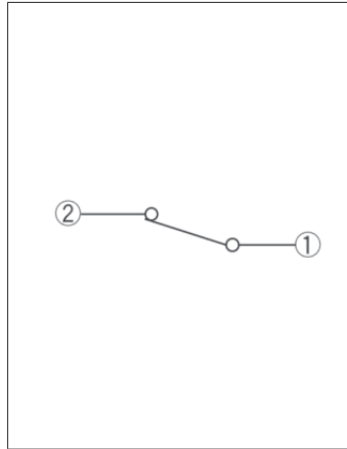

Drawing No.12

■ Dimensions

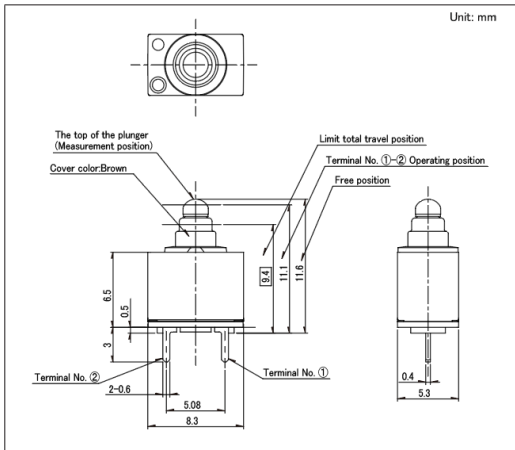

■ Circuit Diagram

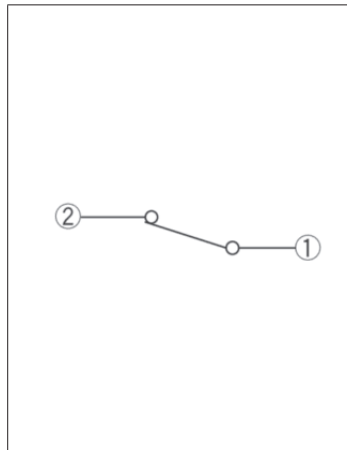

Drawing No.13

■ Dimensions

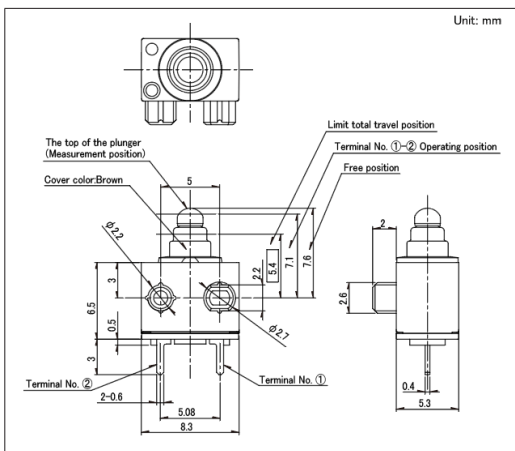

■ Circuit Diagram

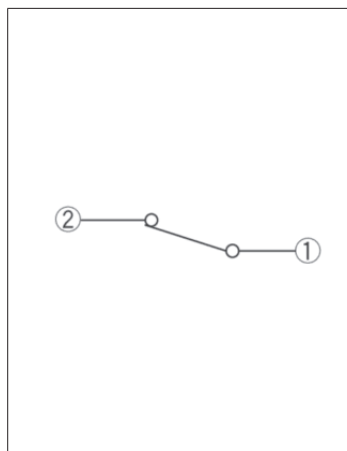

Water-proof Type  
SPVQ8 Series

Drawing No.14

■ Dimensions

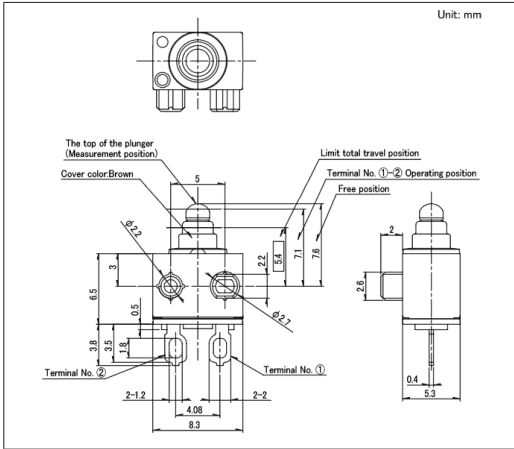

■ Circuit Diagram

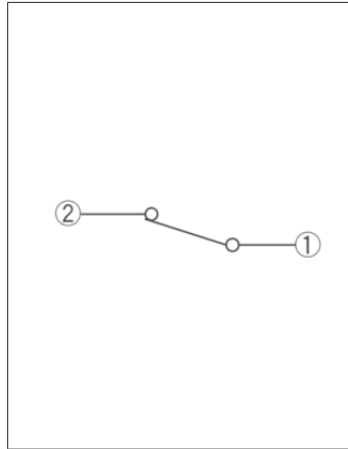

Drawing No.15

■ Dimensions

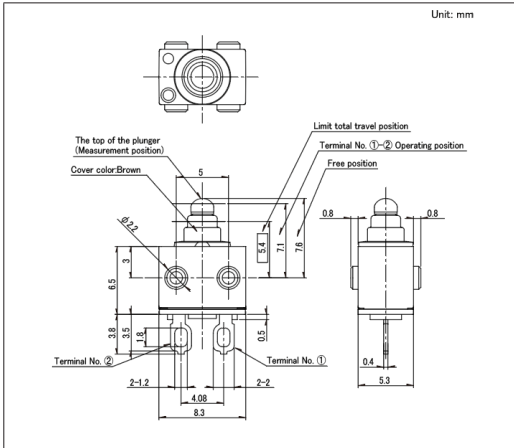

■ Circuit Diagram

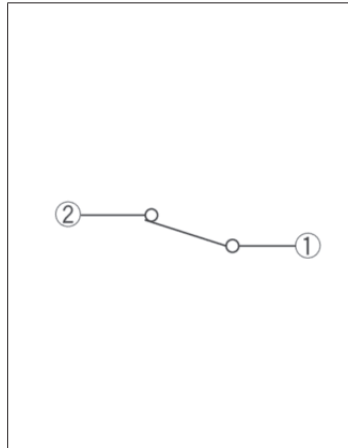

Drawing No.16

■ Dimensions

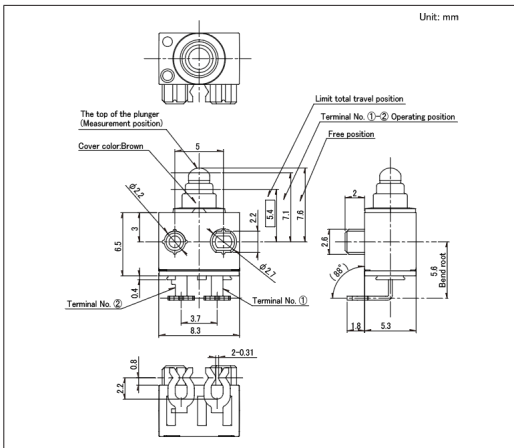

■ Circuit Diagram

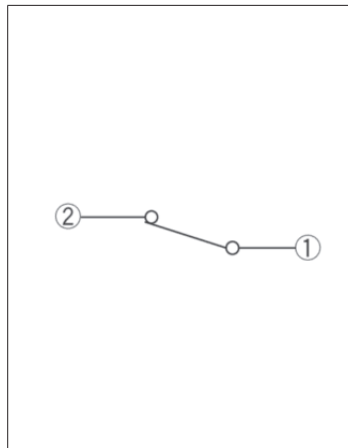

Water-proof Type  
SPVQ8 Series

Drawing No.17

■ Dimensions

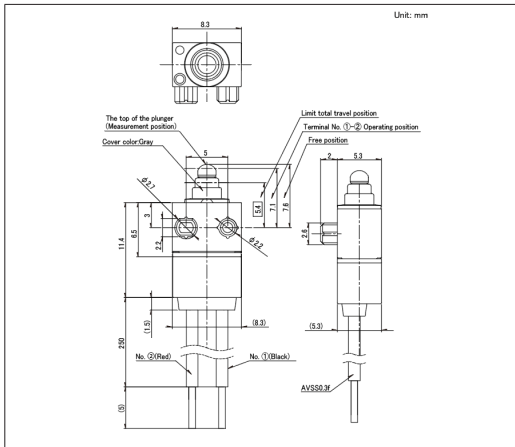

■ Circuit Diagram

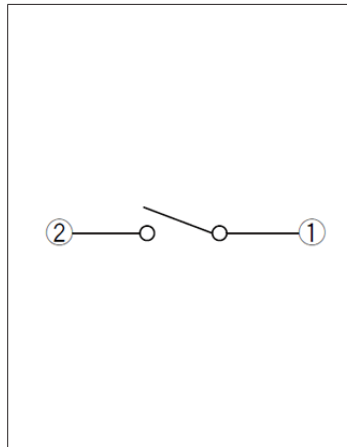

Drawing No.18

■ Dimensions

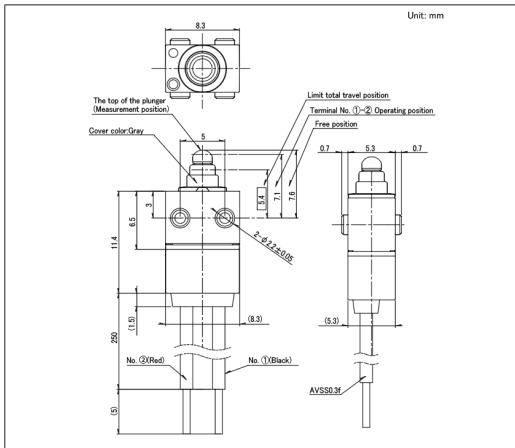

■ Circuit Diagram

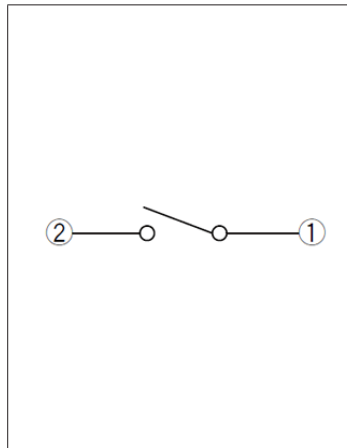

Drawing No.19

■ Dimensions

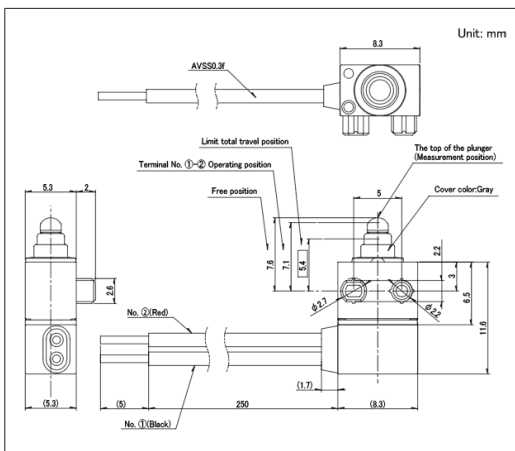

■ Circuit Diagram

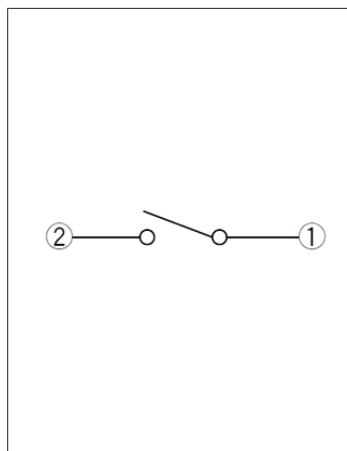

Water-proof Type  
SPVQ8 Series

Drawing No.20

■ Dimensions

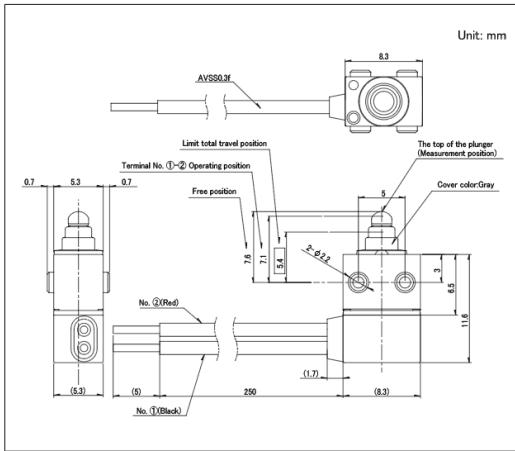

■ Circuit Diagram

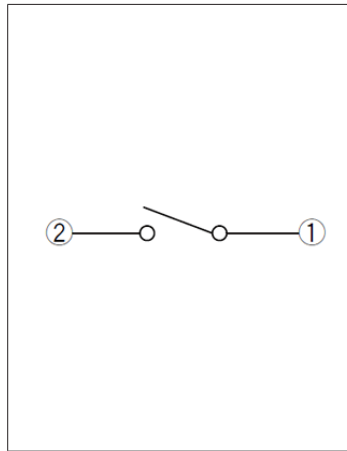

Drawing No.21

■ Dimensions

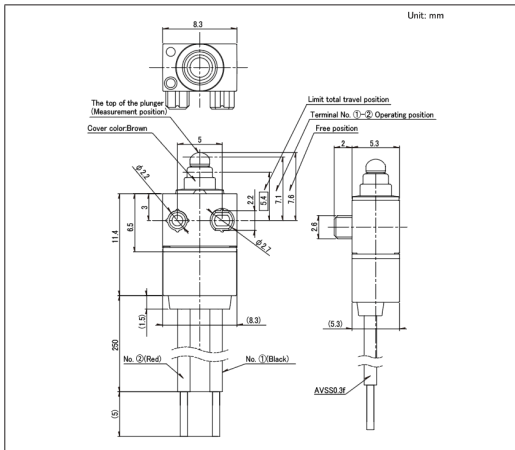

■ Circuit Diagram

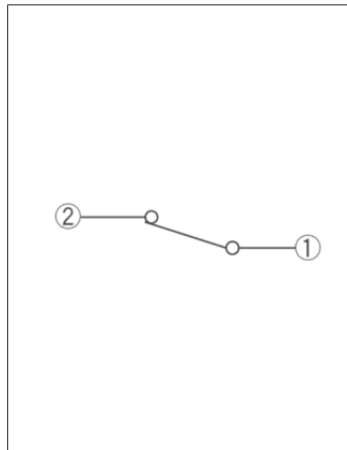

Drawing No.22

■ Dimensions

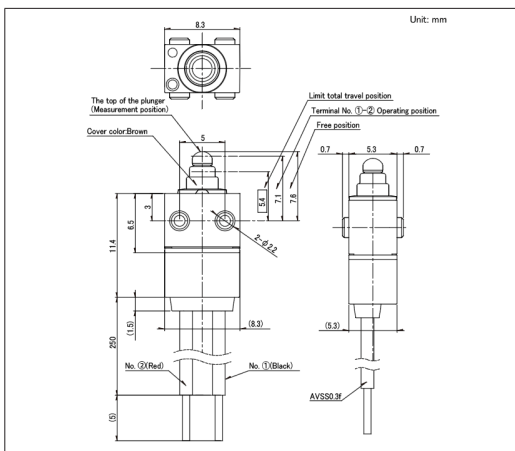

■ Circuit Diagram

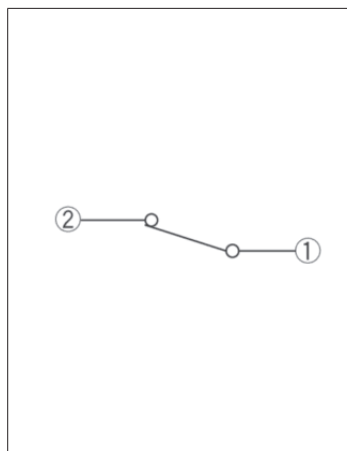



# Water-proof Type SPVQ8 Series

## Drawing No.26

### ■ Dimensions

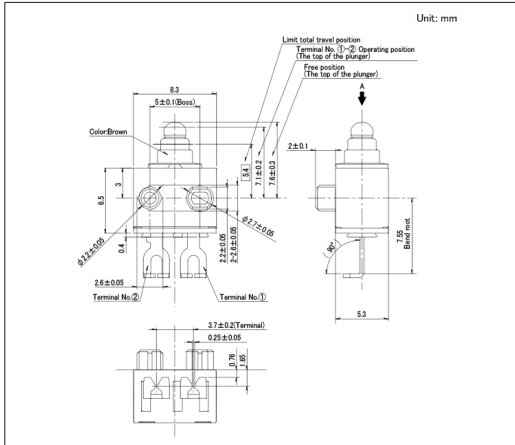

### ■ Circuit Diagram

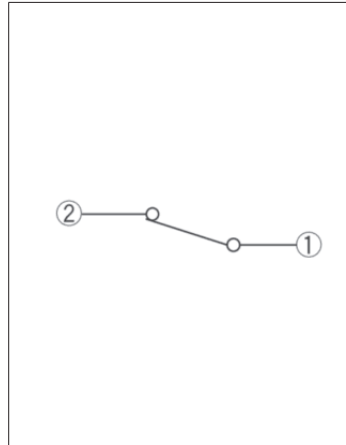

## Drawing No.27

### ■ Dimensions

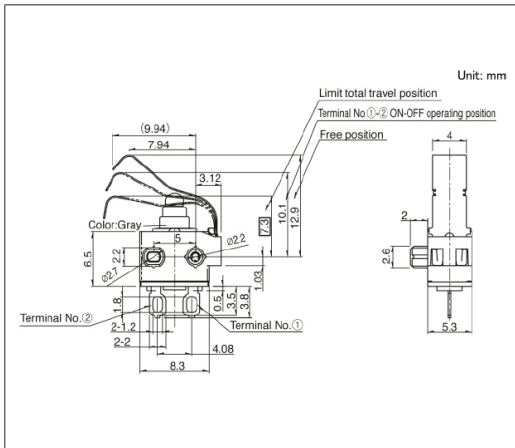

### ■ Circuit Diagram

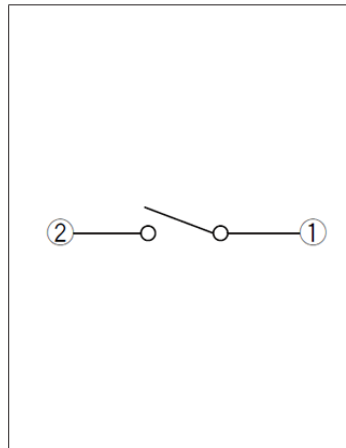

## Drawing No.28

### ■ Dimensions

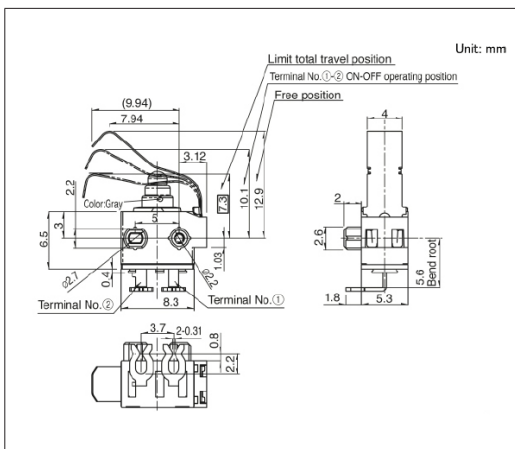

### ■ Circuit Diagram

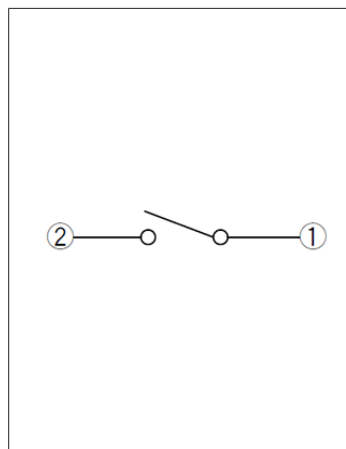





Switches **Detector Switches**  
**Water-proof Type**  
**SPVQ8 Series**

**Drawing No.35**

■ Dimensions

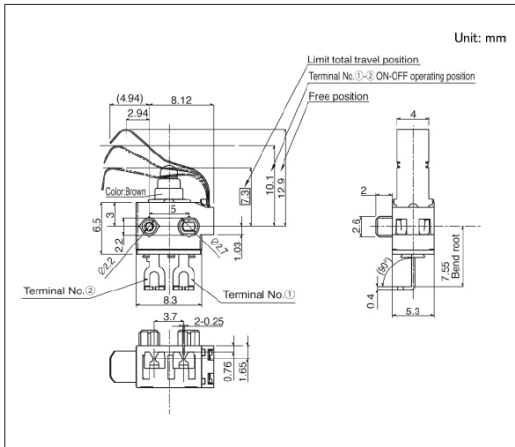

■ Circuit Diagram

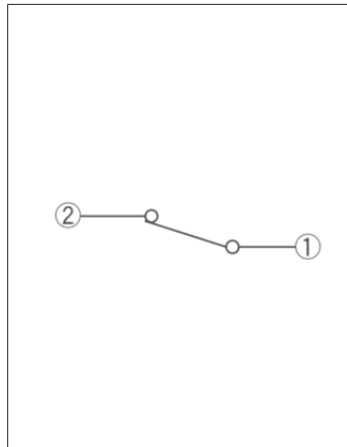

**Drawing No.36**

■ Dimensions

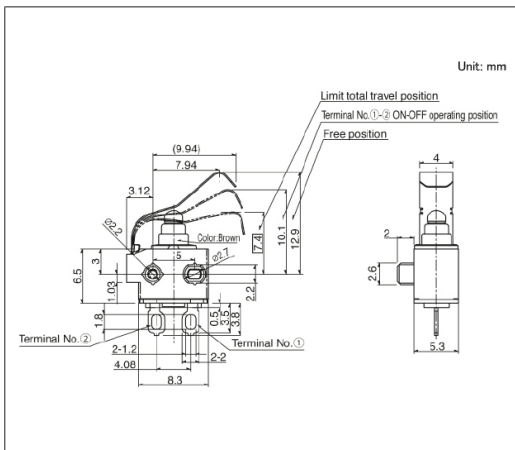

■ Circuit Diagram

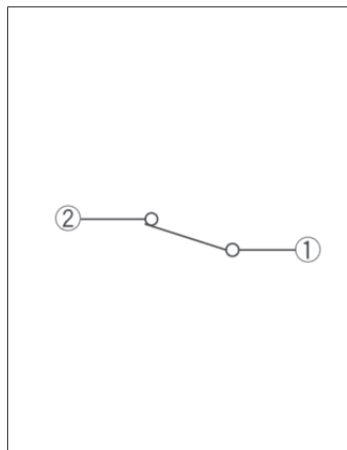

**Drawing No.37**

■ Dimensions

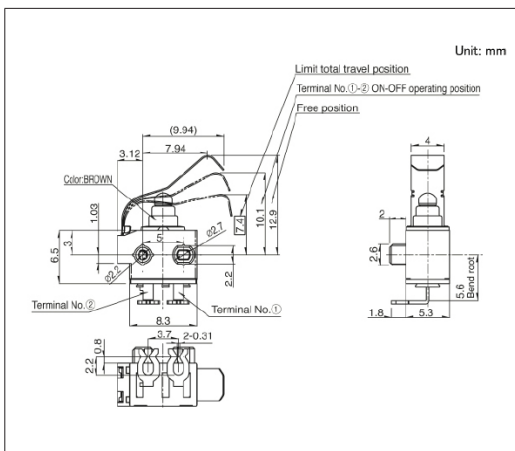

■ Circuit Diagram

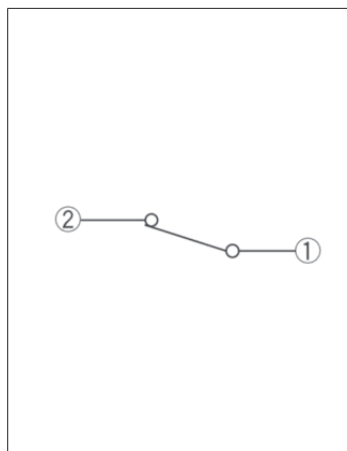



Water-proof Type  
SPVQ8 Series

Drawing No.41

■ Dimensions

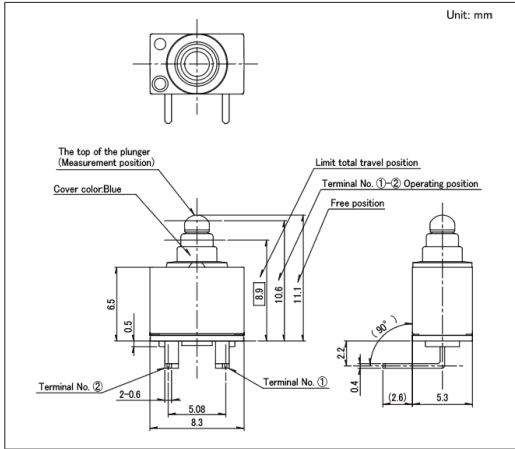

■ Circuit Diagram

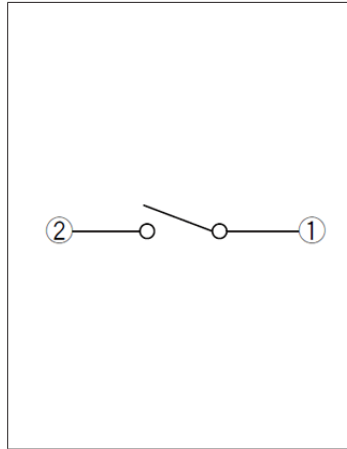

Drawing No.42

■ Dimensions

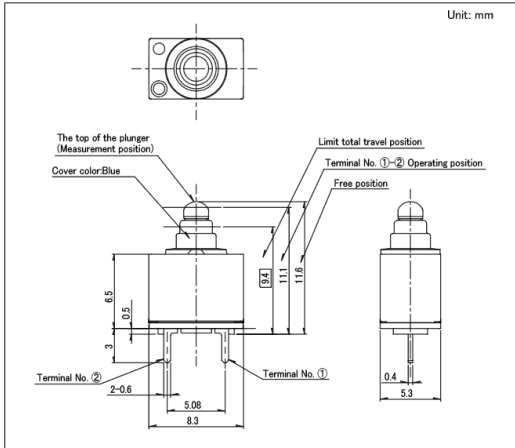

■ Circuit Diagram

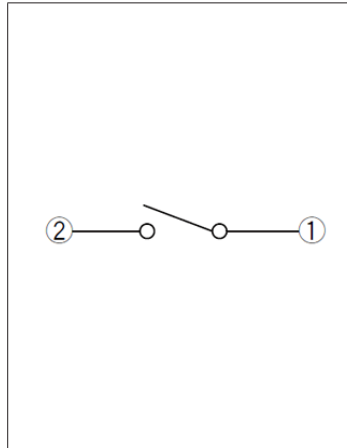

Drawing No.43

■ Dimensions

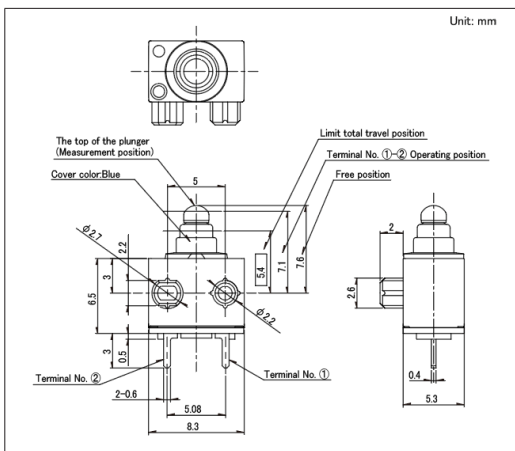

■ Circuit Diagram

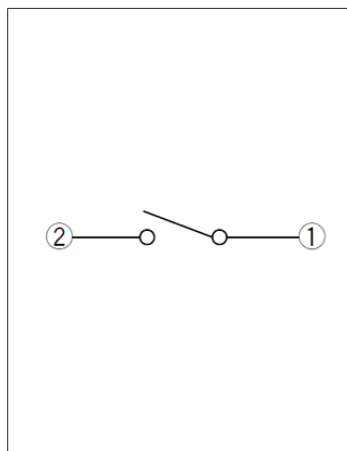



Water-proof Type  
SPVQ8 Series

Drawing No.47

■ Dimensions

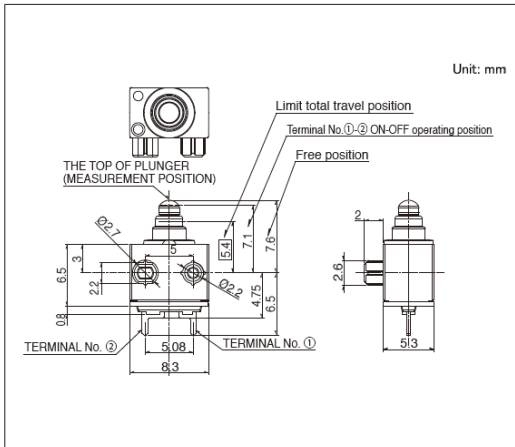

■ Circuit Diagram

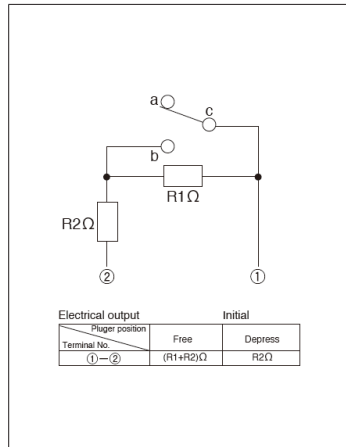

Please contact us for resistance specifications and rated power.

Drawing No.48

■ Dimensions

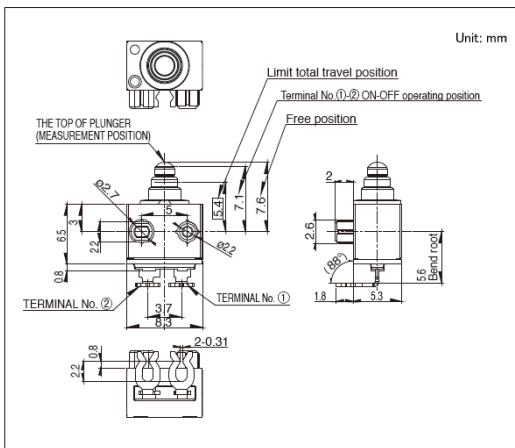

■ Circuit Diagram

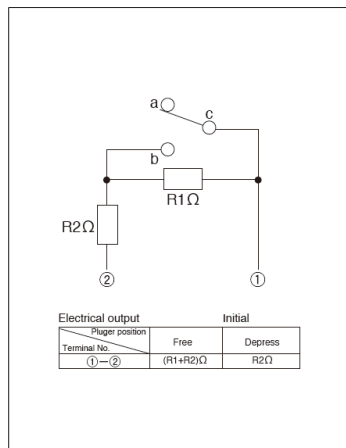

Please contact us for resistance specifications and rated power.

Drawing No.49

■ Dimensions

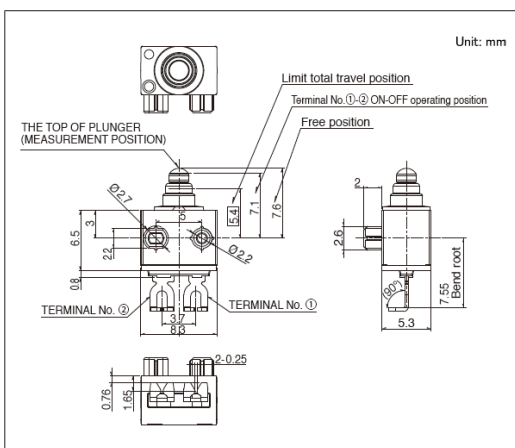

■ Circuit Diagram

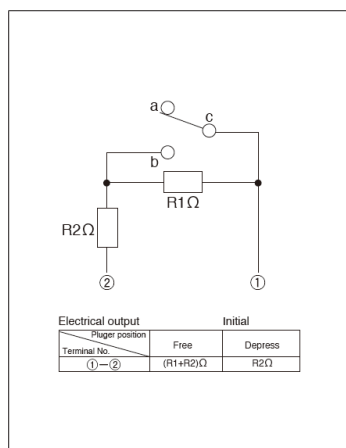

Please contact us for resistance specifications and rated power.

Switches **Detector Switches**

Water-proof Type  
**SPVQ8H Series**

Enhanced robustness with a wire pull strength of 110N.

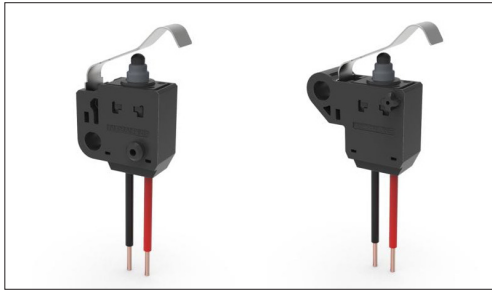

- Automotive
- Water-proof Type
- Dust-proof Type

- Rating(max.)/(min.)(Resistive load):0.1A 16V DC/50μA 5V DC
- Contact resistance(Initial/After operating life):500mΩ max./1Ω max.
- Operating life without load:100,000cycles
- Operating life with load Rating(max.)(Resistive load):  
100,000cycles 1Ω max.

Applications:Energy\_Industrial:Robots, drones,Industrial equipment  
Home:Major home appliances  
Automotive:Hood Latch (Side/Rear/Door/Gear)

■ Product List

Products No.	Poles	Positions	Operating force	Operation part shape	Terminal type	Circuit	Main body form	Dimensions (W×D×H) (mm)	Water-proof	Dust-proof	Automotive	Drawing No.
SPVQ8H0100	1	1	4.7N max.	Actuator	With wire (Downwards)	N/O	With a screw hole (Type A)	6,45×14,8×14,5	●	●	●	1
SPVQ8H0200	1	1	4.7N max.	Actuator	With wire (Downwards)	N/O	With a screw hole (Type B)	6,45×17,95×14,5	●	●	●	2

Note

1. This catalog shows only outline specifications. When using the products, please obtain formal specifications for supply.
2. Unless specified, the length of the lead wire is 250mm. Color is either red or black. For length modification, please contact us.
3. Product with wire will be build-to-order.
4. This unit cannot be used in water (IP6K7 rating, except for terminal).
5. Place your purchase order in N minimum package units (N: integer).
6. This products can be used in vehicles.  
Although these products are designed to perform over a wide operating temperature range, please ensure that you receive and read the formal delivery specifications before use.

■ Packing Specifications

Bulk

Number of packages (pcs.)		Export package measurements (mm)
1 case / Japan	1 case / export packing	
300	300	360 x 360 x 290

**Drawing No.1**

■ Dimensions

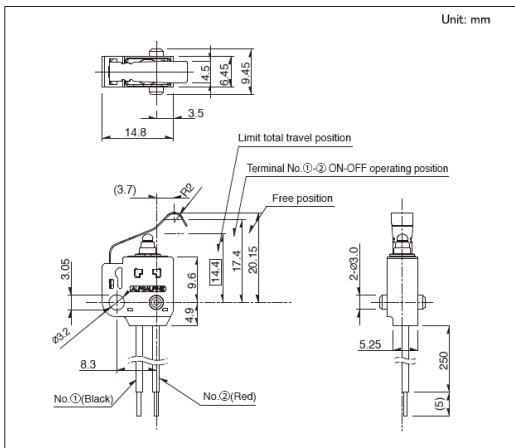

■ Circuit Diagram

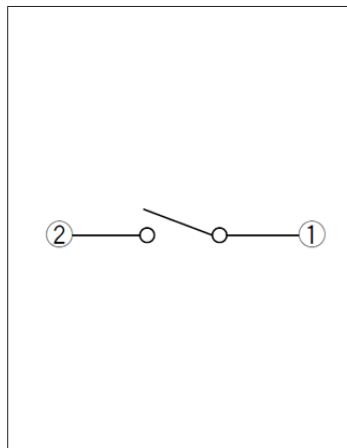

# Water-proof Type SPVQ8H Series

## Drawing No.2

### ■ Dimensions

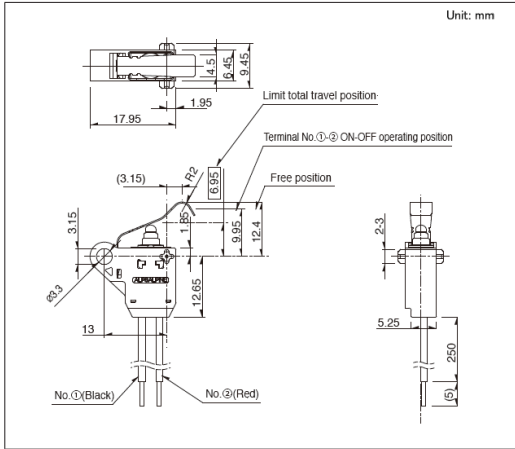

### ■ Circuit Diagram

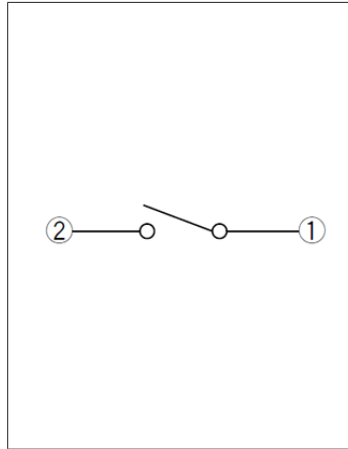



## Water-proof Type SPVQA Series

Supports solderless connection with fork terminals.

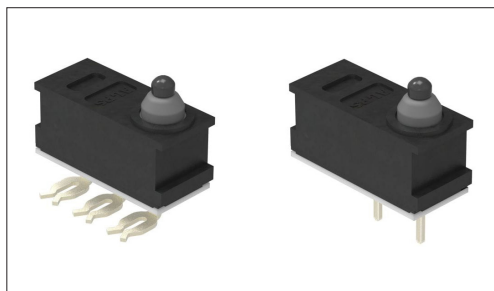

Automotive

Water-proof Type

Dust-proof Type

- Rating(max.)/(min.)(Resistive load):0.1 A 12V DC/50 $\mu$ A 5V DC
- Contact resistance(Initial/After operating life):500m $\Omega$  max./1 $\Omega$  max.
- Operating life without load:300,000 cycles
- Operating life with load Rating(max.)(Resistive load):  
300,000 cycles 1 $\Omega$  max.

Applications:Home:Major home appliances  
Automotive:Hood Latch (Side/Rear/Door/Gear)

### Product List

Products No.	Poles	Positions	Operating force	Changeover timing	Operation part shape	Terminal type	Main body form	Dimensions (W×D×H) (mm)	Water-proof	Dust-proof	Automotive	Drawing No.
SPVQA10103	1	1	1 $\pm$ 0.5N	Non shorting	Push	Press-fit (Without terminal No.3)	Without boss L type	6.4×15.2×7.95	●	●	●	1
SPVQA10203	1	1	1 $\pm$ 0.5N	Non shorting	Push	Press-fit (Without terminal No.3)	Without boss R type	6.4×15.2×7.95	●	●	●	2
SPVQA10302	1	1	1 $\pm$ 0.5N	Non shorting	Push	Press-fit (Without terminal No.2)	Without boss L type	6.4×15.2×7.95	●	●	●	3
SPVQA10402	1	1	1 $\pm$ 0.5N	Non shorting	Push	Press-fit (Without terminal No.2)	Without boss R type	6.4×15.2×7.95	●	●	●	4
SPVQA10504	1	2	1 $\pm$ 0.5N	Non shorting	Push	Press-fit	Without boss L type	6.4×15.2×7.95	●	●	●	5
SPVQA10604	1	2	1 $\pm$ 0.5N	Non shorting	Push	Press-fit	Without boss R type	6.4×15.2×7.95	●	●	●	6
SPVQA20103	1	1	1 $\pm$ 0.5N	Non shorting	Push	For PC board (Without terminal No.3)	Without boss	6.4×15.2×7.95	●	●	●	7
SPVQA20203	1	2	1 $\pm$ 0.5N	Non shorting	Push	For PC board	Without boss	6.4×15.2×7.95	●	●	●	8

### Note

1. This catalog shows only outline specifications. When using the products, please obtain formal specifications for supply.
2. This unit cannot be used in water (IP6K7 rating, except for terminal).
3. Please place purchase orders per minimum order unit (integer).
4. This products can be used in vehicles.  
Although these products are designed to perform over a wide operating temperature range, please ensure that you receive and read the formal delivery specifications before use.

### Packing Specifications

Tray

Number of packages(pcs.)		Export package measurements (mm)
1 case / Japan	1 case / export packing	
1,200	4,800	540 x 360 x 270

# Water-proof Type SPVQA Series

## Drawing No.1

### ■ Dimensions

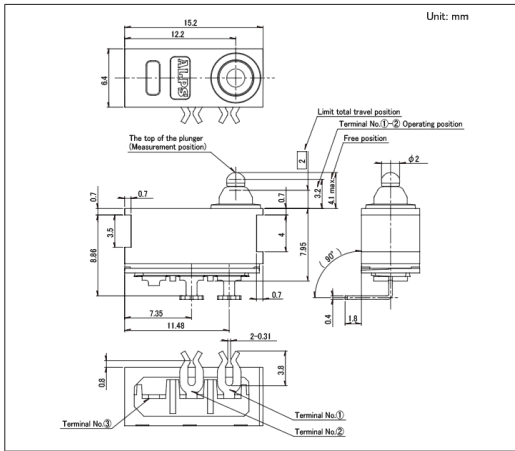

### ■ Circuit Diagram

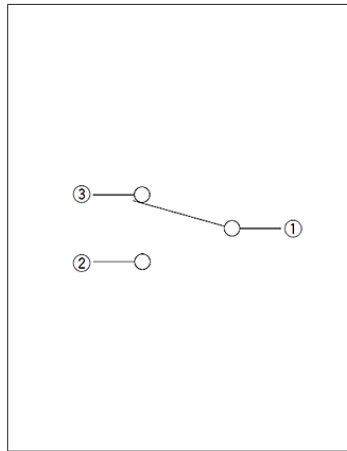

## Drawing No.2

### ■ Dimensions

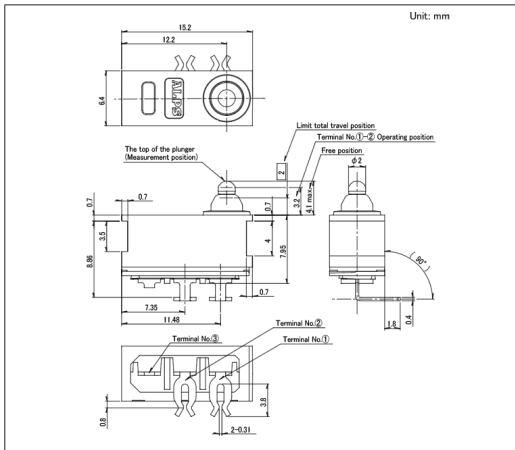

### ■ Circuit Diagram

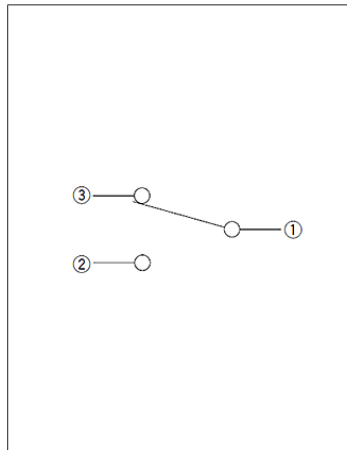

## Drawing No.3

### ■ Dimensions

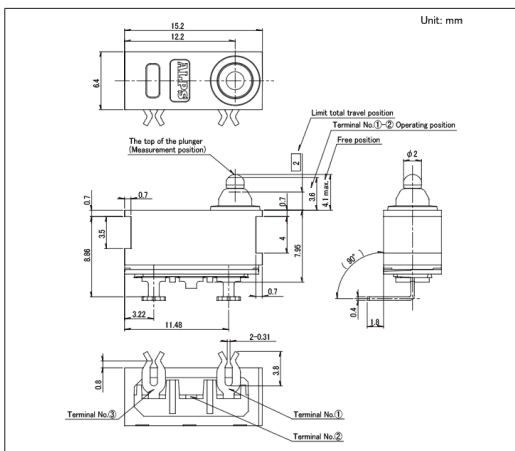

### ■ Circuit Diagram

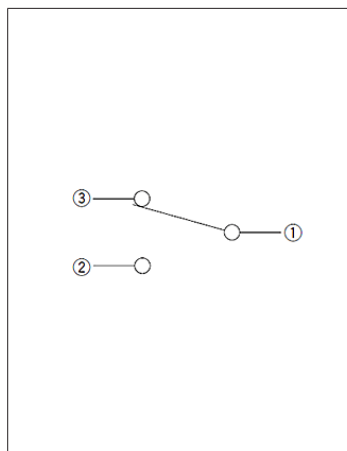

Water-proof Type  
SPVQA Series

Drawing No.4

■ Dimensions

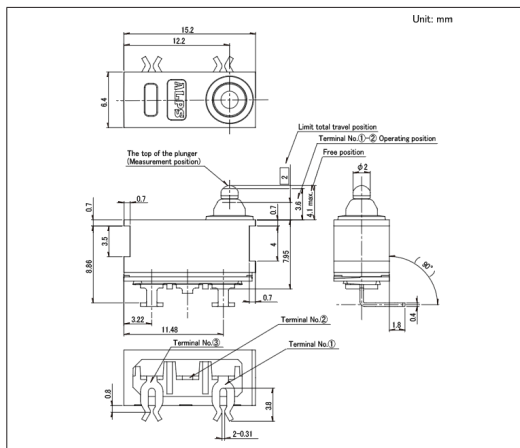

■ Circuit Diagram

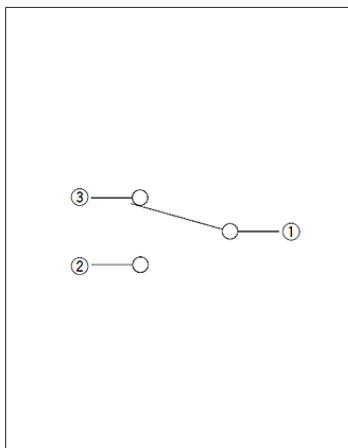

Drawing No.5

■ Dimensions

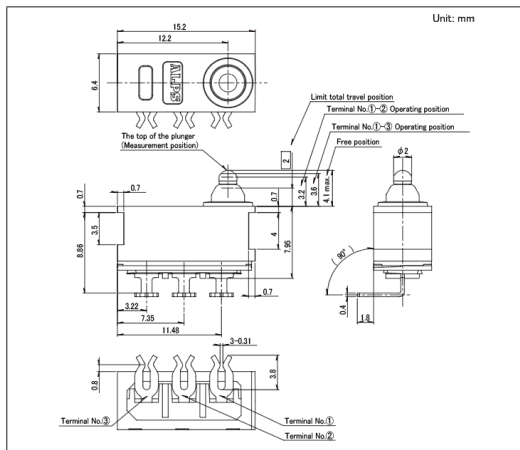

■ Recommended Unit Terminal style

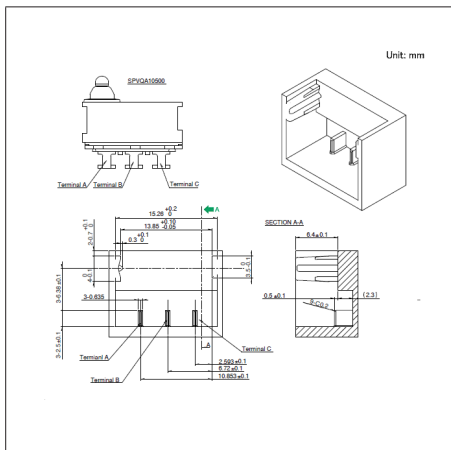

■ Circuit Diagram

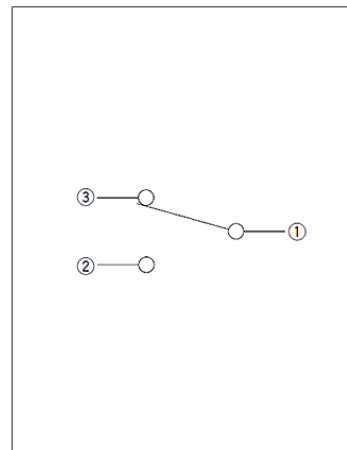

Drawing No.6

■ Dimensions

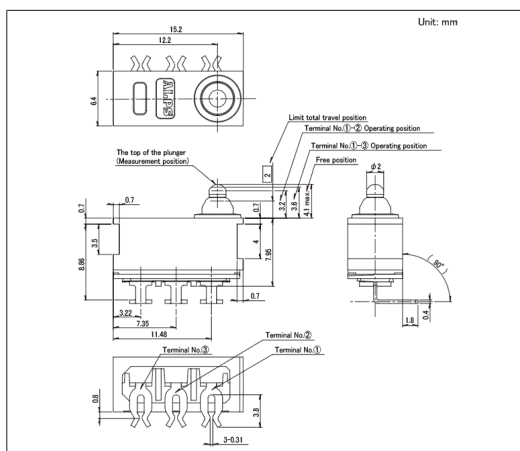

■ Circuit Diagram

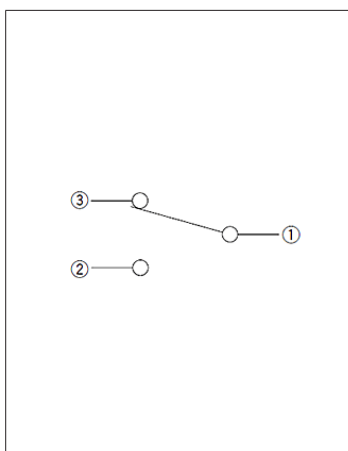

Water-proof Type  
SPVQA Series

Drawing No.7

■ Dimensions

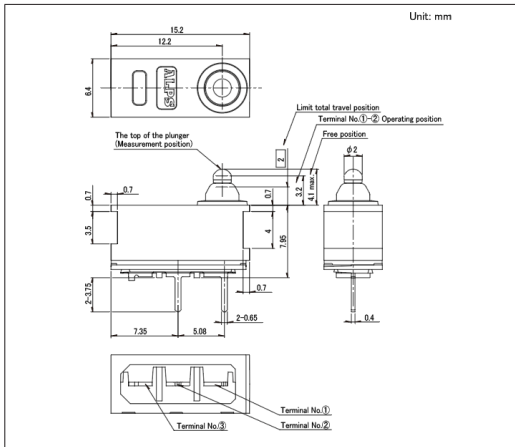

■ Circuit Diagram

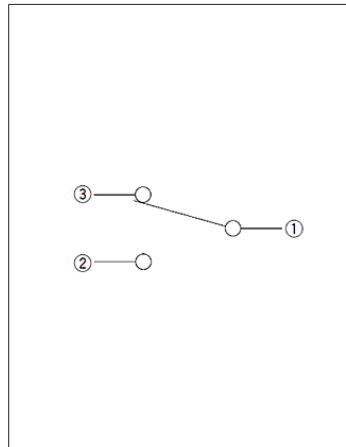

Drawing No.8

■ Dimensions

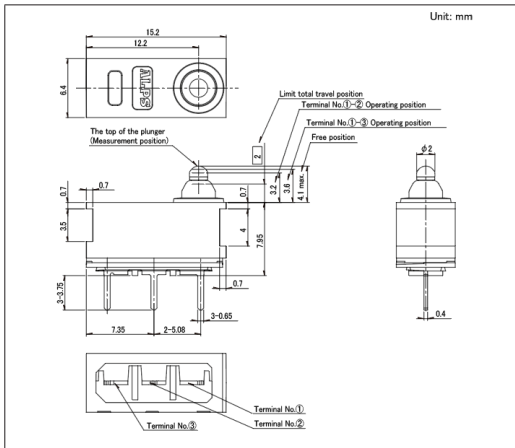

■ Circuit Diagram

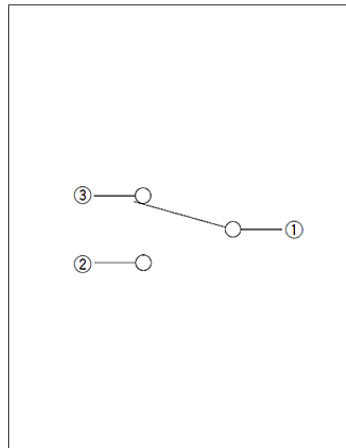

Switches **Detector Switches**

Water-proof Type (Surface Mount)  
**SPVQC Series**

Surface-mount type with a dual-circuit simultaneous switching design ensuring stable contact.



- Automotive
- Water-proof Type
- Dust-proof Type

- Rating(max.)/(min.)(Resistive load): 50mA 18V DC/50μA 5V DC
- Contact resistance(Initial/After operating life): 75mΩ max./200mΩ max.
- Operating life without load: 300,000 cycles
- Operating life with load Rating(max.)(Resistive load): 300,000 cycles 200mΩ max.

Applications: Automotive: Electric Parking Brake

■ Product List

Products No.	Poles	Positions	Operating force	Changeover timing	Operation part shape	Terminal type	Dimensions (W×D×H) (mm)	Water-proof	Dust-proof	Automotive	Drawing No.
<b>SPVQC10201</b>	2	2	1±0.5N	Non shorting	Push	For PC board (Reflow)	7.4×15.4×7.5	●	●	●	1

Note

1. This catalog shows only outline specifications. When using the products, please obtain formal specifications for supply.
2. This unit cannot be used in water (IP6K7 rating, except for terminal).
3. Please place purchase orders for taping products per minimum order unit (1 reel or a case).
4. This products can be used in vehicles.

Although these products are designed to perform over a wide operating temperature range, please ensure that you receive and read the formal delivery specifications before use.

■ Packing Specifications

Taping

Number of packages(pcs.)			Tape width (mm)	Export package measurements (mm)
1 reel	1 case / Japan	1 case / export packing		
300	1,200	2,400	32	403 x 403 x 360

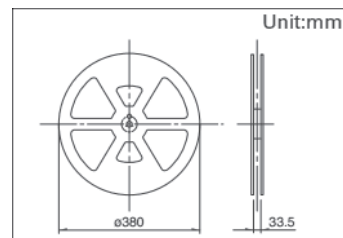

Drawing No.1

■ Dimensions

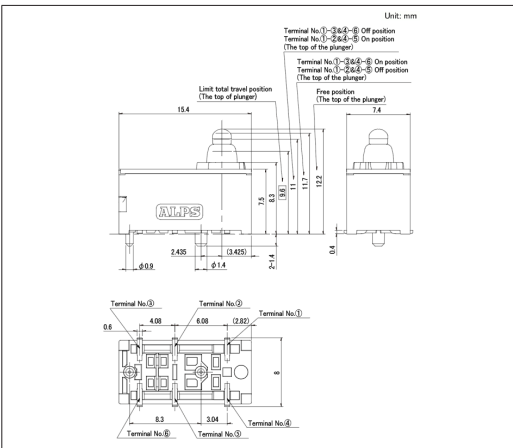

■ Land Dimensions

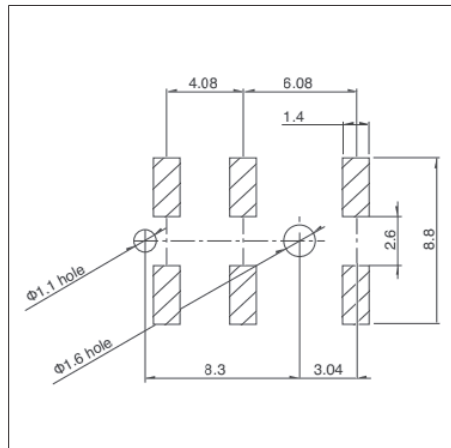

■ Circuit Diagram

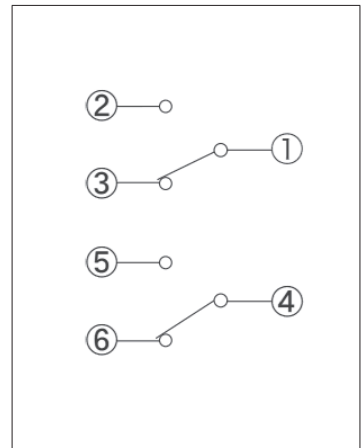

Switches **Detector Switches**

Water-proof Type (Surface Mount)  
**SPVQF Series**

2-circuit synchronous snap action, compact and quiet type



- Automotive
- Water-proof Type
- Dust-proof Type

- Rating(max.)/(min.)(Resistive load): 50mA 18V DC/50μA 5V DC
- Contact resistance(Initial/After operating life): 75mΩ max./2Ω max.
- Operating life without load: 300,000 cycles
- Operating life with load Rating(max.)(Resistive load): 300,000 cycles 2Ω max.

Applications: Automotive: Electric Parking Brake

■ Product List

Products No.	Poles	Positions	Operating force	Changeover timing	Operation part shape	Terminal type	Dimensions (W×D×H) (mm)	Water-proof	Dust-proof	Automotive	Drawing No.
SPVQF10201	2	2	1.8N max.	Non shorting	Push	For PC board (Reflow)	6.3×8.5×7.0	●	●	●	1

Note

1. This catalog shows only outline specifications. When using the products, please obtain formal specifications for supply.
2. This unit cannot be used in water (IP6K7 rating, except for terminal).
3. Please place purchase orders for taping products per minimum order unit (1 reel or a case).
4. This products can be used in vehicles.

Although these products are designed to perform over a wide operating temperature range, please ensure that you receive and read the formal delivery specifications before use.

■ Packing Specifications

Taping

Number of packages (pcs.)			Tape width (mm)	Export package measurements (mm)
1 reel	1 case / Japan	1 case / export packing		
400	800	1,600	24	428 x 413 x 172

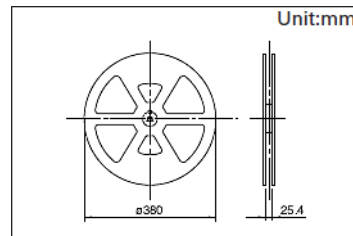

**Drawing No.1**

■ Dimensions

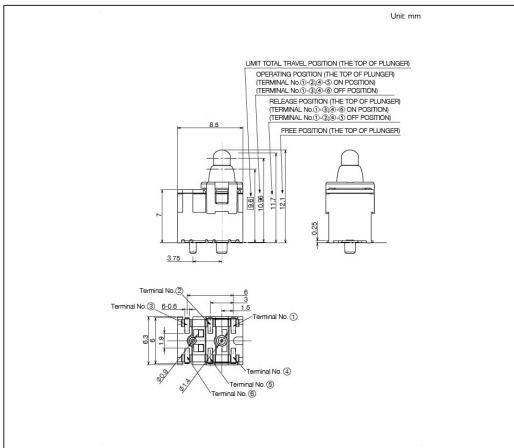

■ Land Dimensions

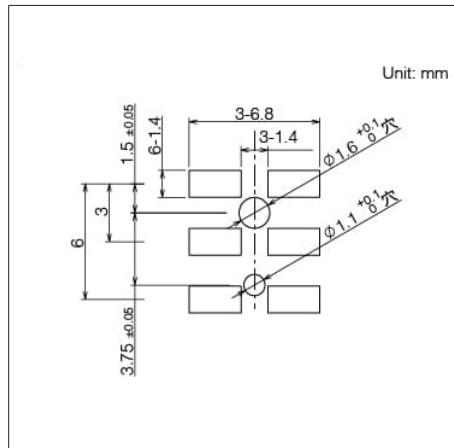

■ Circuit Diagram

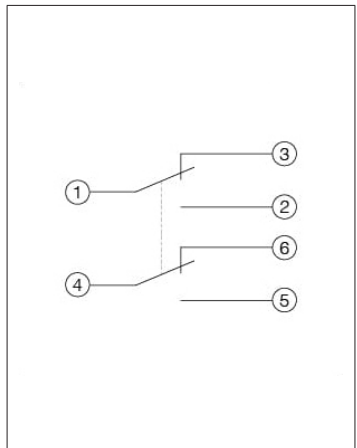

Switches **Detector Switches**

Water-proof Lever Type  
**SSCN Series**

Water-proof lever switch capable of left-right detection with a 40° operating angle per side.

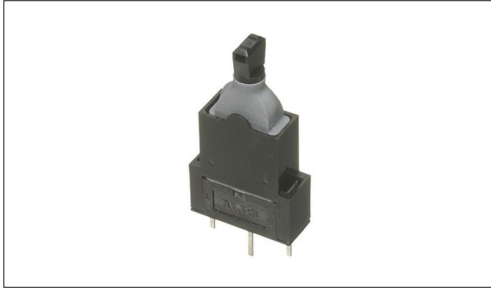

- Automotive
- Water-proof Type
- Dust-proof Type

- Rating(max.)/(min.)(Resistive load):0.1A 12V DC/100μA 5V DC
- Contact resistance(Initial/After operating life):500mΩ max./1Ω max.
- Operating life without load:100,000 cycles
- Operating life with load Rating(max.)(Resistive load):  
100,000 cycles 1Ω max.

Applications:Energy\_Industrial:Robots, drones,Industrial equipment  
Home:Major home appliances  
Automotive:Hood Latch (Side/Rear/Door/Gear)

■ Product List

Products No.	Poles	Positions	Operating force	Changeover timing	Terminal type	Dimensions (W×D×H) (mm)	Water-proof	Dust-proof	Automotive	Drawing No.
SSCN110101	1	2	2N max.	Non shorting	For PC board	5.0×13.0×15.0	●	●	●	1

**Note**

1. This catalog shows only outline specifications. When using the products, please obtain formal specifications for supply.
2. This unit cannot be used in water (IP6K7 rating, except for terminal).
3. Please place purchase orders per minimum order unit (integer).
4. This products can be used in vehicles.

Although these products are designed to perform over a wide operating temperature range, please ensure that you receive and read the formal delivery specifications before use.

■ Packing Specifications

Tray

Number of packages (pcs.)		Export package measurements (mm)
1 case / Japan	1 case / export packing	
600	2,400	540 x 360 x 270

**Drawing No.1**

■ Dimensions

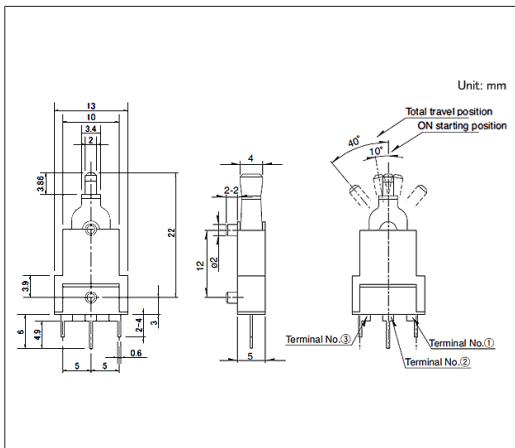

■ Circuit Diagram

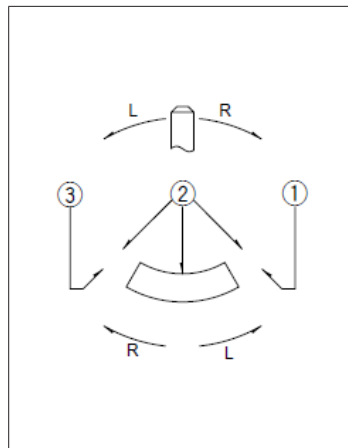

Switches **Detector Switches**

Water-proof Switch Compatible with 10mA to 4.5A  
**SDDH Series**

Compliant with IP6K8 waterproofing standards, enabling submerged operation.



- 🚗 Automotive
- 💧 Water-proof Type
- 🌫️ Dust-proof Type

- Rating(max.)/(min.)(Resistive load):4.5A 12V DC/10mA 12V DC
- Contact resistance(Initial/After operating life):500mΩ max./1Ω max.
- Operating life without load:100,000 cycles
- Operating life with load Rating(max.)(Resistive load):  
 100,000 cycles 1Ω max.

Applications:Automotive:Motorcycles

■ Product List

Products No.	Poles	Positions	Operating force	Terminal type	Circuit	Dimensions (W×D×H) (mm)	Water-proof	Dust-proof	Automotive	Drawing No.
<b>SDDHA10100</b>	1	1	4.6N max.	Snap-in Tab Terminal (#187)	SPST (normally closed)	28.5×9.0×24.3	●	●	●	1

**⚠️ Note**

1. This catalog shows only outline specifications. When using the products, please obtain formal specifications for supply.
2. Please place purchase orders per minimum order unit (integer).
3. This products can be used in vehicles.  
 Although these products are designed to perform over a wide operating temperature range, please ensure that you receive and read the formal delivery specifications before use.

■ Packing Specifications

Tray

Number of packages (pcs.)		Export package measurements (mm)
1 case / Japan	1 case / export packing	
180	360	400 x 270 x 185

**Drawing No. 1**

■ Dimensions

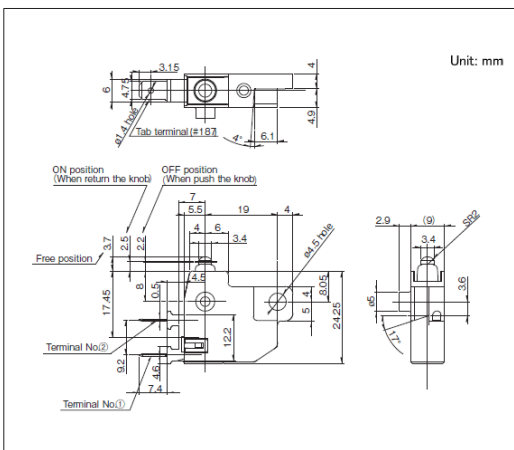

■ Circuit Diagram

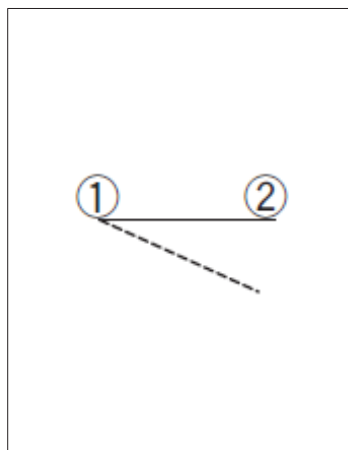

## Detector Switches / Soldering Conditions

### ■ Example of Reflow Soldering Condition

1. Heating method: Double heating method with infrared heater.
2. Temperature measurement: Thermocouple  $\phi 0.1$  to  $0.2$  CA(K) or CC(T) at soldering portion (copper foil surface).  
A heat resisting tape should be used for fixed measurement.
3. Temperature profile

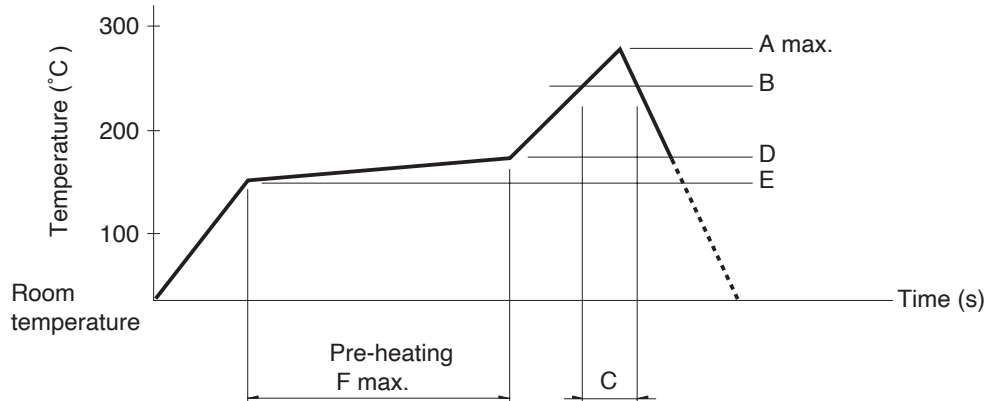

Series (Reflow type)	A (°C) 3s max.	B (°C)	C (s)	D (°C)	E (°C)	F (s)
SPPB	250	230	40	180	150	120
SPVE	260					
SPVL						
SPVM						
SPVN						
SPVR						
SPVS						
SPVT						
SSCM						
SSCQ						
SPVQC	250					
SPVQF						

#### ⚠ Note

1. The condition mentioned above is the temperature on the mounting surface of a PC board. There are cases where the PC board's temperature greatly differs from that of the switch, surface depending on the PC board's material, size, thickness, etc.  
The above-stated conditions shall also apply to switch surface temperatures.
2. Soldering conditions differ depending on reflow soldering machines.  
Prior verification of soldering condition is highly recommended.

### ■ Reference for Hand Soldering

Series	Soldering temperature	Soldering time
SPVS, SPVN, SPVT, SPVM, SPVR, SPVE, SSCQ, SSCM, SPVL, SSCT, SPVQC, SPVQF	350±5°C	3s max.
SPVQ3, SPVQ6, SPVQ7, SPVQ8, SPVQ9, SSCN, SPVQA	300±10°C	3+1/0s
SPPB (Reflow)	300±5°C	5s max.
SSCF, SPPB (For Lead, Dip)	350±10°C	3+1/0s

### ■ Reference for Dip Soldering

(For PC board terminal types)

Series	Items		Dip soldering	
	Preheating temperature	Preheating time	Soldering temperature	Duration of immersion
SSCT, SPVQ3, SPVQ6, SPVQ7, SPVQ8, SPVQ9, SPVQA	100±10°C	60s max.	260±5°C	5±1s
SPPW8, SPPB	100 °C max.	60s max.	255±5°C	5±1s
SSCF	—		260±5°C	5±1s







## Detector Switches / Cautions

1. Applying load to terminals during soldering under certain conditions may cause deformation and electrical property degradation.
2. Avoid use of water-soluble soldering flux, since it may corrode the switches.
3. Check and conform to soldering requirements under actual mass production conditions.
4. No washing.
5. The products are designed and manufactured for direct current resistance. Contact us for use of other resistances such as inductive (L) or capacitive (C).
6. The circuit setting (software setting) shall be ensured for error-free operations, caused by bounce and chattering as specified by each model of the switches.
7. Do not use the switches for a long time near the upper or lower limits of the specified operating temperatures. The use environments shall satisfy the specified range of the environmental tests in the specifications.
8. In case of continuous operation near the upper and lower limits, see requirements of each model to check if possible.
9. The switches designed specifically for automotive uses can be used for vehicles. No other switches shall be used for vehicles.
10. Use the switches sufficiently distant (i.e. at a position closer to the full distance) from the ON Start Position.
11. The switch-returning force cannot be used as a mechanical driving force of a set.
12. Do not apply transverse force to the operating part while piling up PC boards in process and during transportation.
13. Protect small and thin switches from external forces in the set mounting process.
14. Use of a through-hole PC board, or a PC board of different thickness from the recommendation will have a different heat stress. Verify the soldering requirements thoroughly before use.
15. Warped PC boards may change their properties. Carefully design and lay-out the patterns.
16. Use of thinner PC boards will require extra care, since the switches may be floated.
17. Use of the switches in a dusty environment may lead the dusts entering through the openings and cause imperfect contact or malfunction. Take this into account for set design.
18. Corrosive gas if generated by peripheral parts of a set, malfunction such as imperfect contact may occur. Thorough investigation shall be required beforehand.
19. Storage  
Store the products as delivered at normal temperature and humidity, out of direct sunlight and away from corrosive gases. Use them as soon as possible and no later than six months after delivery.  
Once the seal is broken, use them as soon as possible.

## Switches

## Slide Switches

## List of Varieties

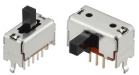
Series		SSAJ	SSSS8	SSAG	SSSS7	SSSS2	SSSS9	SSSF		
Photo										
Actuator directions	Horizontal	●	●	●	●	●	●	●		
	Vertical	—	●	—	—	●	●	●		
Dimensions (mm)		2.5×5.5×0.7	6.7×2.6×1.4 6.7×4.1×1.4 9.7×2.6×1.4 9.7×4.1×1.4	3.0×9.05×1.15	8.8×3.0×2.0 12.5×3.0×2.0	8.5×3.5×3.5 9.0×3.5×3.5 13.0×3.5×3.5 15.0×3.5×3.5	11.5×4.7×5.0 11.5×4.7×5.5 11.5×7.2×5.0 11.5×7.2×5.5 14.0×4.7×5.5 14.0×7.2×5.0 14.0×7.2×5.5	14.5×7.0×8.5 16.5×7.0×8.5		
Poles		1	1 2	1	1	1	2	1 2 4		
Positions		2	2 3	3	2 3	2 3 4	2 3	2 3		
Operating force		1.5±1N	Refer to the dimensions	1N (Recoil side) 1N (Recoil side), 1.5N (Lock side)	Refer to the dimensions.		3±1.5N a, c → b 2±1N b → a, c 3±1.5N	Refer to the dimensions.		
Operating temperature range		-10°C to +60°C	-40°C to +85°C	-10°C to +60°C	-40°C to +85°C					
Rating (max.)/(min.) (Resistive load)		10mA 5V DC/ 50μA 3V DC	0.3A 5V DC/ 50μA 3V DC	10mA 5V DC/ 50μA 3V DC	0.3A 4V DC/ 50μA 3V DC	0.3A 6V DC/ 50μA 3V DC	0.1A 12V DC/ 1mA 5V DC	0.1A 30V DC/ 50μA 3V DC		
Electrical performance	Contact resistance (Initial performance/ After lifetime)	300mΩ max./ 500mΩ max.	70mΩ max./ 130mΩ max.	200mΩ max./ 500mΩ max.	70mΩ max./ 130mΩ max.		30mΩ max./ 80mΩ max.	25mΩ max./ 65mΩ max.		
	Insulation resistance	100MΩ min. 100V DC				100MΩ min. 500V DC				
	Voltage proof	100V AC for 1 minute				500V AC for 1 minute				
Mechanical performance	Terminal strength		3N for 1 minute					5N for 1 minute		
	Actuator strength	Operating direction	10N			20N		30N		
		Pulling direction	10N						30N	
Durability	Operating life without load	10,000 cycles 500mΩ max.	10,000 cycles 100mΩ max.	100,000 cycles 500mΩ max. 100,000 cycles 500mΩ max. (Recoil side) 30,000 cycles 500mΩ max. (Lock side)	10,000 cycles 100mΩ max.	100 cycles 100mΩ max. 10,000 cycles 100mΩ max.	10,000 cycles 60mΩ max.	10,000 cycles 45mΩ max.		
	Operating life with load (at max. rated load)	10,000 cycles 500mΩ max.	10,000 cycles 130mΩ max.	100,000 cycles 500mΩ max. 100,000 cycles 500mΩ max. (Recoil side) 30,000 cycles 500mΩ max. (Lock side)	10,000 cycles 130mΩ max.	100 cycles 130mΩ max. 10,000 cycles 130mΩ max.	10,000 cycles 80mΩ max.	10,000 cycles 65mΩ max.		
Environmental performance	Cold	-40°C 96h	-40°C 500h	-40°C 96h	-40°C 500h					
	Dry heat	85°C 96h	85°C 500h	85°C 96h	85°C 500h					
	Damp heat	40°C, 90 to 95%RH 96h	60°C, 90 to 95%RH 500h	40°C, 90 to 95%RH 96h	60°C, 90 to 95%RH 500h					
Automotive		—	—	—	—	—	—	—		



● Indicates applicability to all products in the series, while ○ indicates applicability to some products in the series.

# Slide Switches

Series		SSSU	
Photo			
Actuator directions	Horizontal	●	
	Vertical	●	
Dimensions (mm)		18.5×7.0×8.5 21.5×7.0×8.5 24.5×7.0×8.5	
Poles		1 2 4	
Positions		2 3	
Operating force		Refer to the dimensions.	
Operating temperature range		-40°C to +85°C	
Rating (max.)/(min.) (Resistive load)		0.1A 30V DC/ 50μA 3V DC	
Electrical performance	Contact resistance (Initial performance/ After lifetime)	25mΩ max./ 65mΩ max.	
	Insulation resistance	100MΩ min. 500V DC	
	Voltage proof	500V AC for 1 minute	
Mechanical performance	Terminal strength	5N for 1 minute	
	Actuator strength	Operating direction	30N
		Pulling direction	30N
Durability	Operating life without load	10,000 cycles 45mΩ max.	
	Operating life with load (at max. rated load)	10,000 cycles 65mΩ max.	
Environmental performance	Cold	-40°C 500h	
	Dry heat	85°C 500h	
	Damp heat	60°C, 90 to 95%RH 500h	
Automotive		—	

### Note

● Indicates applicability to all products in the series, while ○ indicates applicability to some products in the series.

Switches Slide Switches

0.7mm (H), 1.4mm-travel (Surface Mount)

# SSAJ Series

Compact type with a body height of 0.7mm.



- Rating (max.)/(min.) (Resistive load): 10mA 5V DC/50μA 3V DC
- Contact resistance (Initial performance/After lifetime): 300mΩ max./500mΩ max.
- Operating life without load: 10,000 cycles 500mΩ max.
- Operating life with load (at max. rated load): 10,000 cycles 500mΩ max.

Applications: Mobile: Smartphones, tablets, Headsets, wearables, Notebooks, peripherals  
 Energy\_Industrial: Robots, drones, Industrial equipment, Converters  
 Game: Home handheld consoles, Virtual/augmented reality  
 Healthcare: Healthcare equipment, Nursing care equipment, Analysis, test equipment  
 Audio\_TV: Audio, Cameras

■ Product List

Products No.	Actuator directions	Travel (mm)	Poles	Positions	Operating force	Changeover timing	Soldering	Location lug	Dimensions (W×D×H) (mm)	Automotive	Drawing No.
SSAJ110100	Horizontal	1.4	1	2	1.5±1N	Not specified	Reflow	With	2.5×5.5×0.7	—	1
SSAJ120100	Horizontal	1.4	1	2	1.5±1N	Not specified	Reflow	Without	2.5×5.5×0.7	—	2

**Note**

1. This catalog shows only outline specifications. When using the products, please obtain formal specifications for supply.
2. Please place purchase orders for taping products per minimum order unit (1 reel or a case).

■ Packing Specifications

Taping

Number of packages (pcs.)			Tape width (mm)	Export package measurements (mm)
1 reel	1 case / Japan	1 case / export packing		
5,000	10,000	20,000	16	417 x 409 x 1.39

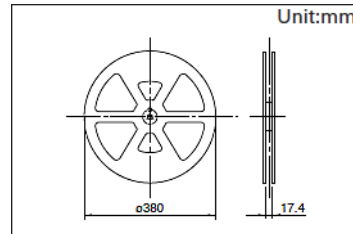

## Drawing No.1

■ Dimensions

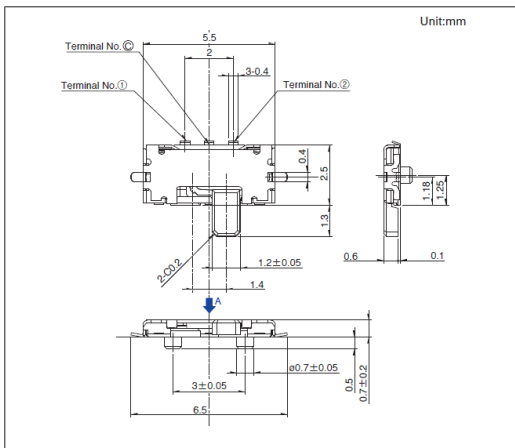

■ Land Dimensions

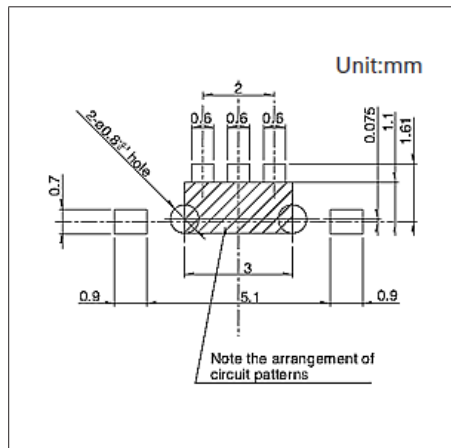

■ Circuit Diagram

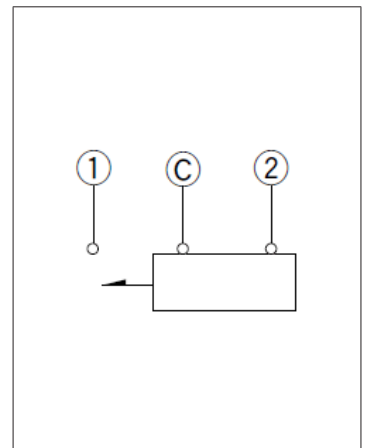

0.7mm (H), 1.4mm-travel (Surface Mount)  
**SSAJ Series**

**Drawing No.2**

■ Dimensions

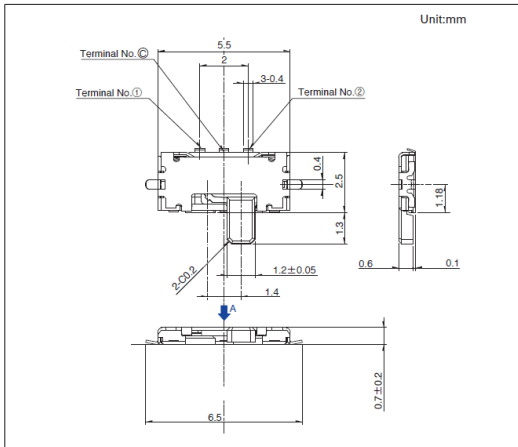

■ Land Dimensions

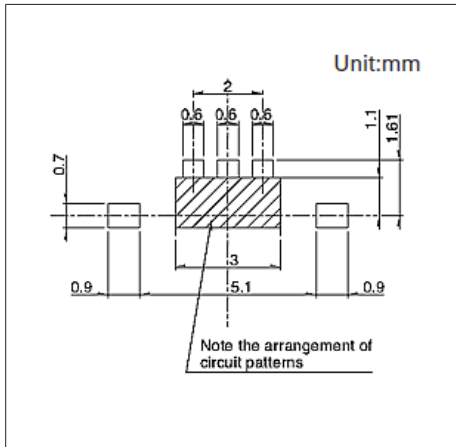

■ Circuit Diagram

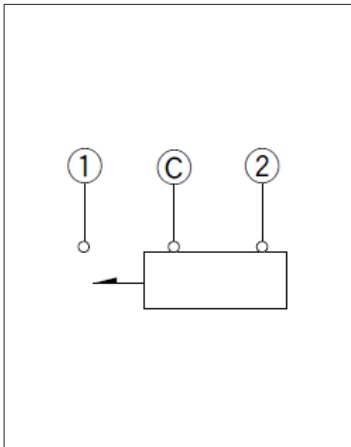

## Switches

## Slide Switches

1.4 (H) mm, 1.5/2.0mm-travel (Surface Mount)

## SSSS8 Series

Thin-profile type with a body height of 1.4mm.

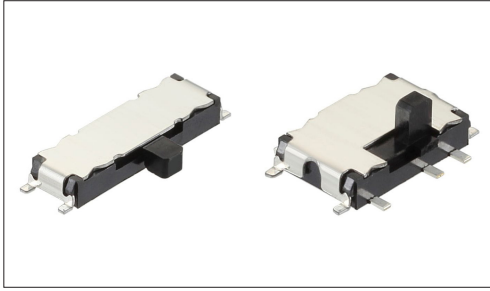

- Rating (max.)/(min.) (Resistive load): 0.3A 5V DC/50 $\mu$ A 3V DC
- Contact resistance (Initial performance/After lifetime):  
70m $\Omega$  max./130m $\Omega$  max.
- Operating life without load: 10,000 cycles 100m $\Omega$  max.
- Operating life with load (at max. rated load): 10,000 cycles 130m $\Omega$  max.

Applications: Mobile: Smartphones, tablets, Headsets, wearables,  
Notebooks, peripherals  
Energy\_Industrial: Robots, drones, Industrial equipment,  
Converters  
Game: Home handheld consoles, Virtual/augmented reality  
Healthcare: Healthcare equipment, Nursing care equipment,  
Analysis, test equipment  
Audio\_TV: Audio, Cameras

## ■ Product List

Products No.	Actuator directions	Travel (mm)	Poles	Positions	Operating force	Changeover timing	Ground terminal	Soldering	Dimensions (W×D×H) (mm)	Automotive	Drawing No.
SSSS820101	Vertical	1.5	2	2	Refer to the dimensions	Not specified	Without	Reflow	6.7×4.1×1.4	—	1
SSSS820301	Vertical	1.5	2	3	Refer to the dimensions	Not specified	Without	Reflow	9.7×4.1×1.4	—	2
SSSS820201	Vertical	1.5	2	2	Refer to the dimensions	Not specified	With	Reflow	6.7×4.1×1.4	—	3
SSSS820501	Vertical	1.5	2	3	Refer to the dimensions	Not specified	With	Reflow	9.7×4.1×1.4	—	4
SSSS810701	Horizontal	1.5	1	2	Refer to the dimensions	Not specified	Without	Reflow	6.7×2.6×1.4	—	5
SSSS811501	Horizontal	1.5	1	3	Refer to the dimensions	Not specified	Without	Reflow	9.7×2.6×1.4	—	6
SSSS811101	Horizontal	1.5	1	2	Refer to the dimensions	Not specified	With	Reflow	6.7×2.6×1.4	—	7
SSSS812201	Horizontal	1.5	1	3	Refer to the dimensions	Not specified	With	Reflow	9.7×2.6×1.4	—	8
SSSS810201	Horizontal	2.0	1	2	Refer to the dimensions	Not specified	With	Reflow	9.7×2.6×1.4	—	9

## ⚠ Note

1. This catalog shows only outline specifications. When using the products, please obtain formal specifications for supply.
2. Please place purchase orders for taping products per minimum order unit (1 reel or a case).

## ■ Packing Specifications

## Taping

Products No.	Number of packages(pcs.)			Tape width (mm)	Export package measurements (mm)
	1 reel	1 case / Japan	1 case / export packing		
SSSS820101 SSSS820301 SSSS820201 SSSS820501	1,800	3,600	7,200	24	406 x 406 x 190
SSSS810701 SSSS811501 SSSS811101 SSSS812201 SSSS810201	4,500	9,000	18,000	16	417 x 409 x 139

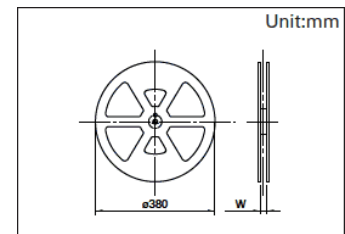

1.4 (H) mm, 1.5/2.0mm-travel (Surface Mount)  
**SSSS8 Series**

**Drawing No.1**

■ Dimensions

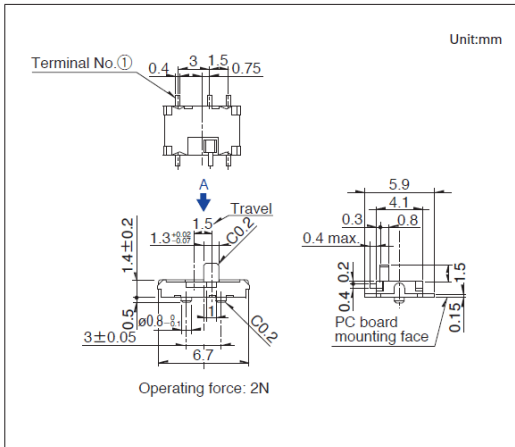

■ Land Dimensions

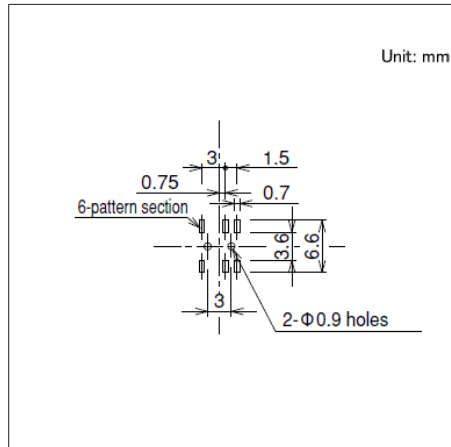

■ Circuit Diagram

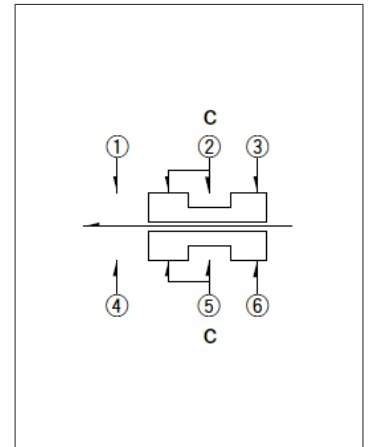

Viewed from direction A in the dimensions.

**Drawing No.2**

■ Dimensions

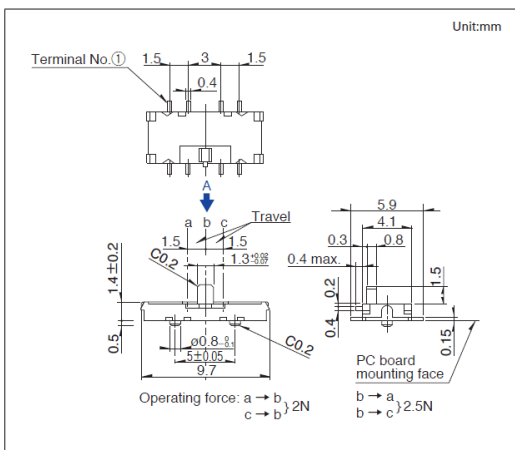

■ Land Dimensions

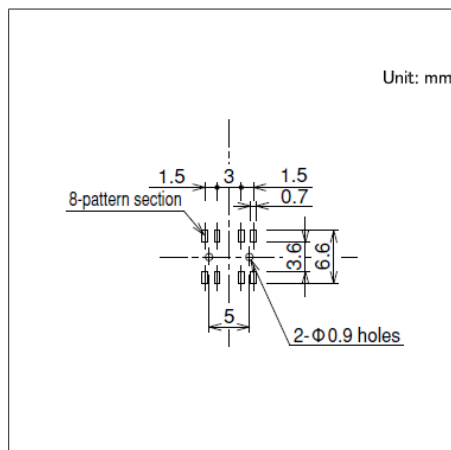

■ Circuit Diagram

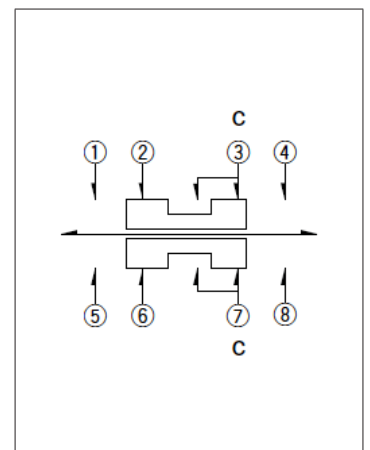

Viewed from direction A in the dimensions.

**Drawing No.3**

■ Dimensions

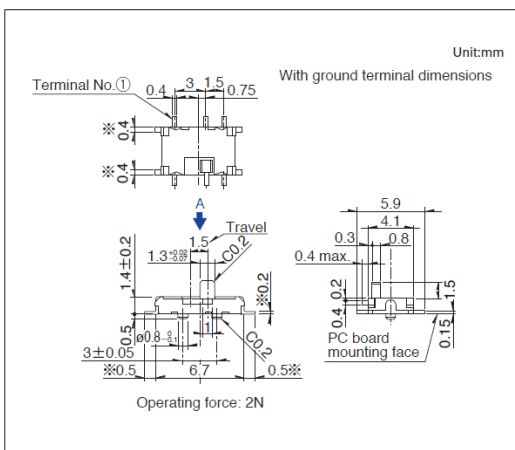

■ Land Dimensions

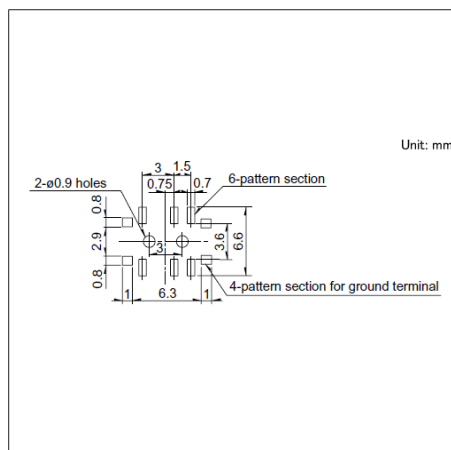

■ Circuit Diagram

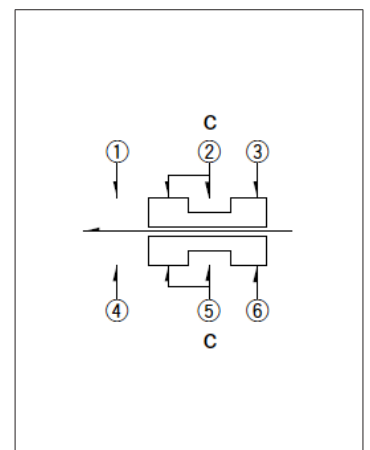

Viewed from direction A in the dimensions.

Switches Slide Switches

1.4 (H) mm, 1.5/2.0mm-travel (Surface Mount)  
SSSS8 Series

Drawing No.4

■ Dimensions

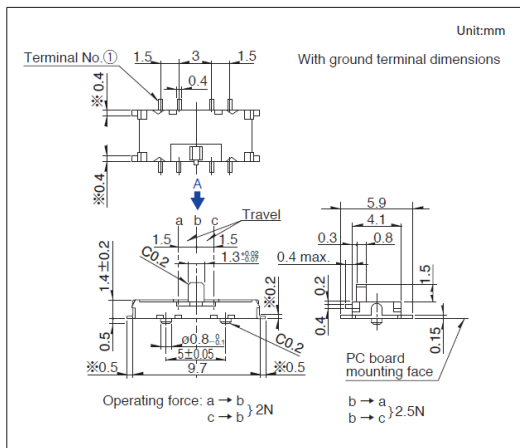

■ Land Dimensions

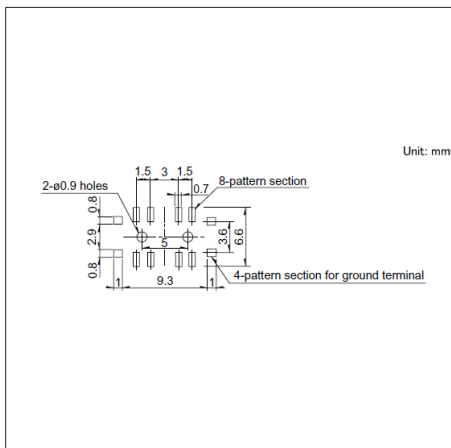

■ Circuit Diagram

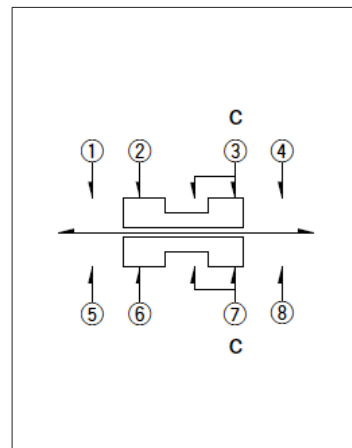

Viewed from direction A in the dimensions.

Drawing No.5

■ Dimensions

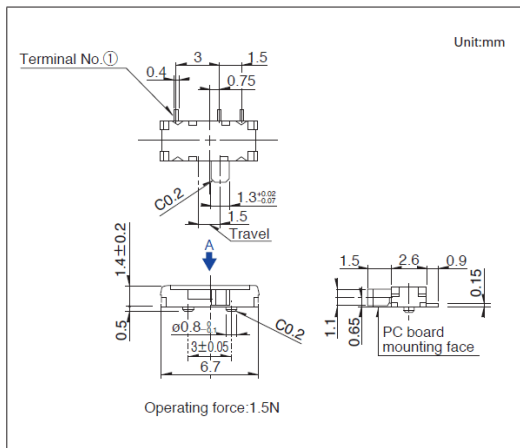

■ Land Dimensions

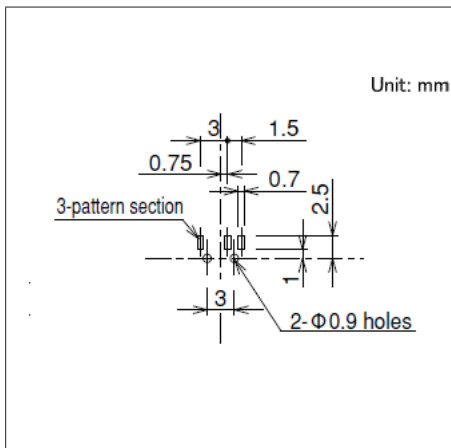

■ Circuit Diagram

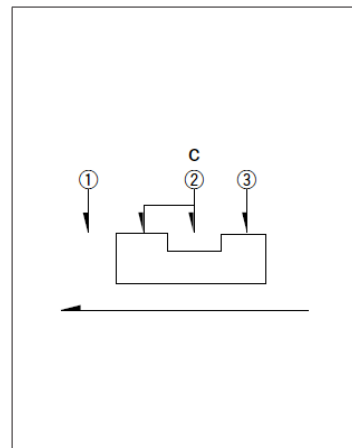

Viewed from direction A in the dimensions.

Drawing No.6

■ Dimensions

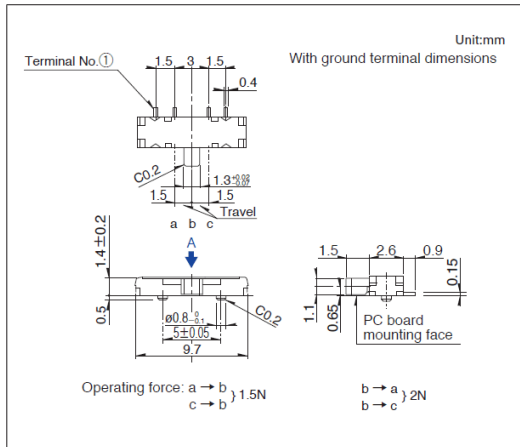

■ Land Dimensions

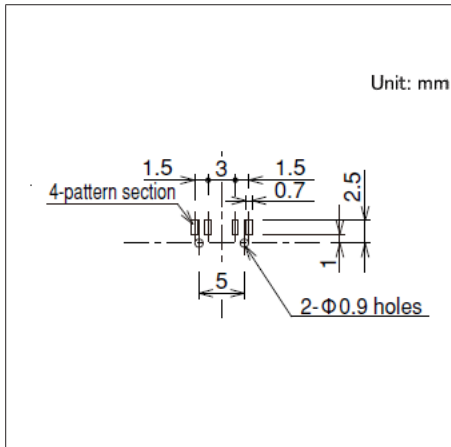

■ Circuit Diagram

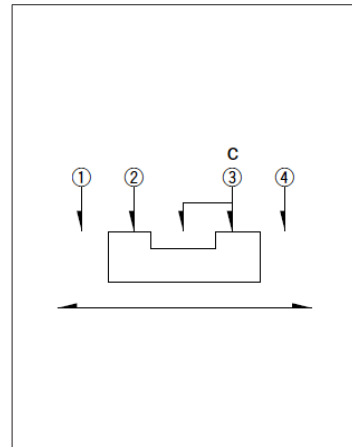

Viewed from direction A in the dimensions.

Switches Slide Switches

1.4 (H) mm, 1.5/2.0mm-travel (Surface Mount)  
SSSS8 Series

Drawing No.7

■ Dimensions

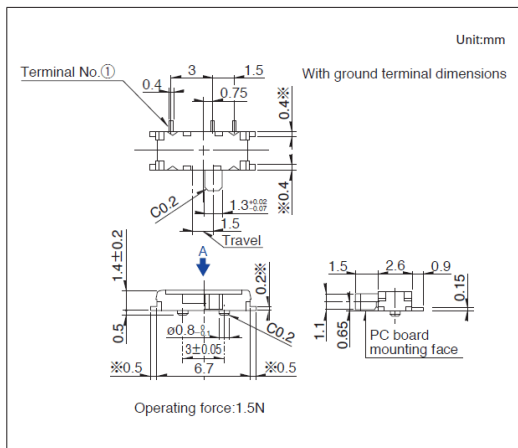

■ Land Dimensions

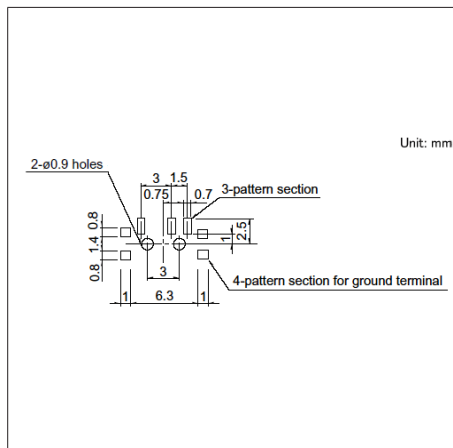

■ Circuit Diagram

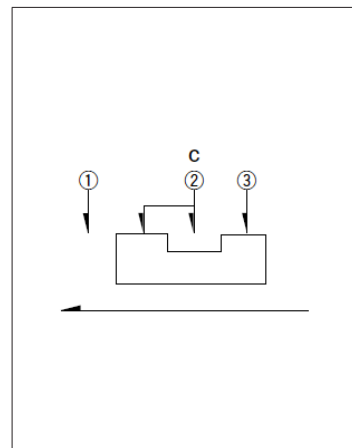

Viewed from direction A in the dimensions.

Drawing No.8

■ Dimensions

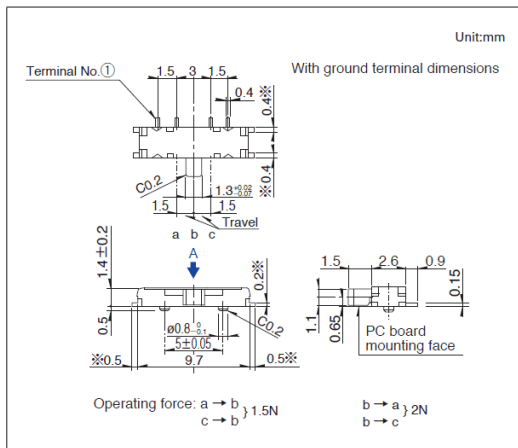

■ Land Dimensions

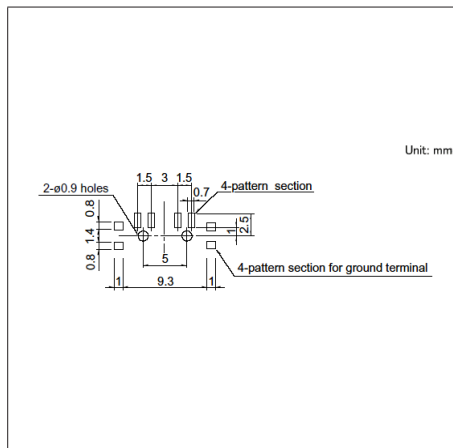

■ Circuit Diagram

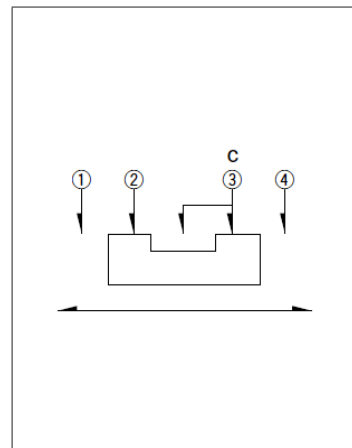

Viewed from direction A in the dimensions.

Drawing No.9

■ Dimensions

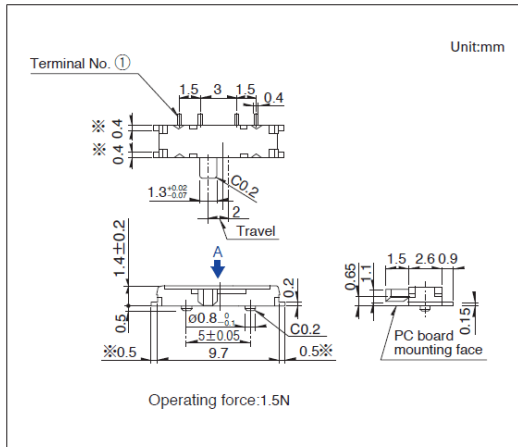

■ Land Dimensions

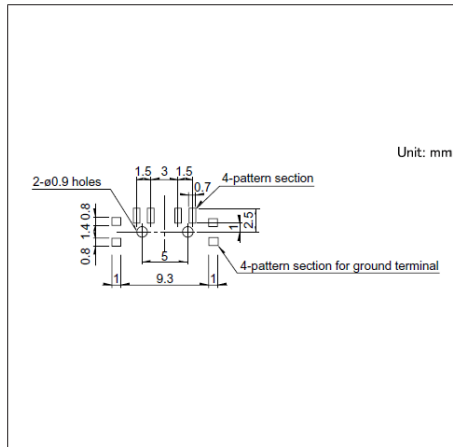

■ Circuit Diagram

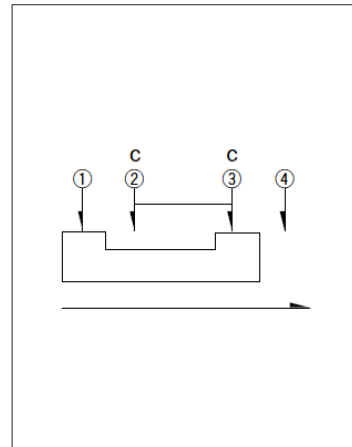

Viewed from direction A in the dimensions.

0.9 (H) mm, Recoil for Single-side and Both-sides

**SSAG Series**

Long-life type designed to meet the evolution toward miniaturization and thin profiles.

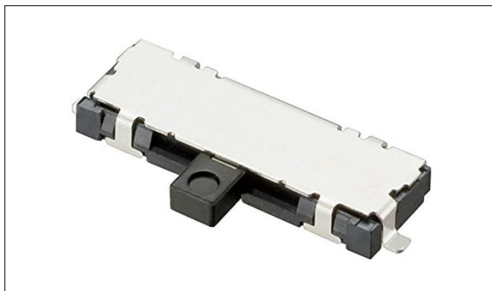

- Rating (max.)/(min.) (Resistive load): 10mA 5V DC/50μA 3V DC
- Contact resistance (Initial performance/After lifetime):  
200mΩ max./500mΩ max.
- Operating life without load: 100,000 cycles 500mΩ max. (Recoil side)  
30,000 cycles 500mΩ max. (Lock side)
- Operating life with load (at max. rated load):  
100,000 cycles 500mΩ max. (Recoil side)  
30,000 cycles 500mΩ max. (Lock side)

Applications: Mobile: Smartphones, tablets, Headsets, wearables,  
Notebooks, peripherals  
Energy\_Industrial: Robots, drones, Industrial equipment,  
Converters  
Game: Home handheld consoles, Virtual/augmented reality  
Healthcare: Healthcare equipment, Nursing care equipment,  
Analysis, test equipment  
Audio\_TV: Audio, Cameras

## ■ Product List

Products No.	Actuator directions	Travel (mm)	Poles	Positions	Operating force	Changeover timing	Soldering	Operation	Shape of frame leg	Location lug	Dimensions (W×D×H) (mm)	Automotive	Drawing No.
SSAG130100	Horizontal	1.5	1	3	1N (Recoil side), 1.5N (Lock side)	Not specified	Reflow	Left-side recoil	For PC board insert	Without	3.0×9.05×1.15	—	1
SSAG130200	Horizontal	1.5	1	3	1N (Recoil side), 1.5N (Lock side)	Not specified	Reflow	Left-side recoil	For PC board insert	With	3.0×9.05×1.15	—	2
SSAG130300	Horizontal	1.5	1	3	1N (Recoil side), 1.5N (Lock side)	Not specified	Reflow	Left-side recoil	Flat	Without	3.0×9.05×1.15	—	3
SSAG130400	Horizontal	1.5	1	3	1N (Recoil side), 1.5N (Lock side)	Not specified	Reflow	Left-side recoil	Flat	With	3.0×9.05×1.15	—	4
SSAG230100	Horizontal	1.5	1	3	1N (Recoil side), 1.5N (Lock side)	Not specified	Reflow	Right-side recoil	For PC board insert	Without	3.0×9.05×1.15	—	5
SSAG230200	Horizontal	1.5	1	3	1N (Recoil side), 1.5N (Lock side)	Not specified	Reflow	Right-side recoil	For PC board insert	With	3.0×9.05×1.15	—	6
SSAG230300	Horizontal	1.5	1	3	1N (Recoil side), 1.5N (Lock side)	Not specified	Reflow	Right-side recoil	Flat	Without	3.0×9.05×1.15	—	7
SSAG230400	Horizontal	1.5	1	3	1N (Recoil side), 1.5N (Lock side)	Not specified	Reflow	Right-side recoil	Flat	With	3.0×9.05×1.15	—	8
SSAG330100	Horizontal	1.5	1	3	1N (Recoil side)	Not specified	Reflow	Double-side recoil	For PC board insert	Without	3.0×9.05×1.15	—	9
SSAG330200	Horizontal	1.5	1	3	1N (Recoil side)	Not specified	Reflow	Double-side recoil	For PC board insert	With	3.0×9.05×1.15	—	10
SSAG330300	Horizontal	1.5	1	3	1N (Recoil side)	Not specified	Reflow	Double-side recoil	Flat	Without	3.0×9.05×1.15	—	11
SSAG330400	Horizontal	1.5	1	3	1N (Recoil side)	Not specified	Reflow	Double-side recoil	Flat	With	3.0×9.05×1.15	—	12

## ⚠ Note

1. This catalog shows only outline specifications. When using the products, please obtain formal specifications for supply.
2. Please place purchase orders for taping products per minimum order unit (1 reel or a case).

Switches

Slide Switches

0.9 (H) mm, Recoil for Single-side and Both-sides  
**SSAG Series**

■ Packing Specifications

Taping

Number of packages (pcs.)			Tape width (mm)	Export package measurements (mm)
1 reel	1 case / Japan	1 case / export packing		
4,000	8,000	16,000	24	428 x 413 x 172

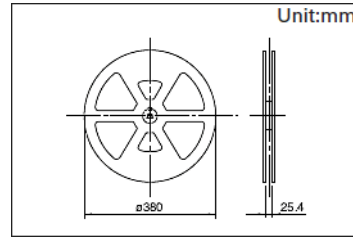

**Drawing No.1**

■ Dimensions

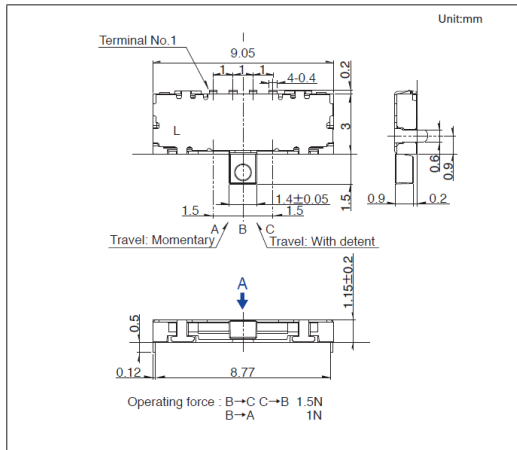

■ Land Dimensions

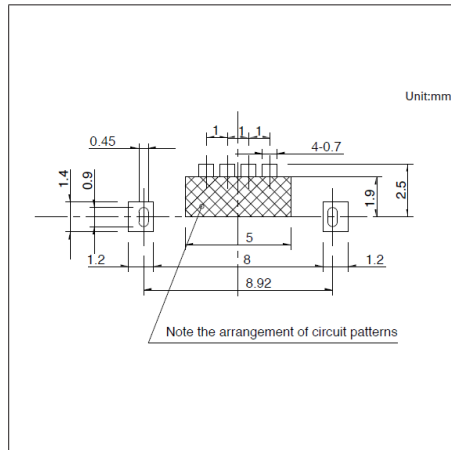

■ Circuit Diagram

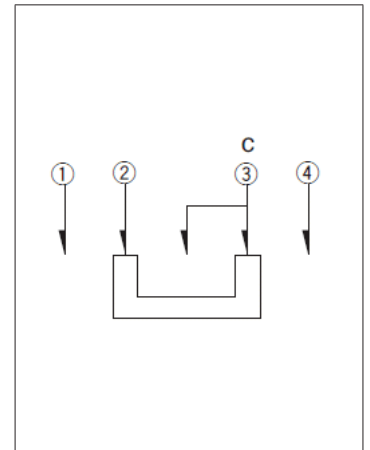

Viewed from direction A in the dimensions.

**Drawing No.2**

■ Dimensions

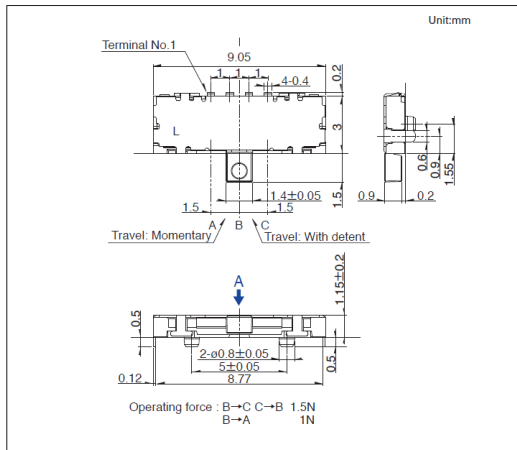

■ Land Dimensions

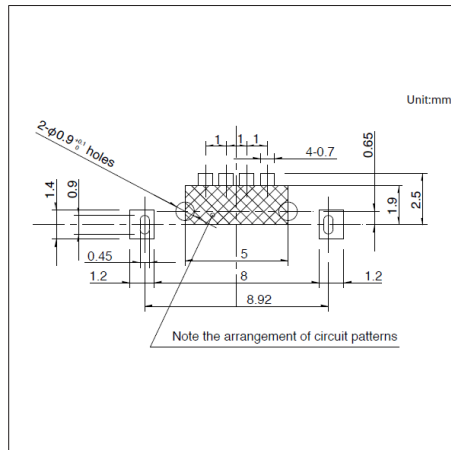

■ Circuit Diagram

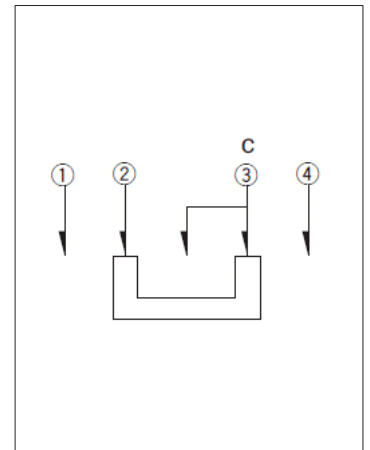

Viewed from direction A in the dimensions.

0.9 (H) mm, Recoil for Single-side and Both-sides  
**SSAG Series**

**Drawing No.3**

■ Dimensions

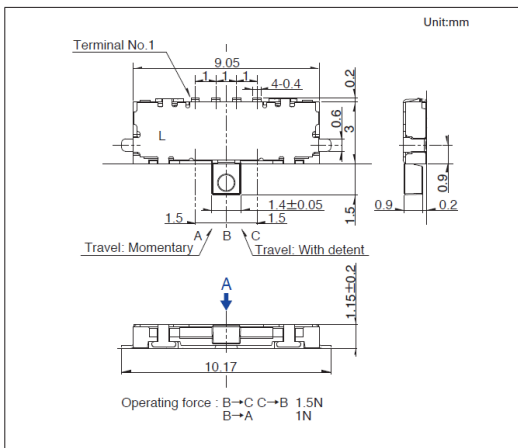

■ Land Dimensions

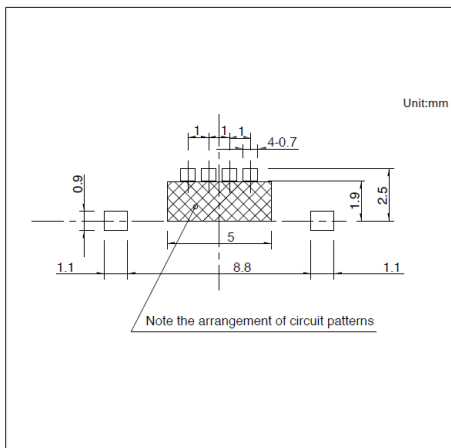

■ Circuit Diagram

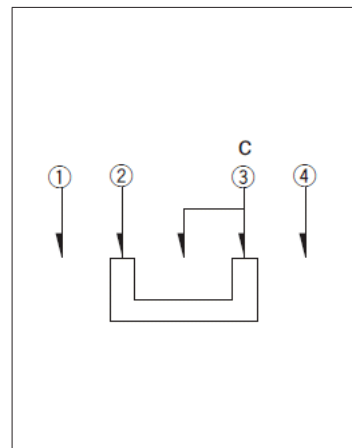

Viewed from direction A in the dimensions.

**Drawing No.4**

■ Dimensions

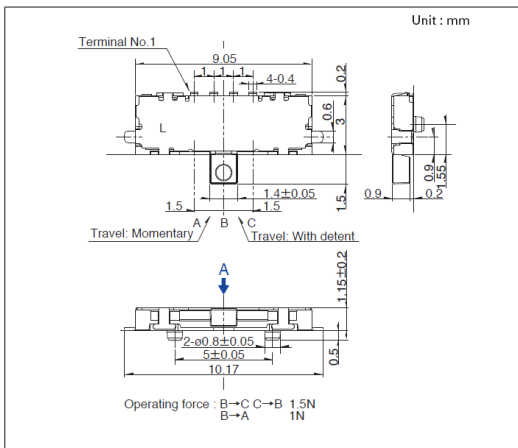

■ Land Dimensions

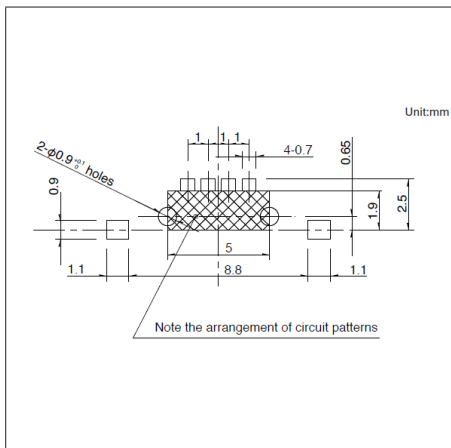

■ Circuit Diagram

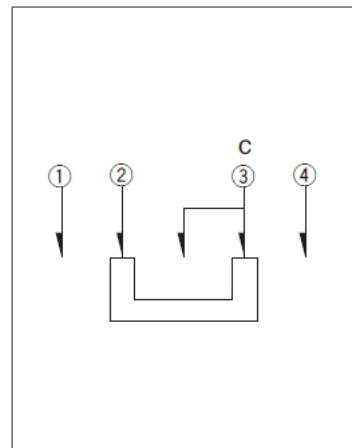

Viewed from direction A in the dimensions.

**Drawing No.5**

■ Dimensions

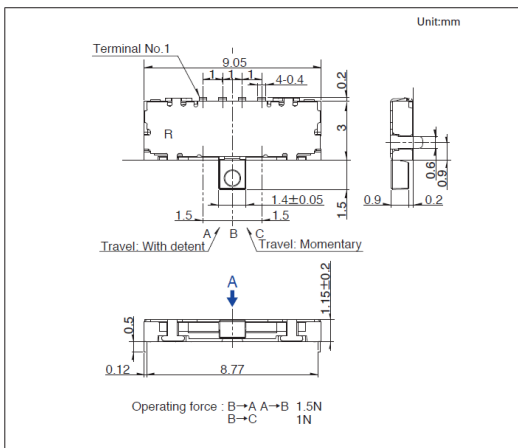

■ Land Dimensions

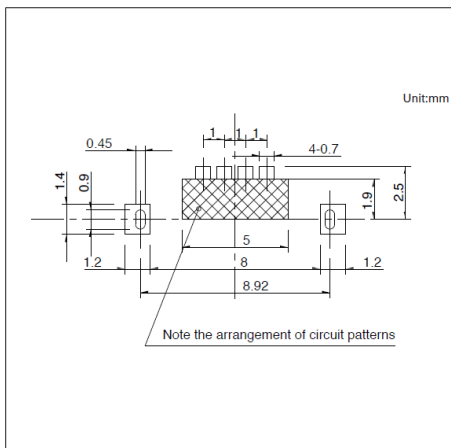

■ Circuit Diagram

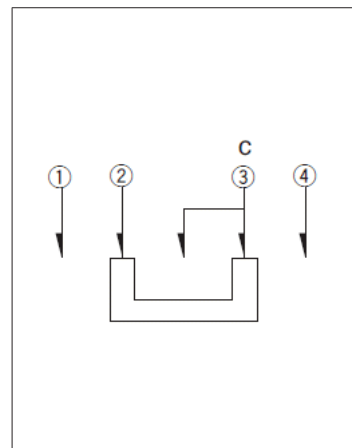

Viewed from direction A in the dimensions.

Switches Slide Switches

0.9 (H) mm, Recoil for Single-side and Both-sides  
**SSAG Series**

**Drawing No.6**

■ Dimensions

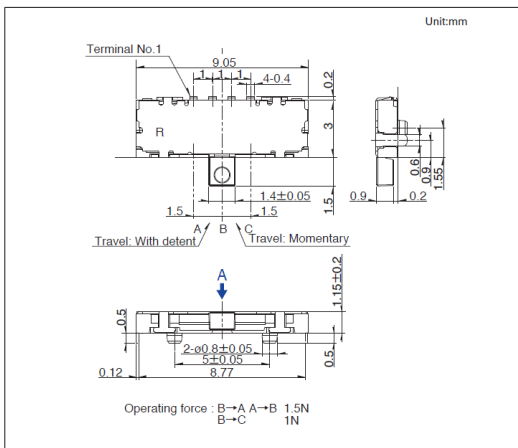

■ Land Dimensions

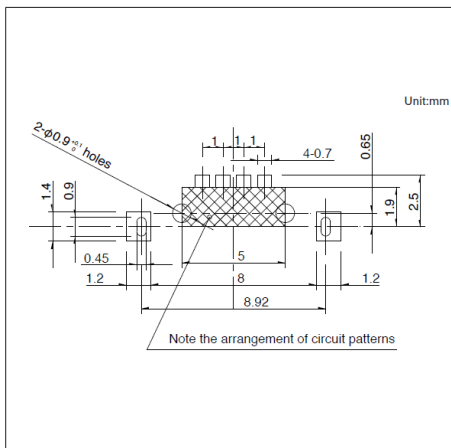

■ Circuit Diagram

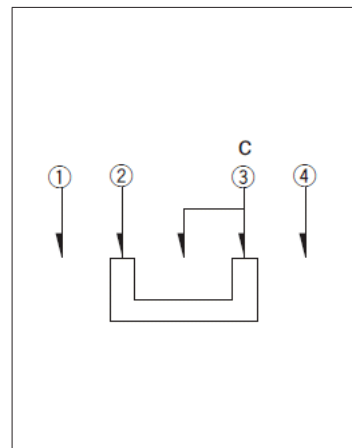

Viewed from direction A in the dimensions.

**Drawing No.7**

■ Dimensions

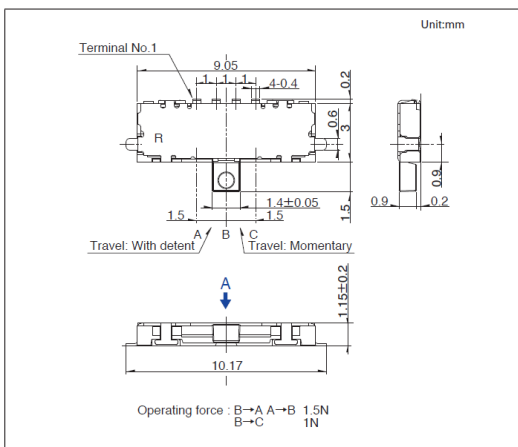

■ Land Dimensions

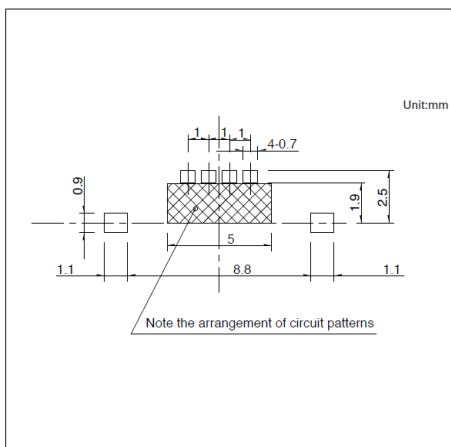

■ Circuit Diagram

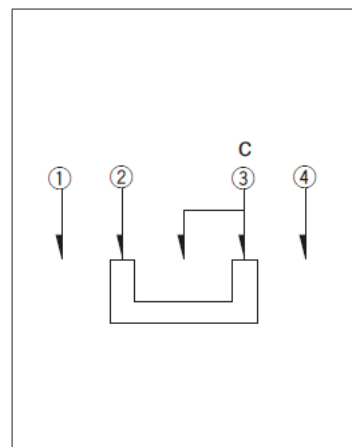

Viewed from direction A in the dimensions.

**Drawing No.8**

■ Dimensions

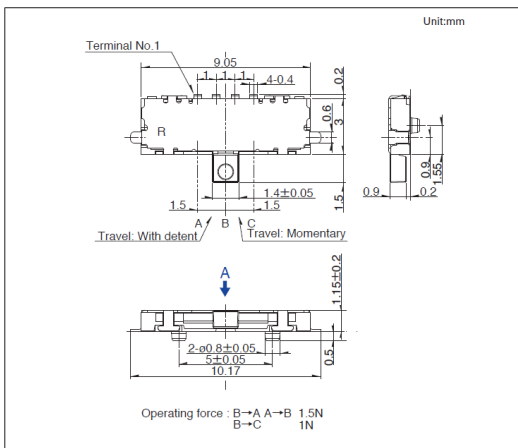

■ Land Dimensions

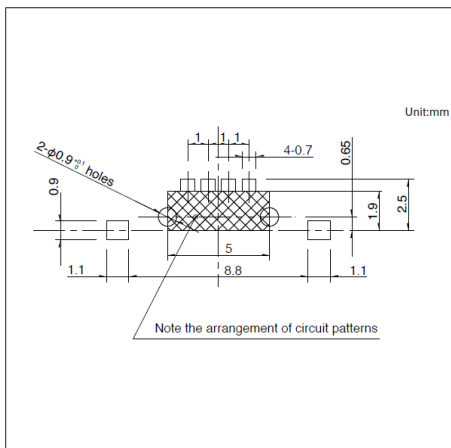

■ Circuit Diagram

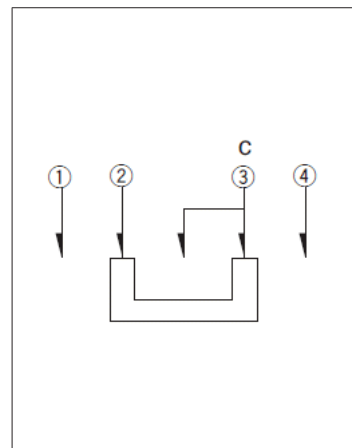

Viewed from direction A in the dimensions.

Switches Slide Switches

0.9 (H) mm, Recoil for Single-side and Both-sides  
**SSAG Series**

**Drawing No.9**

■ Dimensions

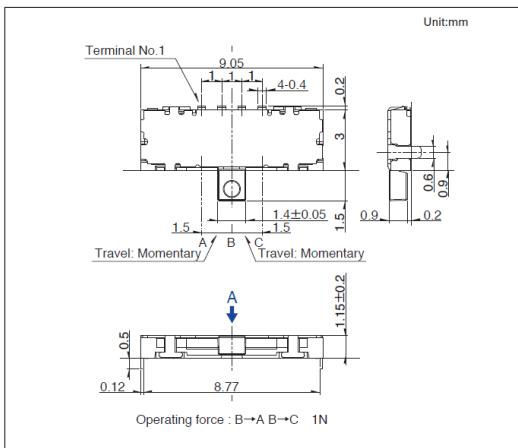

■ Land Dimensions

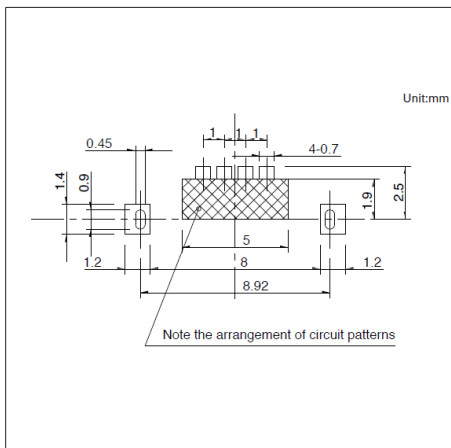

■ Circuit Diagram

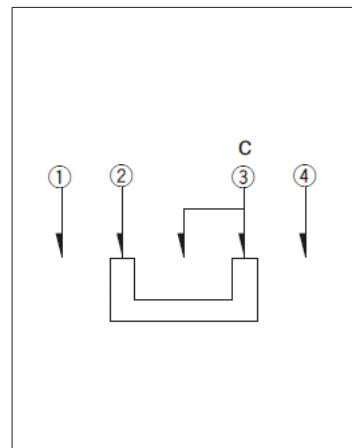

Viewed from direction A in the dimensions.

**Drawing No.10**

■ Dimensions

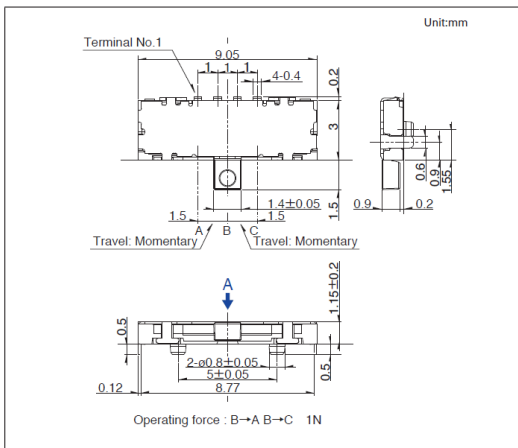

■ Land Dimensions

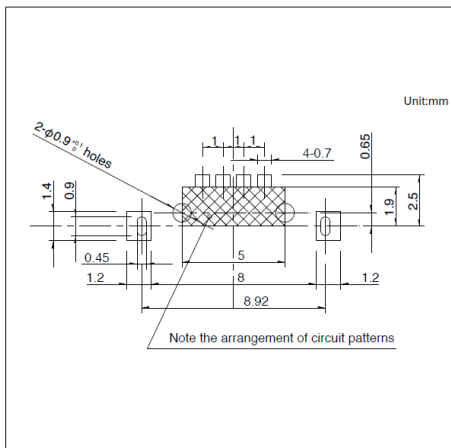

■ Circuit Diagram

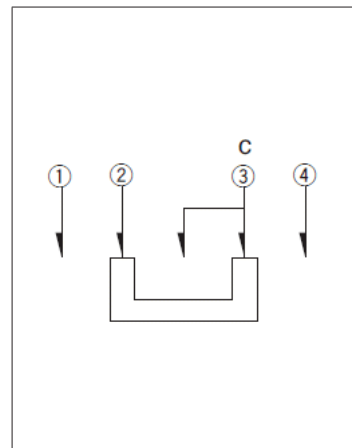

Viewed from direction A in the dimensions.

**Drawing No.11**

■ Dimensions

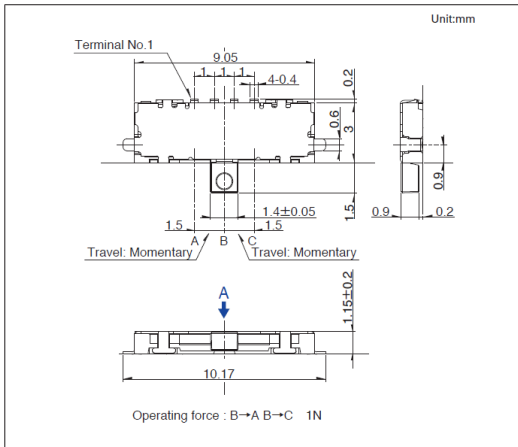

■ Land Dimensions

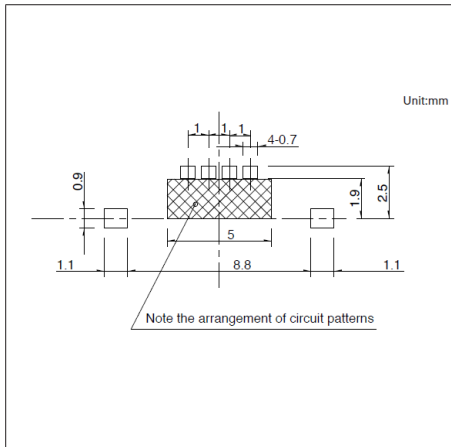

■ Circuit Diagram

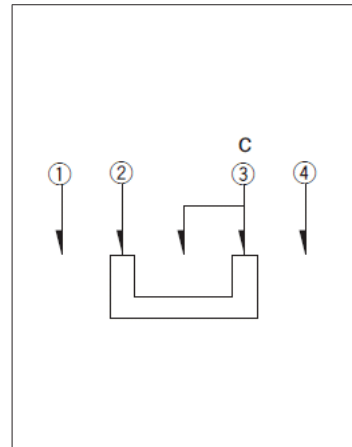

Viewed from direction A in the dimensions.

**Drawing No.12**

■ Dimensions

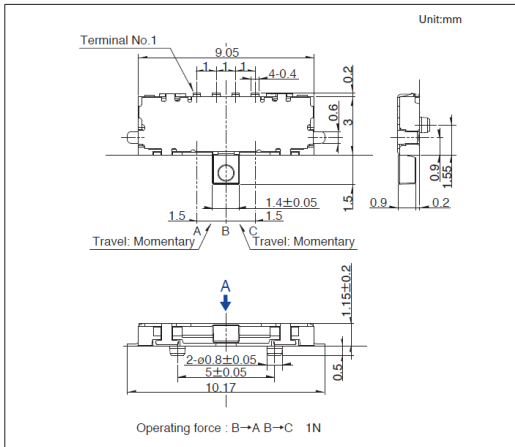

■ Land Dimensions

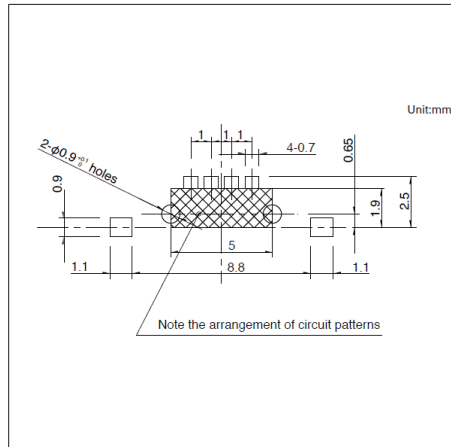

■ Circuit Diagram

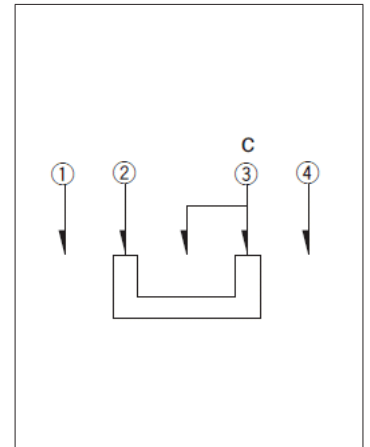

Viewed from direction A in the dimensions.

## Switches

## Slide Switches

2.0 (H) mm, 2.0mm-travel  
**SSSS7 Series**

Compact general-purpose type with selectable soldering methods.



- Rating (max.)/(min.) (Resistive load): 0.3A 4V DC/50 $\mu$ A 3V DC
- Contact resistance (Initial performance/After lifetime):  
70m $\Omega$  max./130m $\Omega$  max.
- Operating life without load: 10,000 cycles 100m $\Omega$  max.
- Operating life with load (at max. rated load): 10,000 cycles 130m $\Omega$  max.

Applications: Mobile: Notebooks, peripherals  
Audio\_TV: Cameras

## ■ Product List

Products No.	Actuator directions	Travel (mm)	Poles	Positions	Operating force	Changeover timing	Soldering	Operation	Dimensions (W×D×H) (mm)	Automotive	Drawing No.
<b>SSSS710100</b>	Horizontal	2.0	1	2	Refer to the dimensions.	Not specified	Manual	Standard	8.8×3.0×2.0	—	1
<b>SSSS710607</b>	Horizontal	2.0	1	2	Refer to the dimensions.	Not specified	Reflow	Standard	8.8×3.0×2.0	—	2
<b>SSSS711100</b>	Horizontal	2.0	1	3	Refer to the dimensions.	Non shorting	Manual	Standard	12.5×3.0×2.0	—	3
<b>SSSS711403</b>	Horizontal	2.0	1	3	Refer to the dimensions.	Non shorting	Reflow	Standard	12.5×3.0×2.0	—	4

## ⚠ Note

1. This catalog shows only outline specifications. When using the products, please obtain formal specifications for supply.
2. Please place purchase orders per minimum order unit (integer).
3. Please place purchase orders for taping products per minimum order unit (1 reel or a case).

## ■ Packing Specifications

## Bulk

Products No.	Number of packages(pcs.)		Export package measurements (mm)
	1 case / Japan	1 case / export packing	
<b>SSSS710100</b>	10,000	50,000	400 x 270 x 290
<b>SSSS711100</b>	8,000	40,000	400 x 270 x 290

## Taping

Products No.	Number of packages(pcs.)			Tape width (mm)	Export package measurements (mm)
	1 reel	1 case / Japan	1 case / export packing		
<b>SSSS710607</b>	2,000	4,000	8,000	16	417 x 409 x 139
<b>SSSS711403</b>	2,000	4,000	8,000	24	406 x 406 x 190

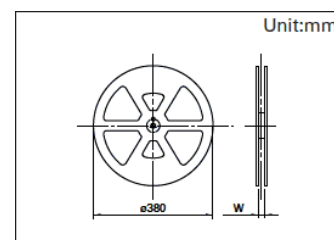

Switches Slide Switches

2.0 (H) mm, 2.0mm-travel  
SSSS7 Series

Drawing No.1

■ Dimensions

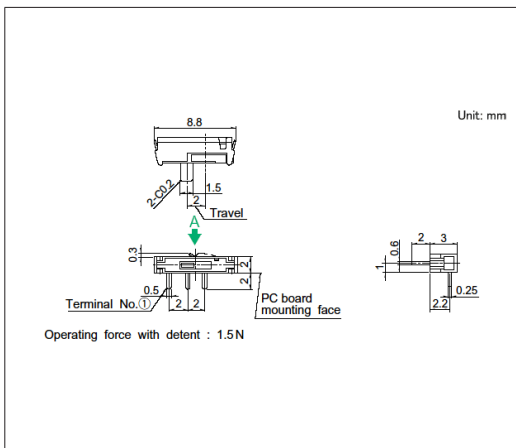

■ Mounting Hole Dimensions

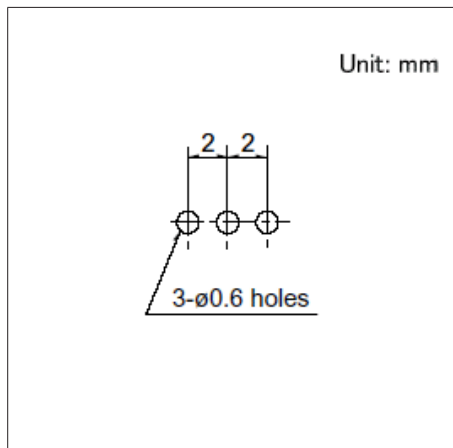

■ Circuit Diagram

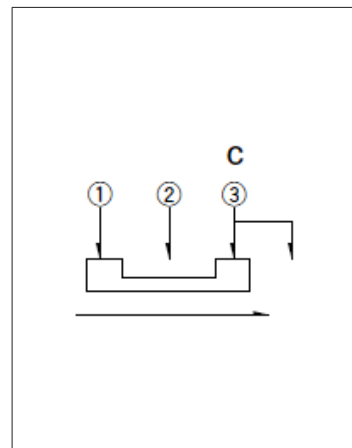

Viewed from direction A in the dimensions.

Drawing No.2

■ Dimensions

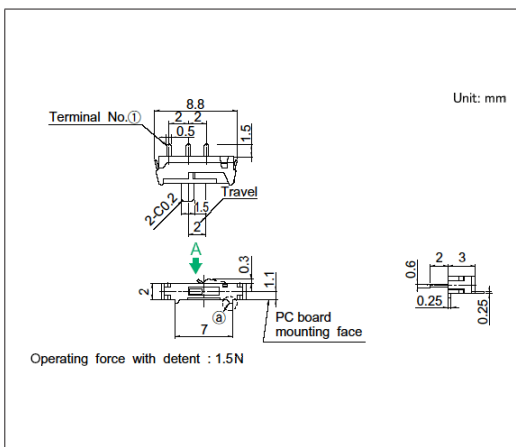

■ Land Dimensions

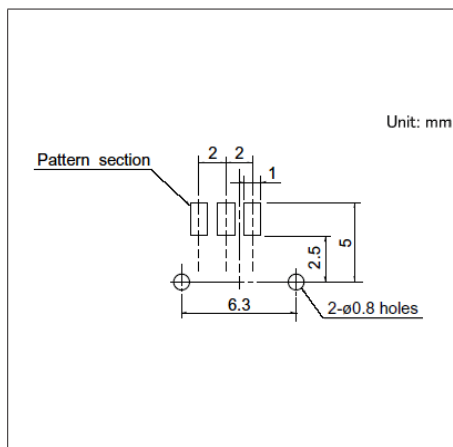

■ Circuit Diagram

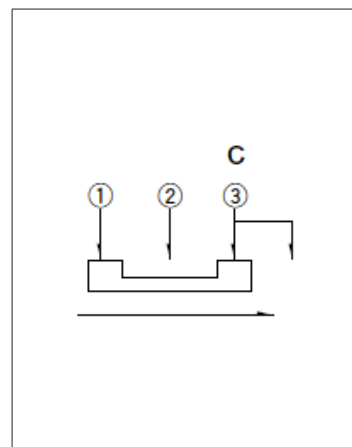

Refer to the website for detail of ②

Viewed from direction A in the dimensions.

Drawing No.3

■ Dimensions

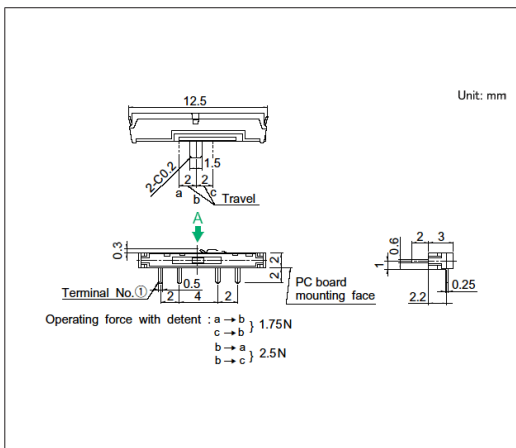

■ Mounting Hole Dimensions

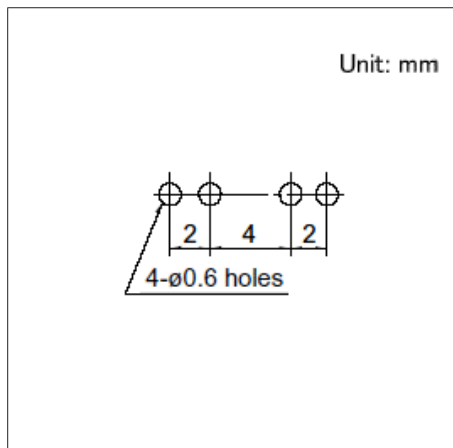

■ Circuit Diagram

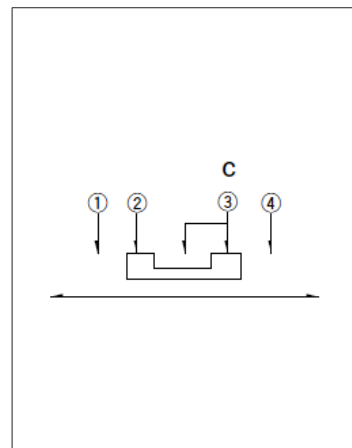

Viewed from direction A in the dimensions.

**Drawing No.4**

■ Dimensions

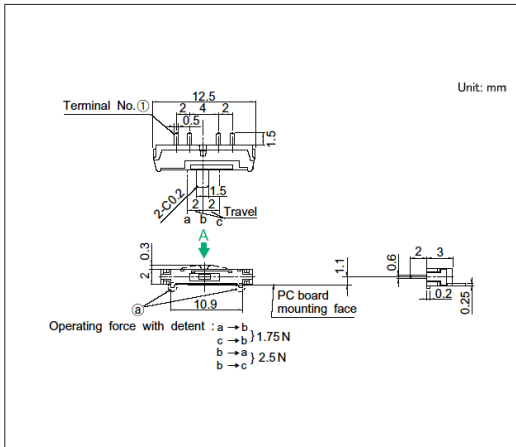

Refer to the website for detail of ©

■ Land Dimensions

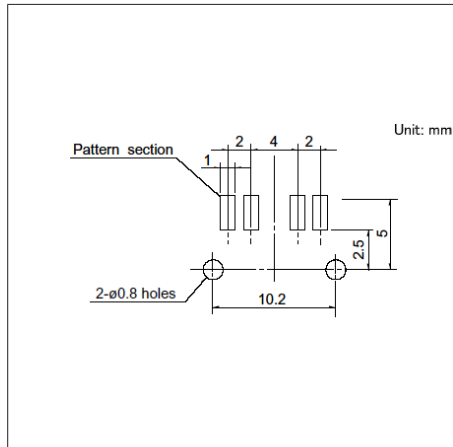

Viewed from direction A in the dimensions.

■ Circuit Diagram

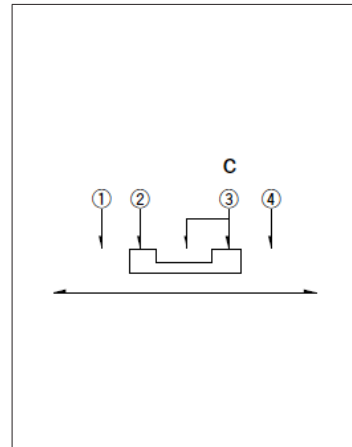

## Switches

## Slide Switches

3.5 (H) mm, 2.0mm-travel  
**SSSS2 Series**

Supports miniaturization and high-density integration for various mobile devices.

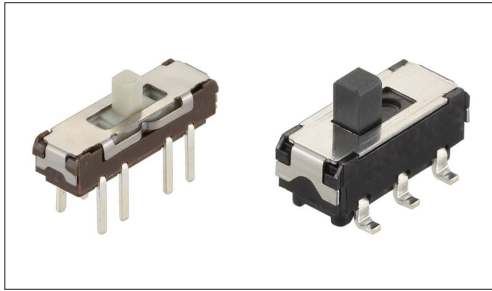

- Rating (max.)/(min.) (Resistive load): 0.3A 6V DC/50 $\mu$ A 3V DC
  - Contact resistance (Initial performance/After lifetime):  
70m $\Omega$  max./130m $\Omega$  max.
  - Operating life without load: 10,000 cycles 100m $\Omega$  max. ※
  - Operating life with load (at max. rated load): 10,000 cycles 130m $\Omega$  max. ※
- ⚠ **Note** ※SSSS213202 only 100 cycles

Applications: Healthcare: Healthcare equipment  
Home: Major home appliances  
Audio\_TV: Audio

## ■ Product List

Products No.	Actuator directions	Travel (mm)	Poles	Positions	Operating force	Changeover timing	Soldering	Dimensions (W×D×H) (mm)	Automotive	Drawing No.
SSSS213000	Vertical	2.0	1	2	Refer to the dimensions.	Non shorting	Manual, Dip	9.0×3.5×3.5	—	1
SSSS211900	Vertical	2.0	1	3	Refer to the dimensions.	Non shorting	Manual, Dip	13.0×3.5×3.5	—	2
SSSS222700	Vertical	2.0	2	2	Refer to the dimensions.	Non shorting	Manual, Dip	9.0×3.5×3.5	—	3
SSSS223600	Vertical	2.0	2	3	Refer to the dimensions.	Non shorting	Manual, Dip	13.0×3.5×3.5	—	4
SSSS213202	Vertical	2.0	1	2	Refer to the dimensions.	Non shorting	Reflow	8.5×3.5×3.5	—	5
SSSS212901	Vertical	2.0	1	3	Refer to the dimensions.	Non shorting	Reflow	13.0×3.5×3.5	—	6
SSSS213100	Horizontal	2.0	1	2	Refer to the dimensions.	Non shorting	Manual, Dip	9.0×3.5×3.5	—	7
SSSS212200	Horizontal	2.0	1	3	Refer to the dimensions.	Non shorting	Manual, Dip	13.0×3.5×3.5	—	8
SSSS212400	Horizontal	2.0	1	4	Refer to the dimensions.	Non shorting	Manual, Dip	15.0×3.5×3.5	—	9
SSSS223200	Horizontal	2.0	2	2	Refer to the dimensions.	Non shorting	Manual, Dip	9.0×3.5×3.5	—	10
SSSS223900	Horizontal	2.0	2	3	Refer to the dimensions.	Non shorting	Manual, Dip	13.0×3.5×3.5	—	11
SSSS224100	Horizontal	2.0	2	4	Refer to the dimensions.	Non shorting	Manual, Dip	15.0×3.5×3.5	—	12
SSSS211603	Horizontal	2.0	1	2	Refer to the dimensions.	Non shorting	Reflow	9.0×3.5×3.5	—	13
SSSS213800	Horizontal	2.0	1	3	Refer to the dimensions.	Non shorting	Reflow	13.0×3.5×3.5	—	14
SSSS224500	Horizontal	2.0	2	3	Refer to the dimensions.	Non shorting	Reflow	13.0×3.5×3.5	—	15

⚠ **Note**

1. This catalog shows only outline specifications. When using the products, please obtain formal specifications for supply.
2. Please place purchase orders per minimum order unit (integer).
3. Please place purchase orders for taping products per minimum order unit (1 reel or a case).

## ■ Packing Specifications

## Bulk

Products No.	Number of packages(pcs.)		Export package measurements (mm)
	1 case / Japan	1 case / export packing	
SSSS213000 SSSS211900 SSSS222700 SSSS223600 SSSS213100 SSSS212200 SSSS212400 SSSS223200 SSSS223900 SSSS224100	2,000	10,000	400 x 270 x 290

Switches Slide Switches

3.5 (H) mm, 2.0mm-travel  
SSSS2 Series

Taping

Products No.	Number of packages(pcs.)			Tape width (mm)	Export package measurements (mm)
	1 reel	1 case / Japan	1 case / export packing		
SSSS213202	1,200	2,400	4,800	24	428 x 413 x 172
SSSS212901	1,000	2,000	4,000	24	406 x 406 x 190
SSSS211603 SSSS213800 SSSS224500	1,400	2,800	5,600	24	406 x 406 x 190

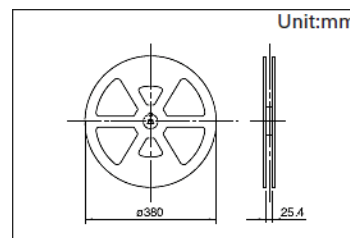

Drawing No.1

■ Dimensions

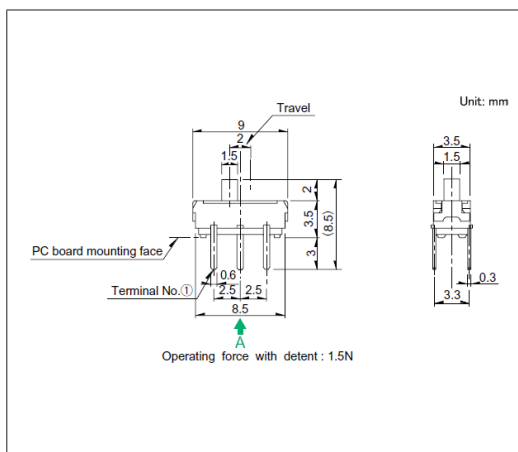

■ Mounting Hole Dimensions

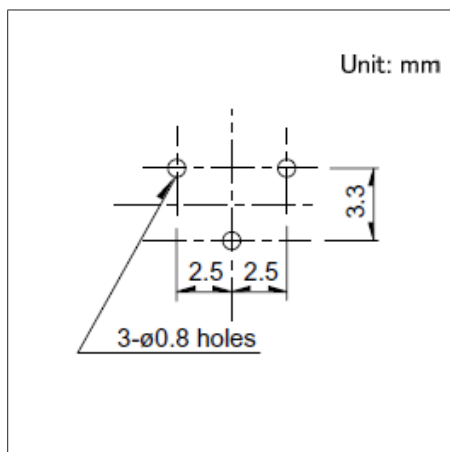

■ Circuit Diagram

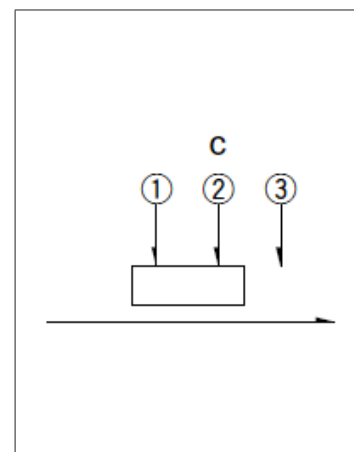

Viewed from direction A in the dimensions.

Drawing No.2

■ Dimensions

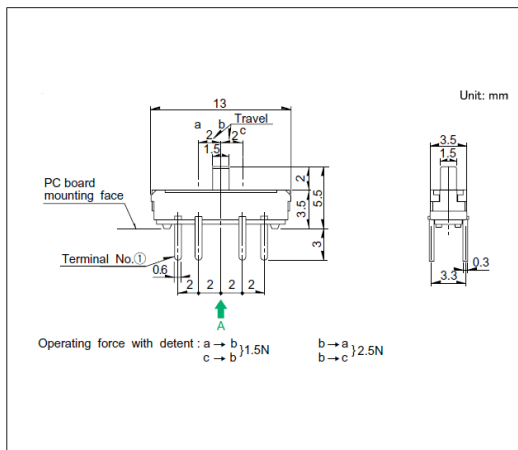

■ Mounting Hole Dimensions

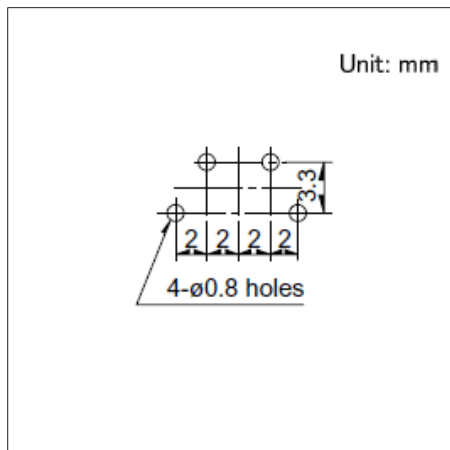

■ Circuit Diagram

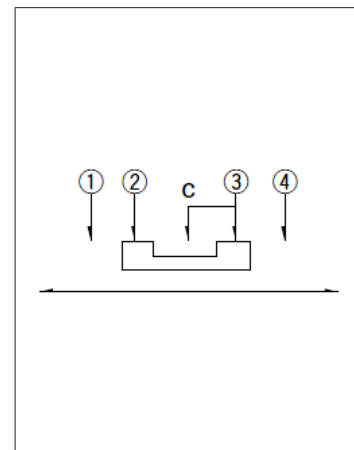

Viewed from direction A in the dimensions.

3.5 (H) mm, 2.0mm-travel  
SSSS2 Series

Drawing No.3

■ Dimensions

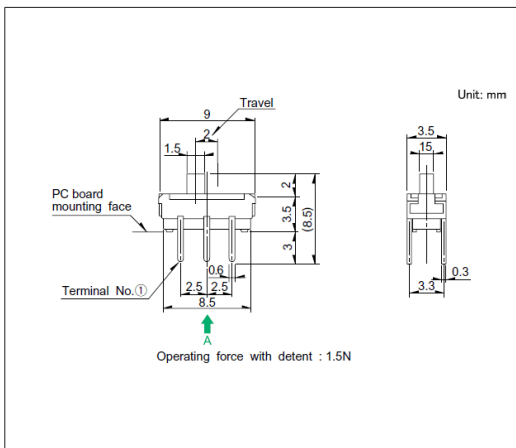

■ Mounting Hole Dimensions

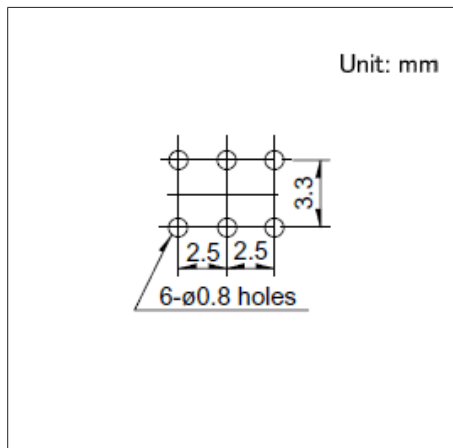

■ Circuit Diagram

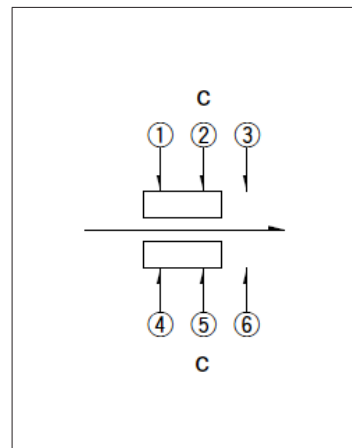

Viewed from direction A in the dimensions.

Drawing No.4

■ Dimensions

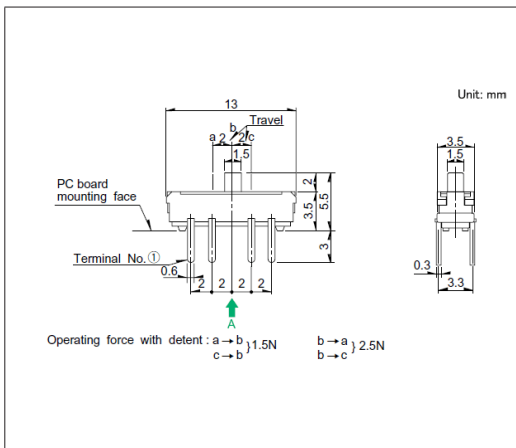

■ Mounting Hole Dimensions

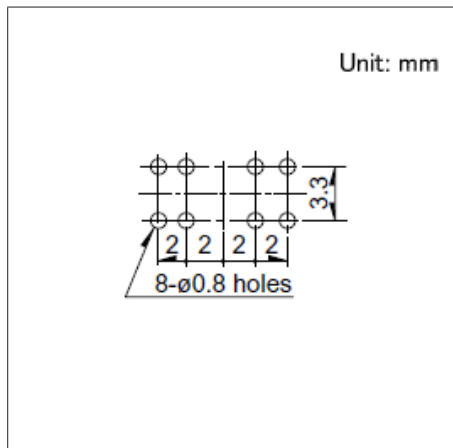

■ Circuit Diagram

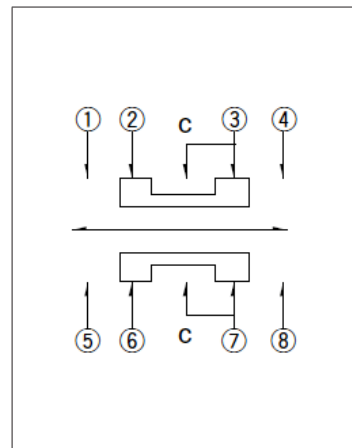

Viewed from direction A in the dimensions.

Drawing No.5

■ Dimensions

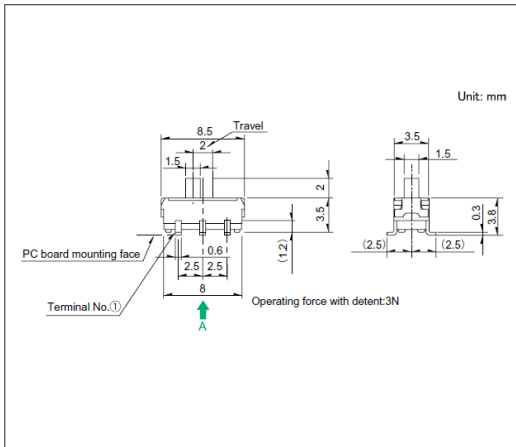

■ Land Dimensions

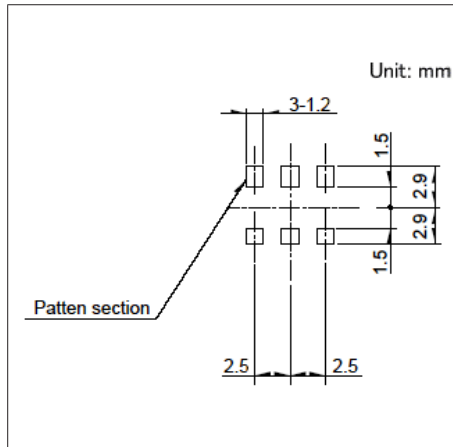

■ Circuit Diagram

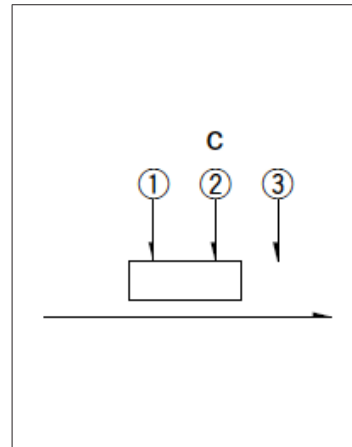

Viewed from direction A in the dimensions.

Switches Slide Switches

3.5 (H) mm, 2.0mm-travel  
SSSS2 Series

Drawing No.6

■ Dimensions

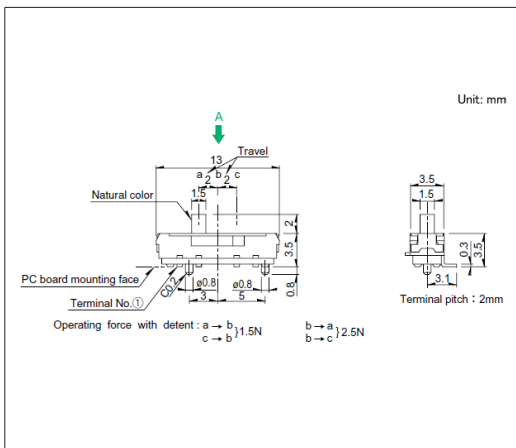

■ Land Dimensions

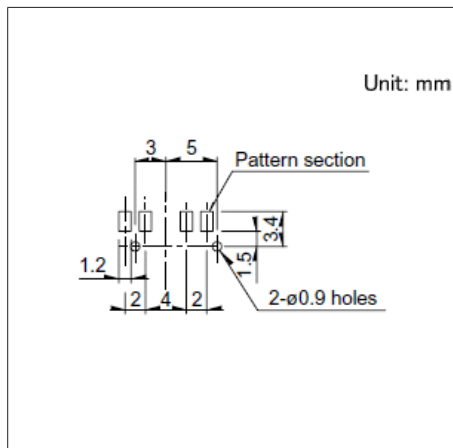

■ Circuit Diagram

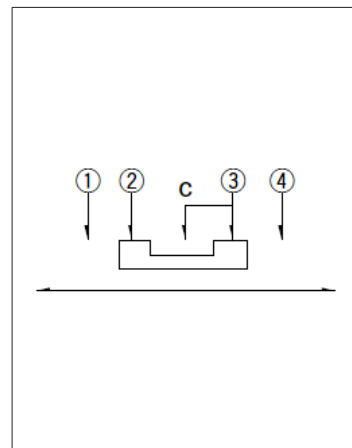

Viewed from direction A in the dimensions.

Drawing No.7

■ Dimensions

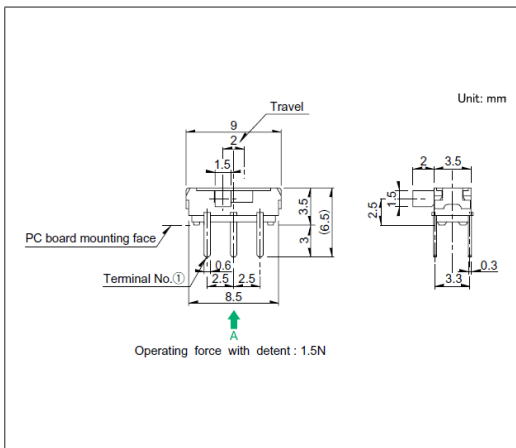

■ Mounting Hole Dimensions

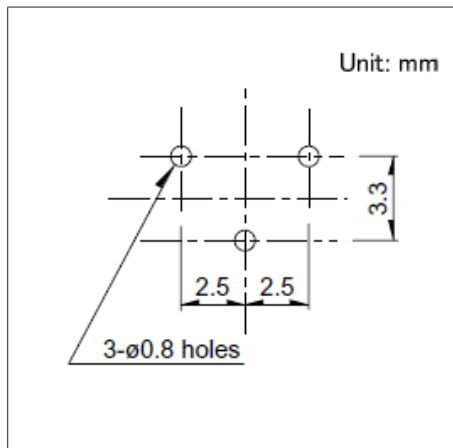

■ Circuit Diagram

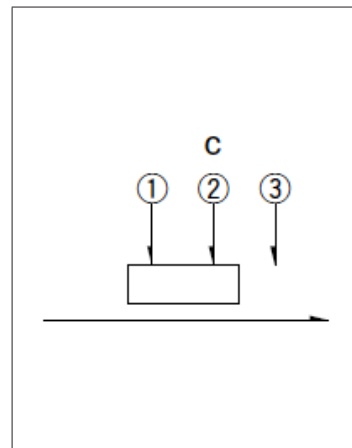

Viewed from direction A in the dimensions.

Drawing No.8

■ Dimensions

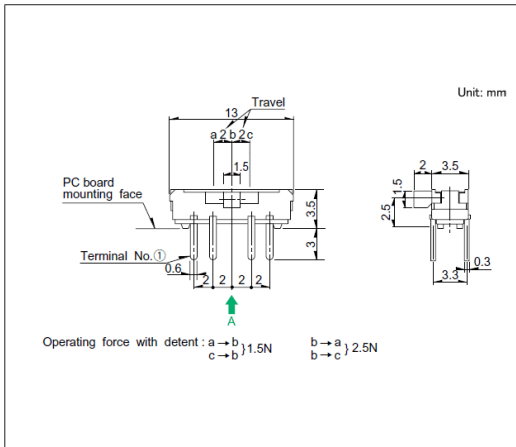

■ Mounting Hole Dimensions

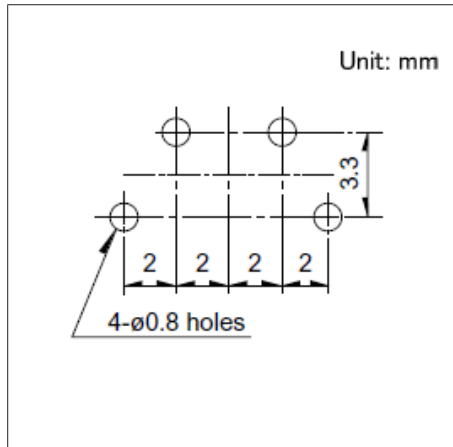

■ Circuit Diagram

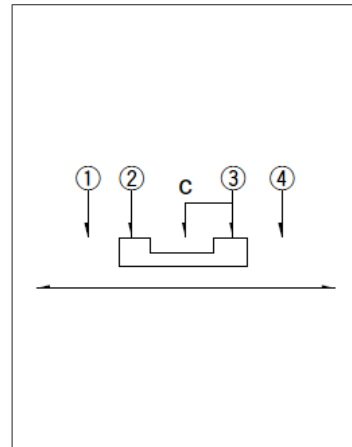

Viewed from direction A in the dimensions.

Switches Slide Switches

3.5 (H) mm, 2.0mm-travel  
SSSS2 Series

Drawing No.9

■ Dimensions

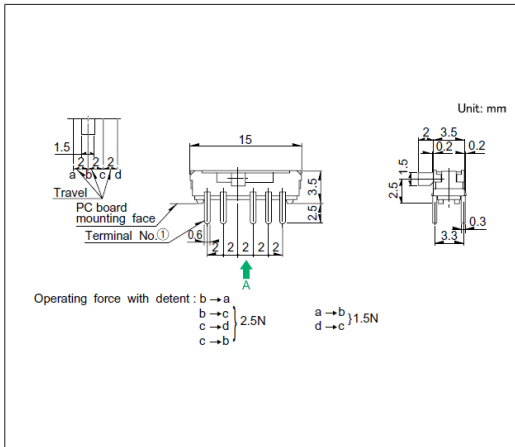

■ Mounting Hole Dimensions

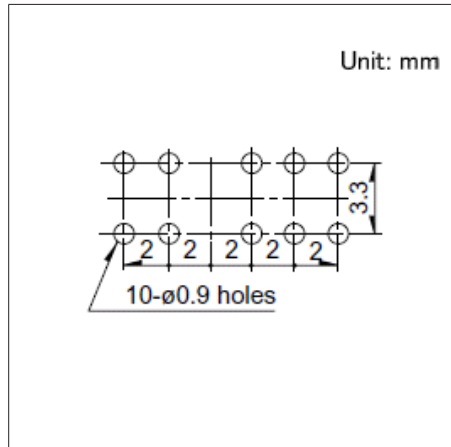

■ Circuit Diagram

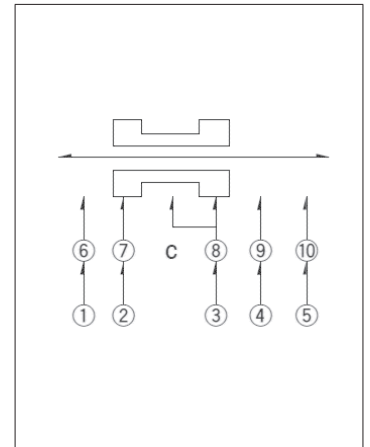

Viewed from direction A in the dimensions.

Drawing No.10

■ Dimensions

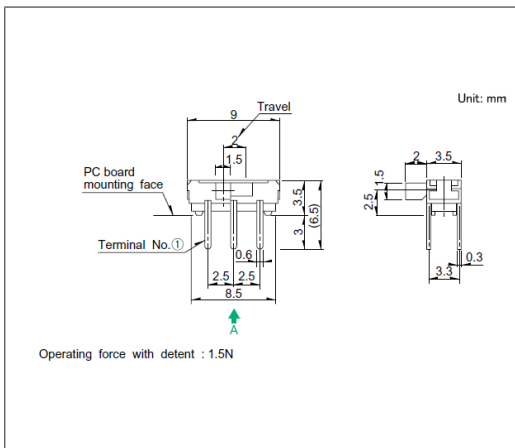

■ Mounting Hole Dimensions

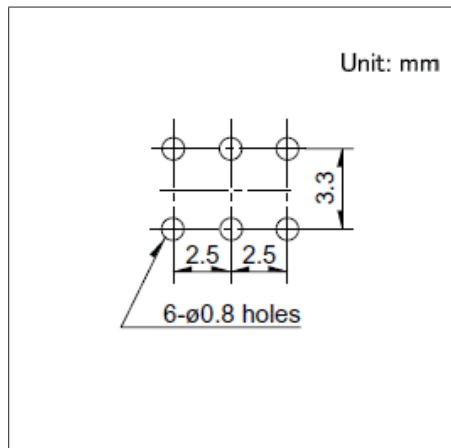

■ Circuit Diagram

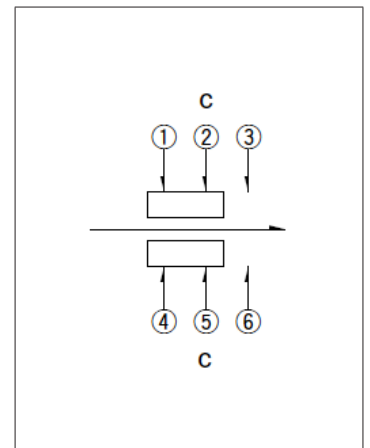

Viewed from direction A in the dimensions.

Drawing No.11

■ Dimensions

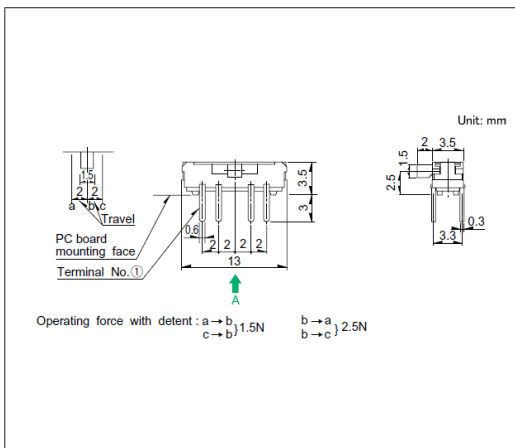

■ Mounting Hole Dimensions

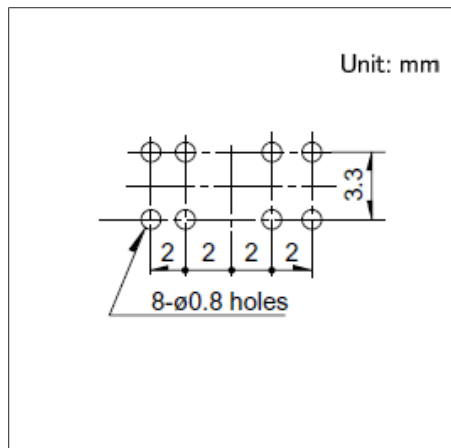

■ Circuit Diagram

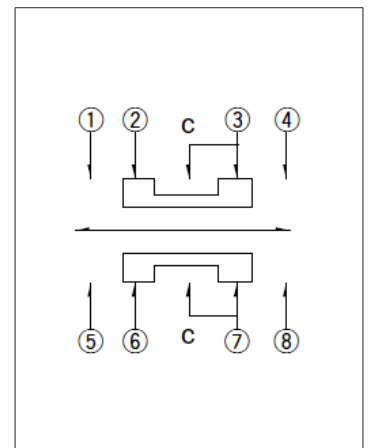

Viewed from direction A in the dimensions.



3.5 (H) mm, 2.0mm-travel  
**SSSS2 Series**

**Drawing No.15**

■ Dimensions

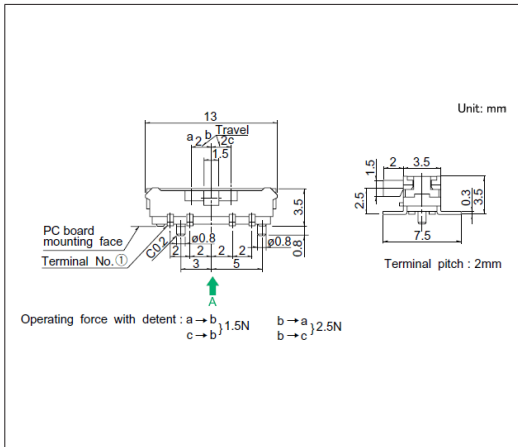

■ Land Dimensions

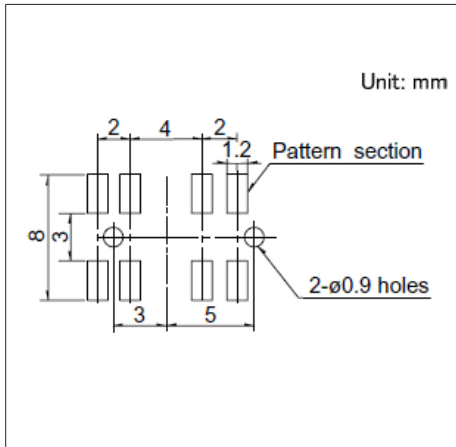

■ Circuit Diagram

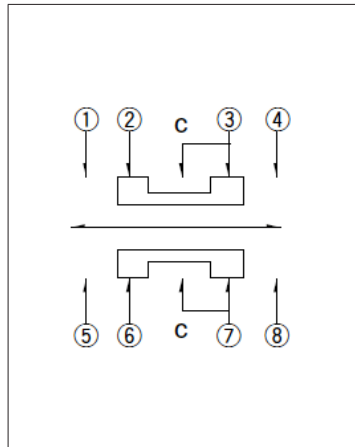

Viewed from direction A in the dimensions.

## Switches

## Slide Switches

5.0 (H) mm, 2.0mm-travel  
**SSSS9 Series**

Medium-sized general-purpose type well known for ease of use.

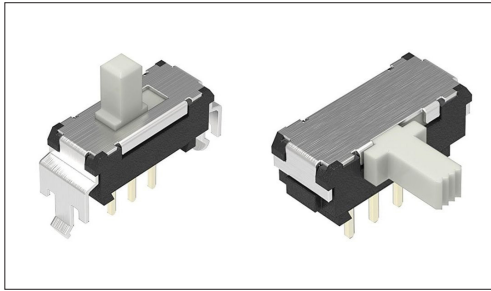

- Rating (max.)/(min.) (Resistive load): 0.1 A 12V DC/1mA 5V DC
- Contact resistance (Initial performance/After lifetime):  
30mΩ max./80mΩ max.
- Operating life without load: 10,000 cycles 60mΩ max.
- Operating life with load (at max. rated load): 10,000 cycles 80mΩ max.

Applications: Home: Major home appliances

## ■ Product List

Products No.	Actuator directions	Travel (mm)	Poles	Positions	Operating force	Changeover timing	Soldering	Dimensions (W×D×H) (mm)	Automotive	Drawing No.
SSSS912000	Vertical	2.0	1	2	3±1.5N	Non shorting	Manual, Dip	11.5×4.7×5.5	—	1
SSSS910400	Vertical	2.0	1	2	3±1.5N	Non shorting	Manual, Dip	11.5×4.7×5.5	—	2
SSSS919500	Vertical	2.0	1	3	a, c → b 2±1N b → a, c 3±1.5N	Not specified	Manual, Dip	14.0×4.7×5.5	—	3
SSSS918500	Vertical	2.0	1	3	a, c → b 2±1N b → a, c 3±1.5N	Not specified	Manual, Dip	14.0×4.7×5.5	—	4
SSSS922000	Vertical	2.0	2	2	3±1.5N	Non shorting	Manual, Dip	11.5×7.2×5.5	—	5
SSSS921800	Vertical	2.0	2	3	a, c → b 2±1N b → a, c 3±1.5N	Not specified	Manual, Dip	14.0×7.2×5.5	—	6
SSSS912500	Vertical	2.0	1	2	3±1.5N	Non shorting	Manual, Dip	11.5×4.7×5.5	—	7
SSSS910800	Vertical	2.0	1	2	3±1.5N	Non shorting	Manual, Dip	11.5×4.7×5.5	—	8
SSSS919800	Vertical	2.0	1	3	a, c → b 2±1N b → a, c 3±1.5N	Not specified	Manual, Dip	14.0×4.7×5.5	—	9
SSSS918700	Vertical	2.0	1	3	a, c → b 2±1N b → a, c 3±1.5N	Not specified	Manual, Dip	14.0×4.7×5.5	—	10
SSSS922500	Vertical	2.0	2	2	3±1.5N	Non shorting	Manual, Dip	11.5×7.2×5.5	—	11
SSSS923200	Vertical	2.0	2	3	a, c → b 2±1N b → a, c 3±1.5N	Not specified	Manual, Dip	14.0×7.2×5.5	—	12
SSSS920600	Vertical	2.0	2	3	a, c → b 2±1N b → a, c 3±1.5N	Not specified	Manual, Dip	14.0×7.2×5.5	—	13
SSSS916900	Horizontal	2.0	1	2	3±1.5N	Non shorting	Manual, Dip	11.5×4.7×5.0	—	14
SSSS915001	Horizontal	2.0	1	2	3±1.5N	Non shorting	Manual, Dip	11.5×4.7×5.0	—	15
SSSS91B900	Horizontal	2.0	1	3	a, c → b 2±1N b → a, c 3±1.5N	Not specified	Manual, Dip	14.0×4.7×5.0	—	16
SSSS926400	Horizontal	2.0	2	2	3±1.5N	Non shorting	Manual, Dip	11.5×7.2×5.0	—	17
SSSS928500	Horizontal	2.0	2	3	a, c → b 2±1N b → a, c 3±1.5N	Not specified	Manual, Dip	14.0×7.2×5.0	—	18
SSSS916400	Horizontal	2.0	1	2	3±1.5N	Non shorting	Manual, Dip	11.5×4.7×5.0	—	19
SSSS914503	Horizontal	2.0	1	2	3±1.5N	Non shorting	Manual, Dip	11.5×4.7×5.0	—	20
SSSS91B600	Horizontal	2.0	1	3	a, c → b 2±1N b → a, c 3±1.5N	Not specified	Manual, Dip	14.0×4.7×5.0	—	21
SSSS91A601	Horizontal	2.0	1	3	a, c → b 2±1N b → a, c 3±1.5N	Not specified	Manual, Dip	14.0×4.7×5.0	—	22
SSSS925800	Horizontal	2.0	2	2	3±1.5N	Non shorting	Manual, Dip	11.5×7.2×5.0	—	23
SSSS923802	Horizontal	2.0	2	2	3±1.5N	Non shorting	Manual, Dip	11.5×7.2×5.0	—	24
SSSS928200	Horizontal	2.0	2	3	a, c → b 2±1N b → a, c 3±1.5N	Not specified	Manual, Dip	14.0×7.2×5.0	—	25
SSSS925701	Horizontal	2.0	2	3	a, c → b 2±1N b → a, c 3±1.5N	Not specified	Manual, Dip	14.0×7.2×5.0	—	26

5.0 (H) mm, 2.0mm-travel  
**SSSS9 Series**

**Note**

1. This catalog shows only outline specifications. When using the products, please obtain formal specifications for supply.
2. Please place purchase orders per minimum order unit (integer).

■ Packing Specifications

Bulk

Products No.	Number of packages(pcs.)		Export package measurements (mm)
	1 case / Japan	1 case / export packing	
SSSS912000 SSSS910400 SSSS919500 SSSS918500 SSSS922000 SSSS912500 SSSS910800 SSSS919800 SSSS918700 SSSS922500 SSSS916900 SSSS915001 SSSS91B900 SSSS926400 SSSS916400 SSSS914503 SSSS91B600 SSSS91A601 SSSS925800 SSSS923802	1,000	5,000	400 x 270 x 290
SSSS921800 SSSS923200 SSSS920600 SSSS928500 SSSS928200 SSSS925701	800	4,000	400 x 270 x 290

Drawing No.1

■ Dimensions

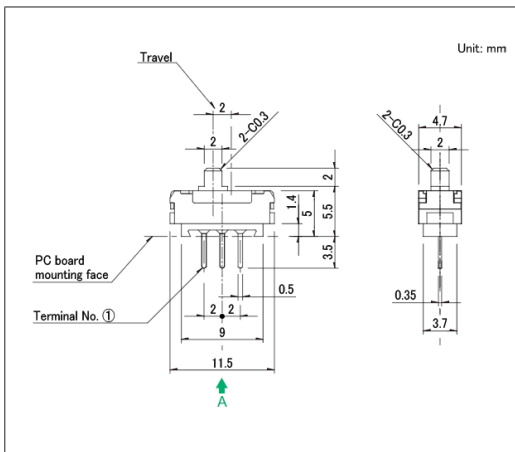

■ Mounting Hole Dimensions

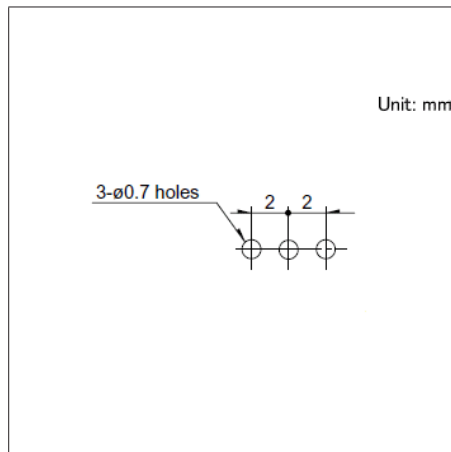

■ Circuit Diagram

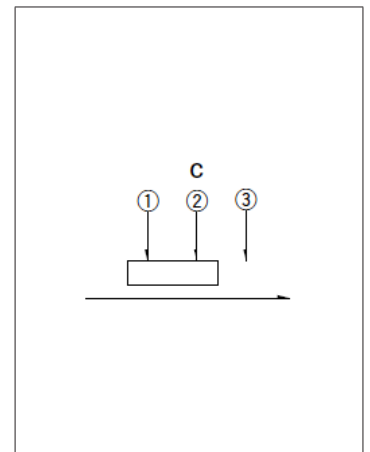

Viewed from direction A in the dimensions.

Switches Slide Switches

5.0 (H) mm, 2.0mm-travel  
SSSS9 Series

Drawing No.2

■ Dimensions

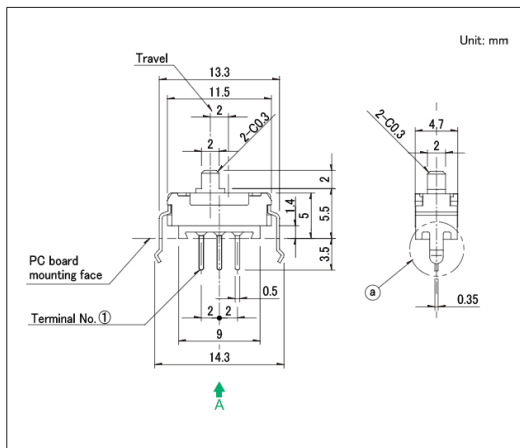

■ Mounting Hole Dimensions

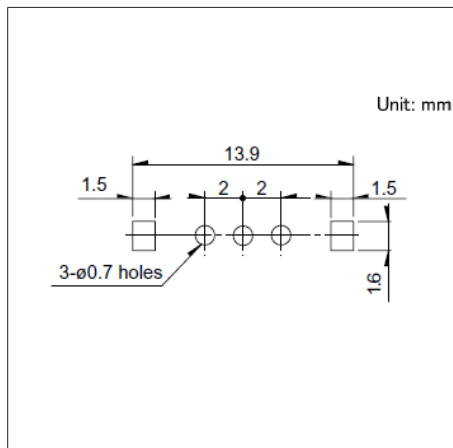

■ Circuit Diagram

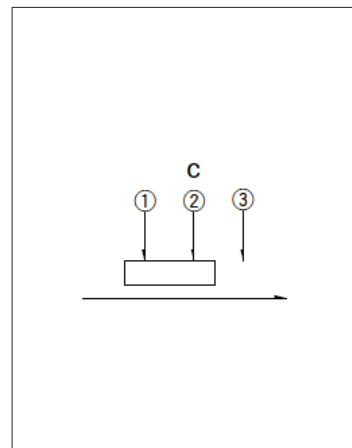

Viewed from direction A in the dimensions.

Drawing No.3

■ Dimensions

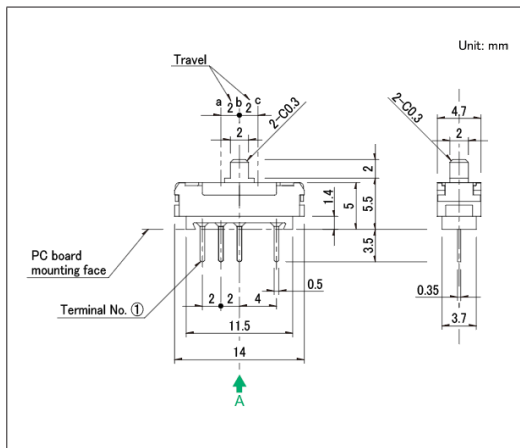

■ Mounting Hole Dimensions

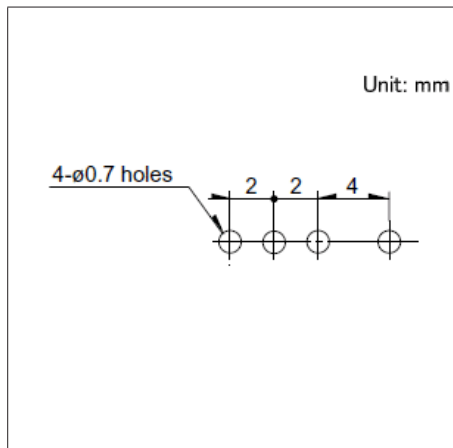

■ Circuit Diagram

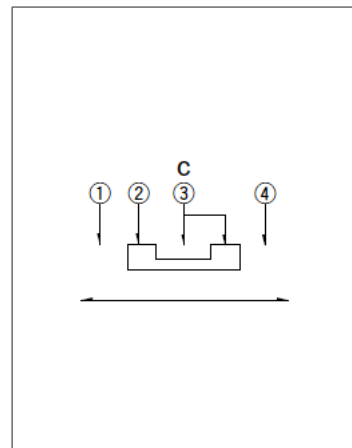

Viewed from direction A in the dimensions.

Drawing No.4

■ Dimensions

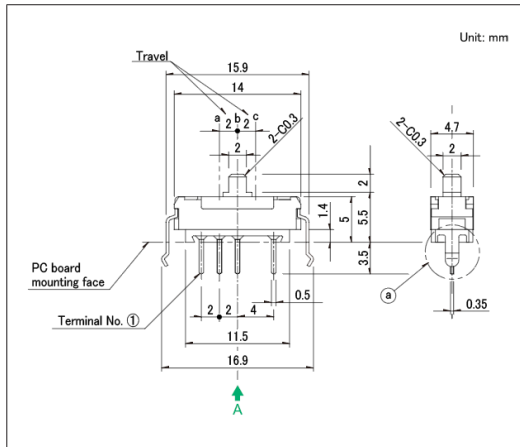

■ Mounting Hole Dimensions

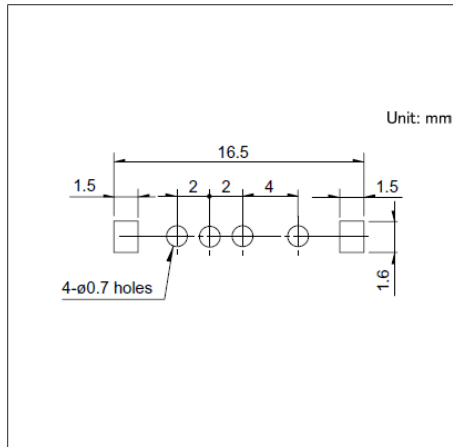

■ Circuit Diagram

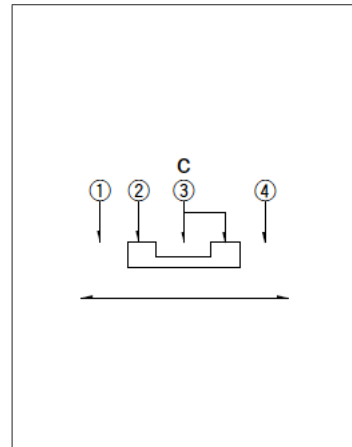

Viewed from direction A in the dimensions.

Switches Slide Switches

5.0 (H) mm, 2.0mm-travel  
SSSS9 Series

Drawing No.5

■ Dimensions

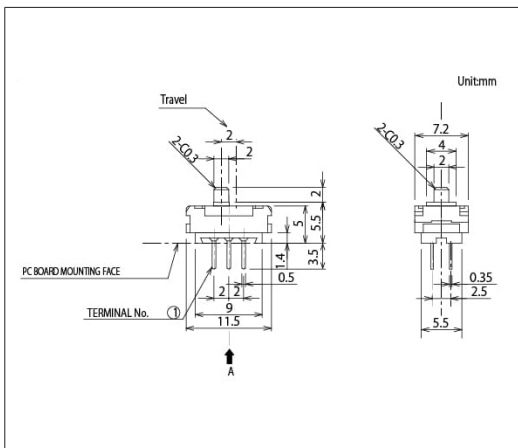

■ Mounting Hole Dimensions

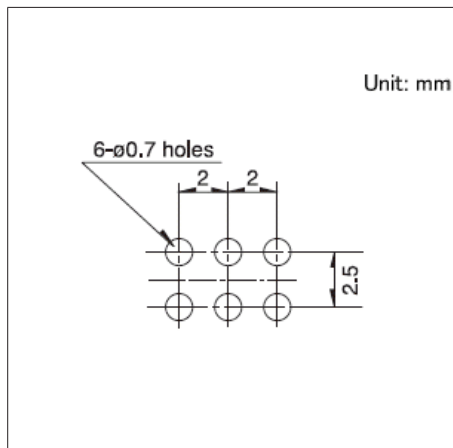

■ Circuit Diagram

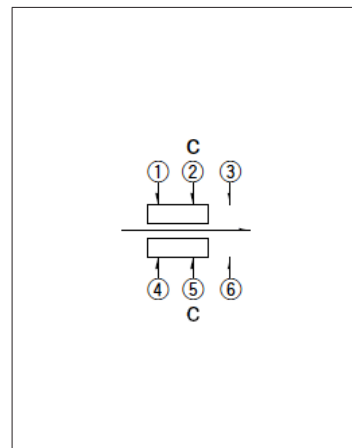

Viewed from direction A in the dimensions.

Drawing No.6

■ Dimensions

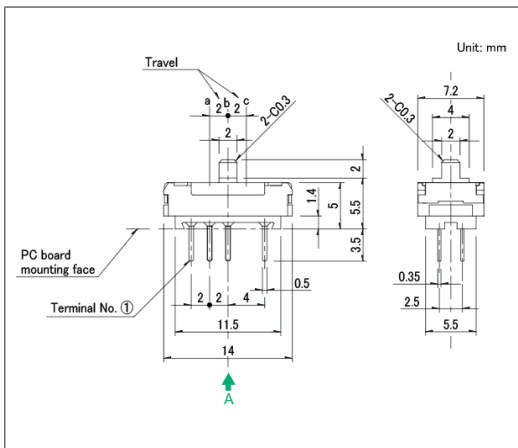

■ Mounting Hole Dimensions

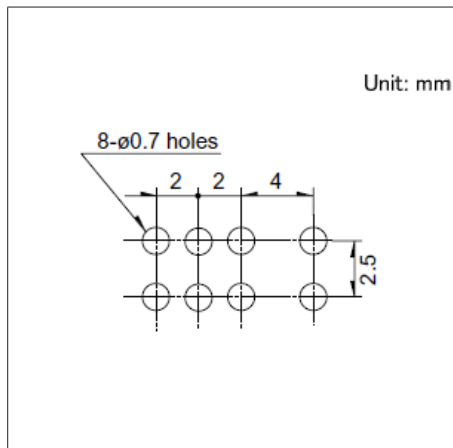

■ Circuit Diagram

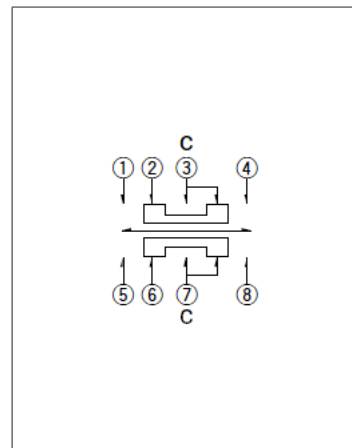

Viewed from direction A in the dimensions.

Drawing No.7

■ Dimensions

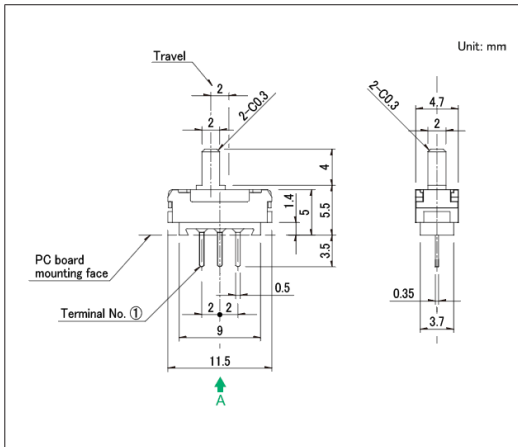

■ Mounting Hole Dimensions

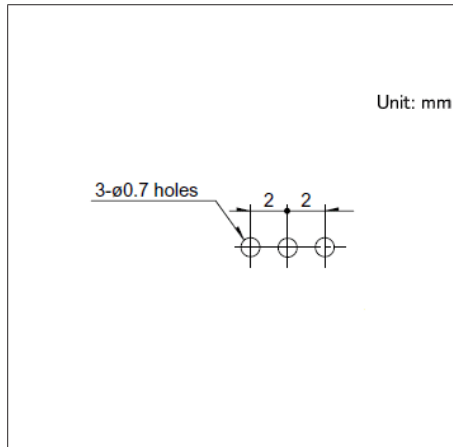

■ Circuit Diagram

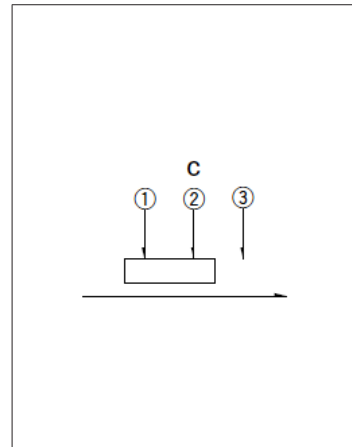

Viewed from direction A in the dimensions.



5.0 (H) mm, 2.0mm-travel  
SSSS9 Series

Drawing No.11

■ Dimensions

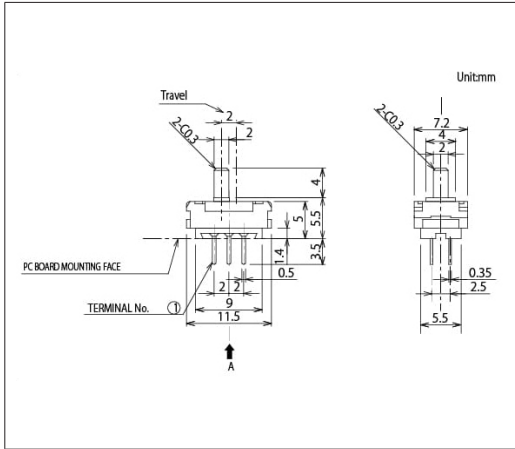

■ Mounting Hole Dimensions

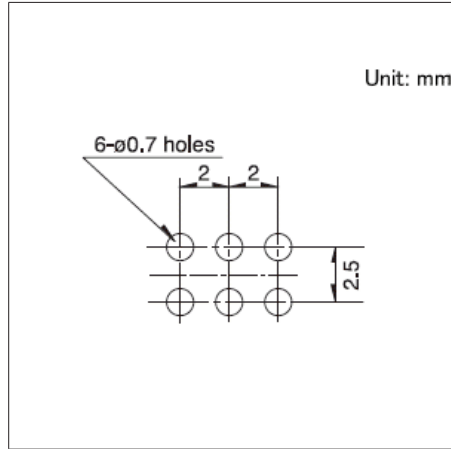

■ Circuit Diagram

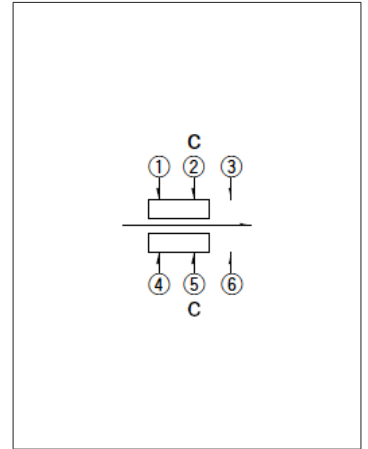

Viewed from direction A in the dimensions.

Drawing No.12

■ Dimensions

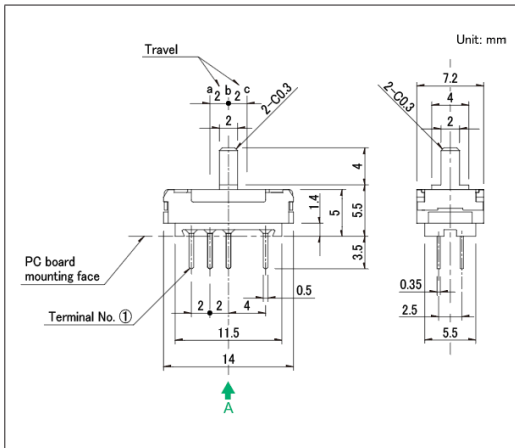

■ Mounting Hole Dimensions

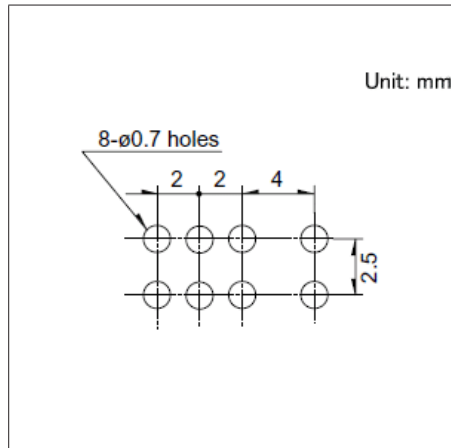

■ Circuit Diagram

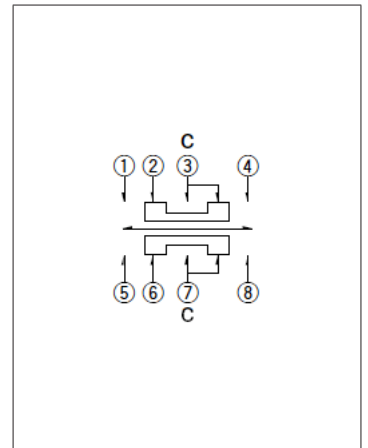

Viewed from direction A in the dimensions.

Drawing No.13

■ Dimensions

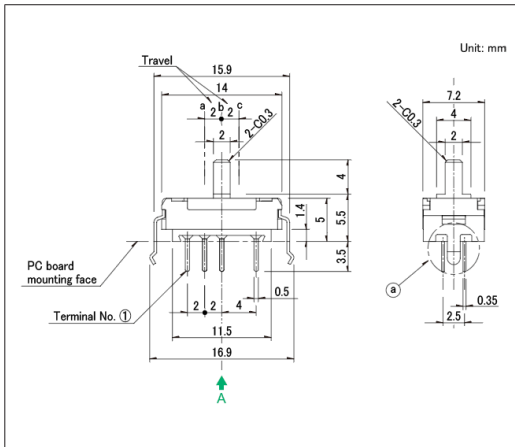

■ Mounting Hole Dimensions

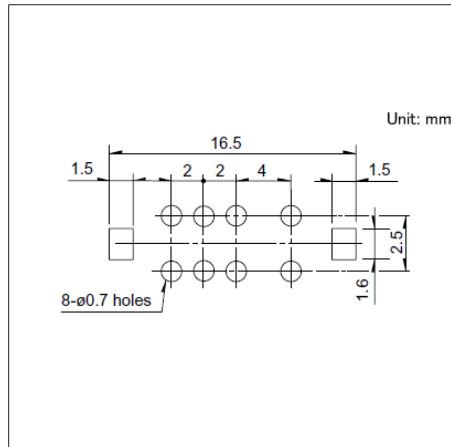

■ Circuit Diagram

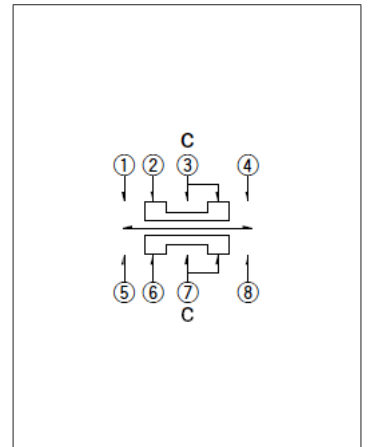

Viewed from direction A in the dimensions.





Switches Slide Switches

5.0 (H) mm, 2.0mm-travel  
SSSS9 Series

Drawing No.20

■ Dimensions

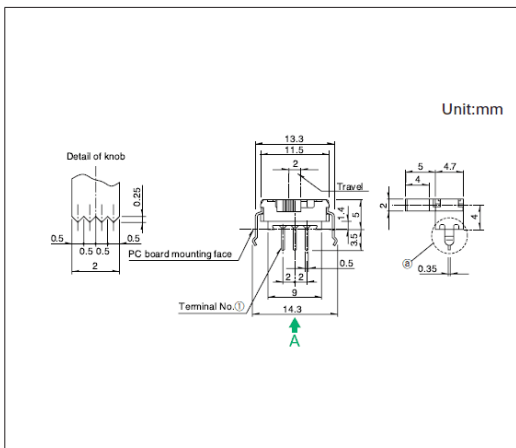

■ Mounting Hole Dimensions

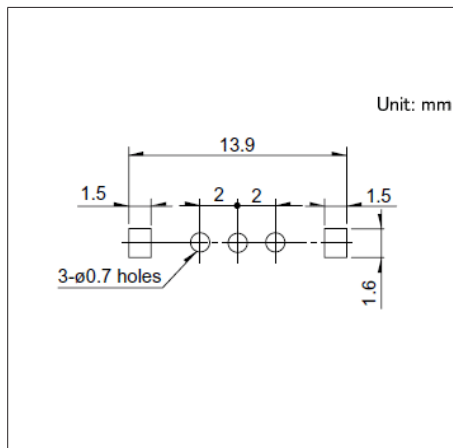

■ Circuit Diagram

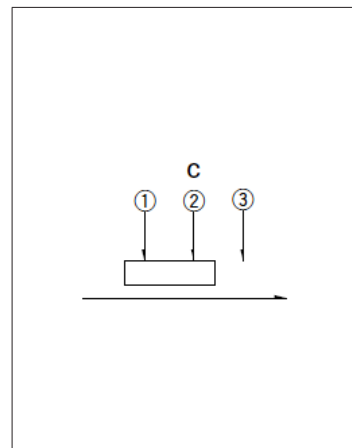

Viewed from direction A in the dimensions.

Drawing No.21

■ Dimensions

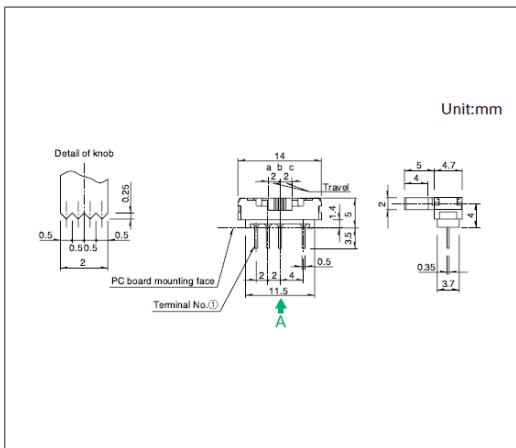

■ Mounting Hole Dimensions

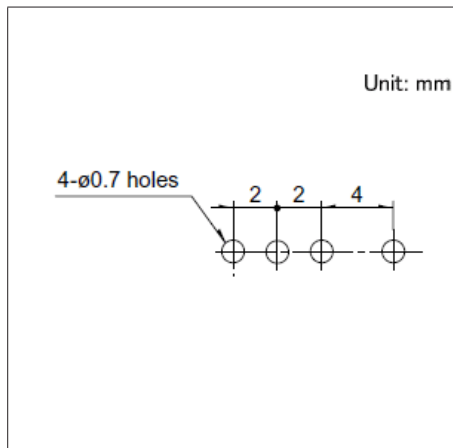

■ Circuit Diagram

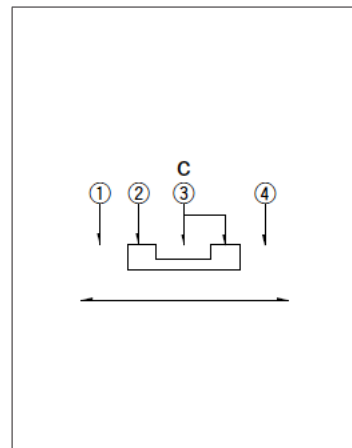

Viewed from direction A in the dimensions.

Drawing No.22

■ Dimensions

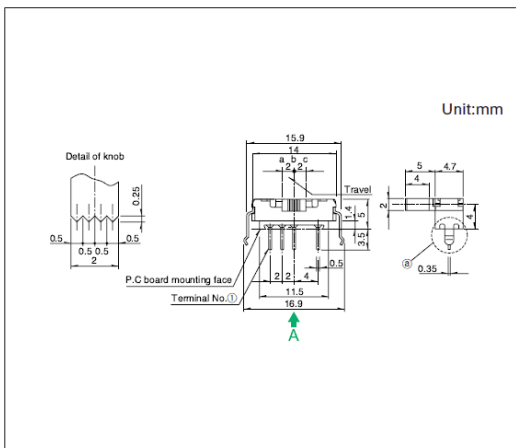

■ Mounting Hole Dimensions

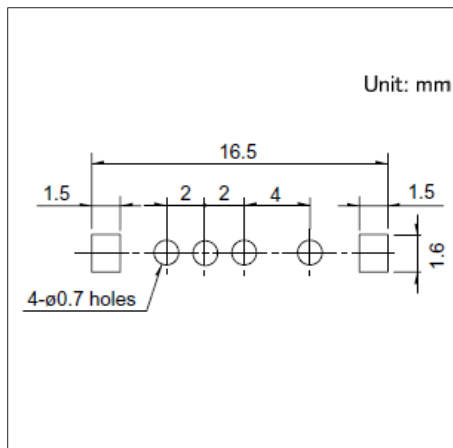

■ Circuit Diagram

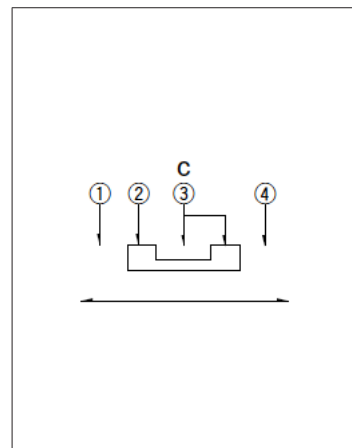

Viewed from direction A in the dimensions.

Switches Slide Switches

5.0 (H) mm, 2.0mm-travel  
SSSS9 Series

Drawing No.23

■ Dimensions

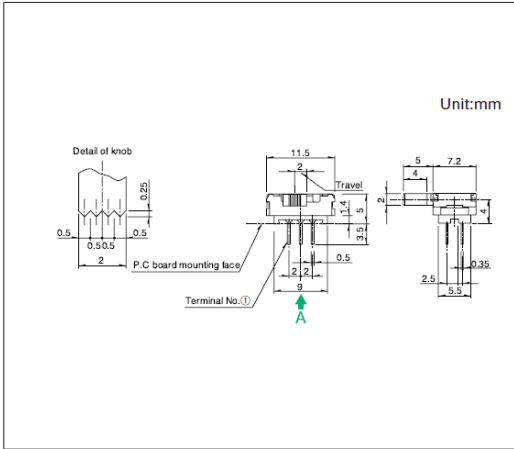

■ Mounting Hole Dimensions

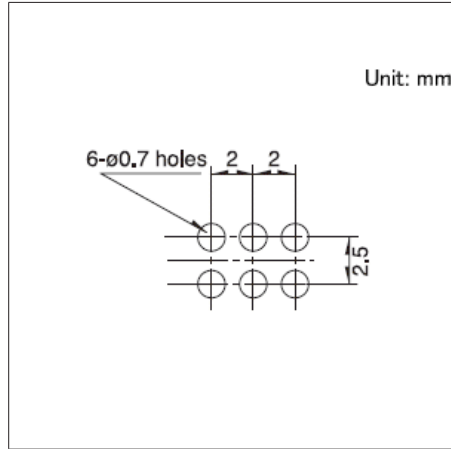

■ Circuit Diagram

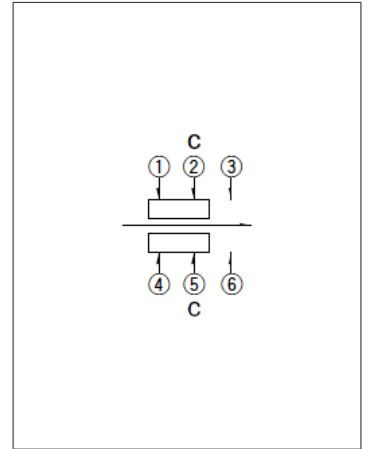

Viewed from direction A in the dimensions.

Drawing No.24

■ Dimensions

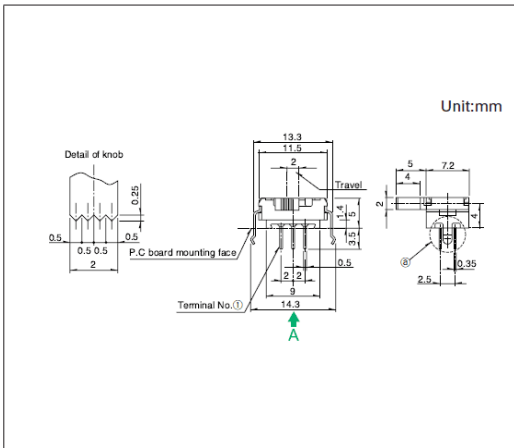

■ Mounting Hole Dimensions

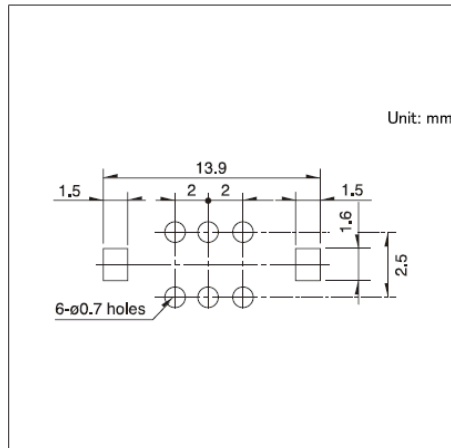

■ Circuit Diagram

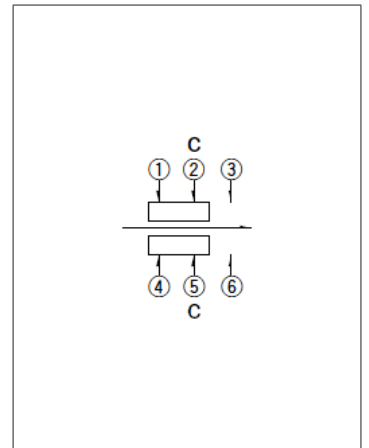

Viewed from direction A in the dimensions.

Drawing No.25

■ Dimensions

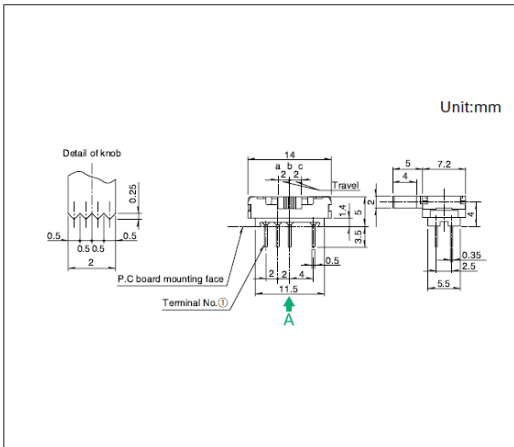

■ Mounting Hole Dimensions

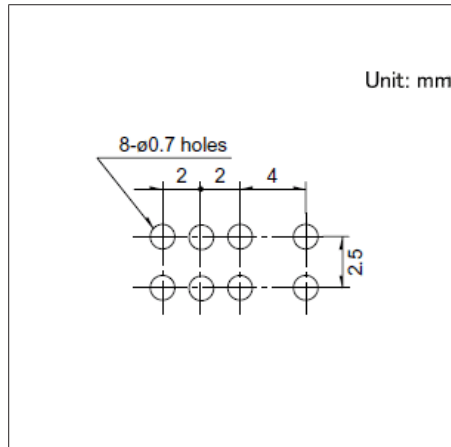

■ Circuit Diagram

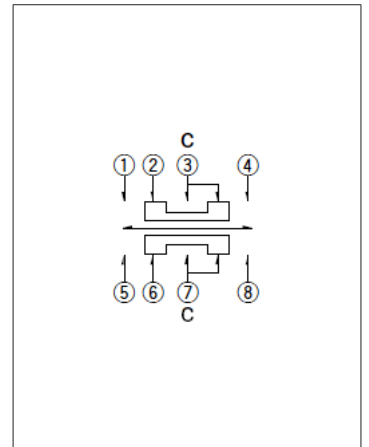

Viewed from direction A in the dimensions.

5.0 (H) mm, 2.0mm-travel  
**SSSS9 Series**

**Drawing No.26**

■ Dimensions

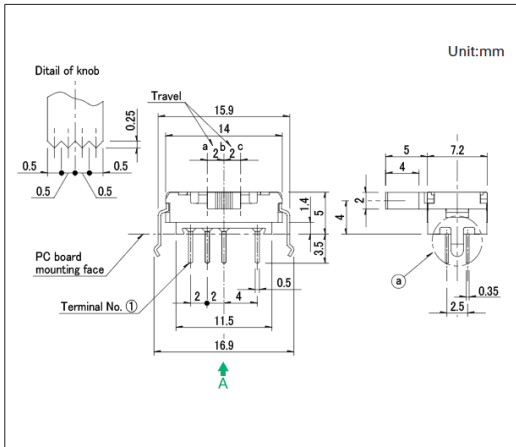

■ Mounting Hole Dimensions

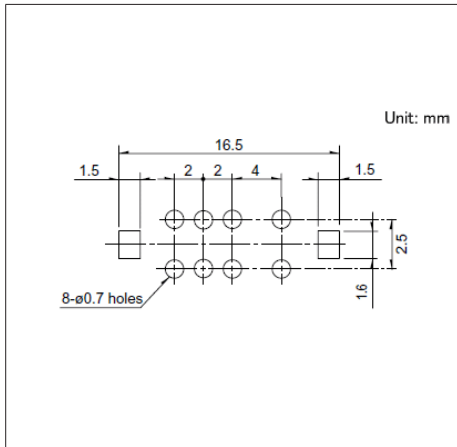

■ Circuit Diagram

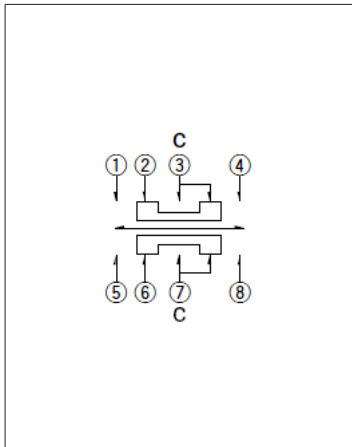

Viewed from direction A in the dimensions.

8.5 (H) mm, 2.0mm-travel

**SSSF Series**

Large general-purpose type with a proven track record across diverse industries.

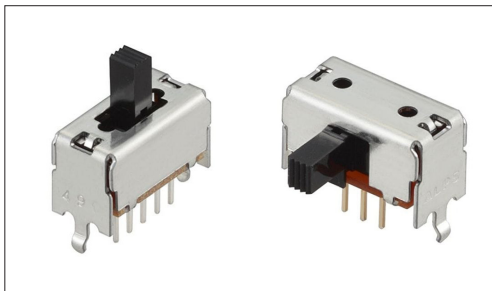

- Rating (max.)/(min.) (Resistive load): 0.1 A 30V DC/50 $\mu$ A 3V DC
- Contact resistance (Initial performance/After lifetime):  
25m $\Omega$  max./65m $\Omega$  max.
- Operating life without load: 10,000 cycles 45m $\Omega$  max.
- Operating life with load (at max. rated load): 10,000 cycles 65m $\Omega$  max.

Applications: Audio\_TV: Audio

## ■ Product List

Products No.	Actuator directions	Travel (mm)	Poles	Positions	Operating force	Changeover timing	Soldering	Dimensions (W×D×H) (mm)	Automotive	Drawing No.
SSSF011700	Vertical	2.0	1	2	Refer to the dimensions.	Non shorting	Manual, Dip	14.5×7.0×8.5	—	1
SSSF012100	Vertical	2.0	1	2	Refer to the dimensions.	Non shorting	Manual, Dip	14.5×7.0×8.5	—	2
SSSF014800	Vertical	2.0	1	3	Refer to the dimensions.	Non shorting	Manual, Dip	14.5×7.0×8.5	—	3
SSSF021500	Vertical	2.0	2	2	Refer to the dimensions.	Non shorting	Manual, Dip	14.5×7.0×8.5	—	4
SSSF021900	Vertical	2.0	2	2	Refer to the dimensions.	Non shorting	Manual, Dip	14.5×7.0×8.5	—	5
SSSF024800	Vertical	2.0	2	3	Refer to the dimensions.	Non shorting	Manual, Dip	14.5×7.0×8.5	—	6
SSSF025100	Vertical	2.0	2	3	Refer to the dimensions.	Non shorting	Manual, Dip	14.5×7.0×8.5	—	7
SSSF040800	Vertical	2.0	4	2	Refer to the dimensions.	Non shorting	Manual, Dip	16.5×7.0×8.5	—	8
SSSF111800	Horizontal	2.0	1	2	Refer to the dimensions.	Non shorting	Manual, Dip	14.5×7.0×8.5	—	9
SSSF112500	Horizontal	2.0	1	2	Refer to the dimensions.	Non shorting	Manual, Dip	14.5×7.0×8.5	—	10
SSSF114900	Horizontal	2.0	1	3	Refer to the dimensions.	Non shorting	Manual, Dip	14.5×7.0×8.5	—	11
SSSF115300	Horizontal	2.0	1	3	Refer to the dimensions.	Non shorting	Manual, Dip	14.5×7.0×8.5	—	12
SSSF121900	Horizontal	2.0	2	2	Refer to the dimensions.	Non shorting	Manual, Dip	14.5×7.0×8.5	—	13
SSSF122400	Horizontal	2.0	2	2	Refer to the dimensions.	Non shorting	Manual, Dip	14.5×7.0×8.5	—	14
SSSF125300	Horizontal	2.0	2	3	Refer to the dimensions.	Non shorting	Manual, Dip	14.5×7.0×8.5	—	15
SSSF125800	Horizontal	2.0	2	3	Refer to the dimensions.	Non shorting	Manual, Dip	14.5×7.0×8.5	—	16
SSSF141000	Horizontal	2.0	4	2	Refer to the dimensions.	Non shorting	Manual, Dip	16.5×7.0×8.5	—	17
SSSF141300	Horizontal	2.0	4	2	Refer to the dimensions.	Non shorting	Manual, Dip	16.5×7.0×8.5	—	18

## ⚠ Note

1. This catalog shows only outline specifications. When using the products, please obtain formal specifications for supply.
2. Please place purchase orders per minimum order unit (integer).

Switches Slide Switches

8.5 (H) mm, 2.0mm-travel  
SSSF Series

■ Packing Specifications

Bulk

Products No.	Number of packages (pcs.)		Export package measurements (mm)
	1 case / Japan	1 case / export packing	
SSSF011700 SSSF012100 SSSF014800 SSSF021500 SSSF021900 SSSF024800 SSSF025100 SSSF040800 SSSF112500 SSSF115300 SSSF122400 SSSF125800 SSSF141000 SSSF141300	800	4,000	400 x 270 x 290
SSSF111800 SSSF114900 SSSF121900 SSSF125300	600	3,000	400 x 270 x 290

Drawing No.1

■ Dimensions

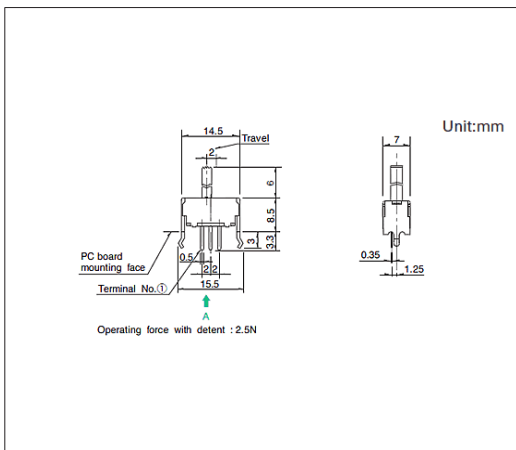

■ Mounting Hole Dimensions

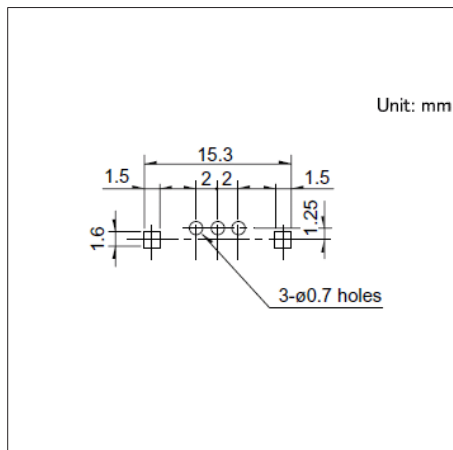

■ Circuit Diagram

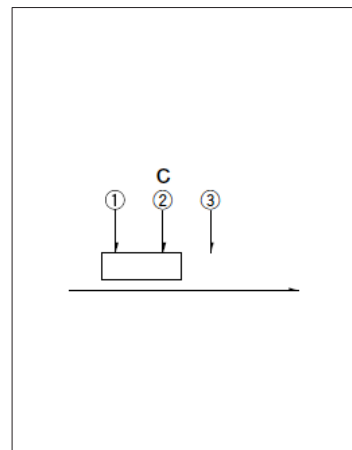

Viewed from direction A in the dimensions.

Drawing No.2

■ Dimensions

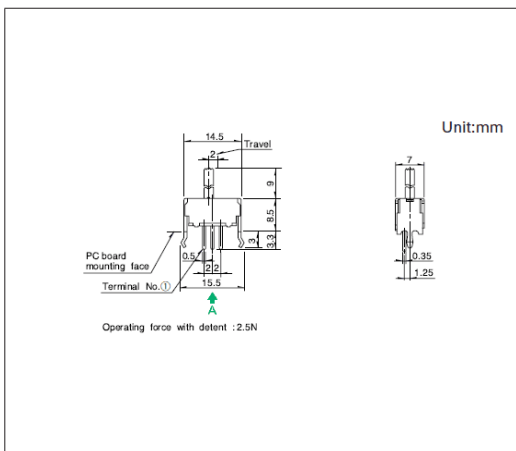

■ Mounting Hole Dimensions

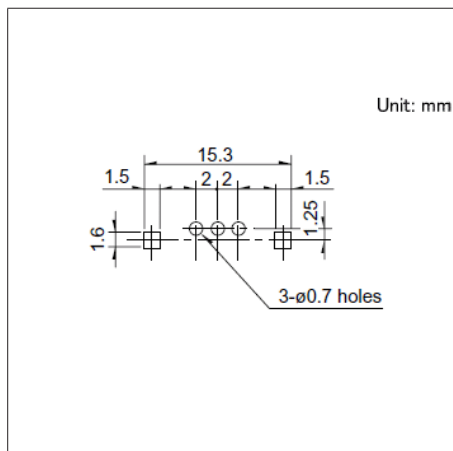

■ Circuit Diagram

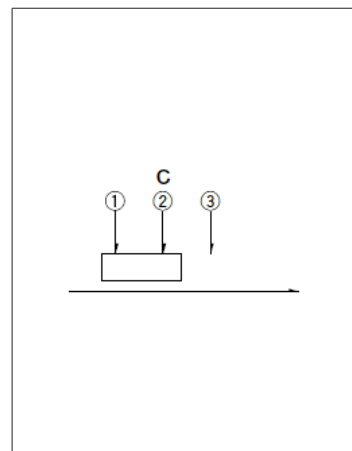

Viewed from direction A in the dimensions.

8.5 (H) mm, 2.0mm-travel  
SSSF Series

Drawing No.3

■ Dimensions

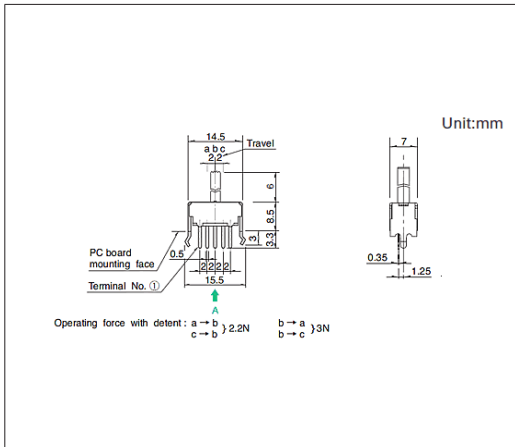

■ Mounting Hole Dimensions

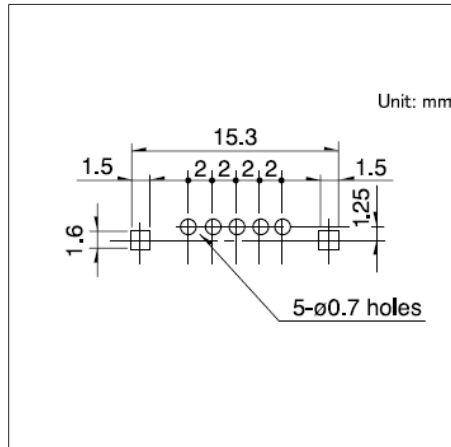

■ Circuit Diagram

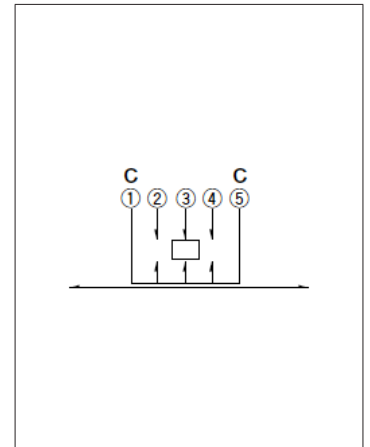

Viewed from direction A in the dimensions.

Drawing No.4

■ Dimensions

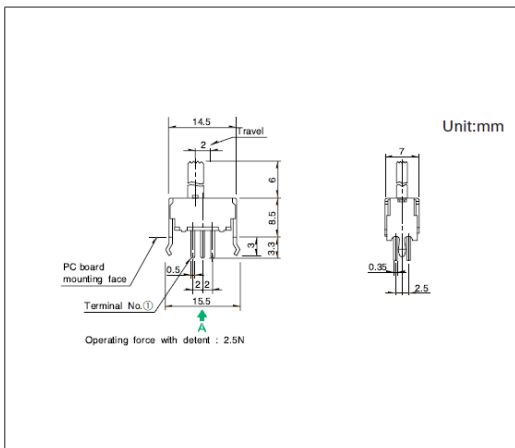

■ Mounting Hole Dimensions

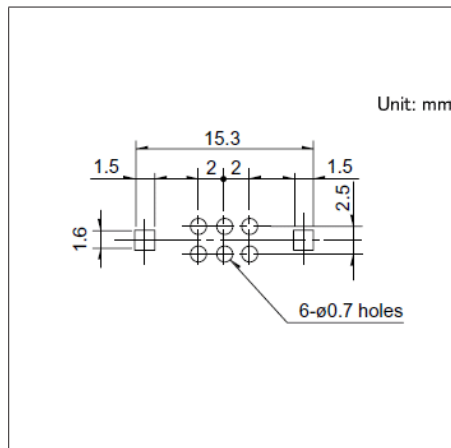

■ Circuit Diagram

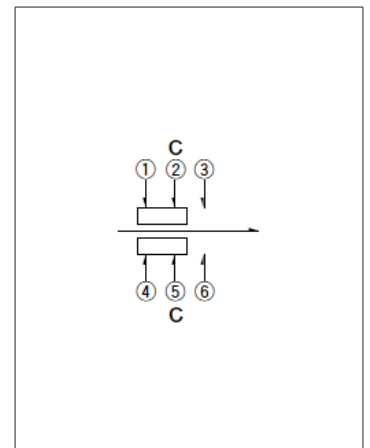

Viewed from direction A in the dimensions.

Drawing No.5

■ Dimensions

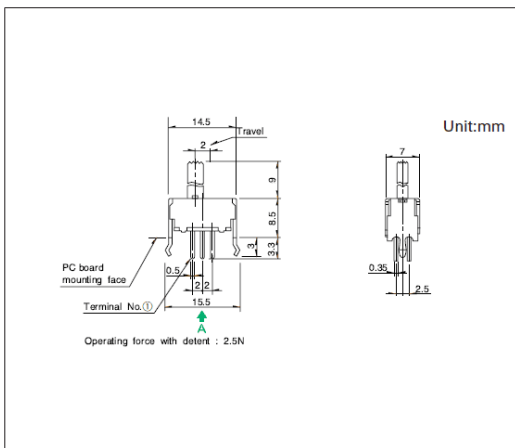

■ Mounting Hole Dimensions

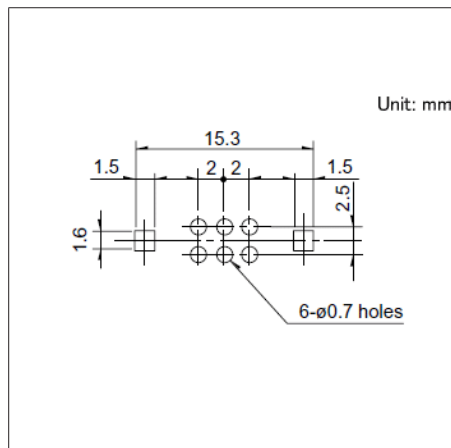

■ Circuit Diagram

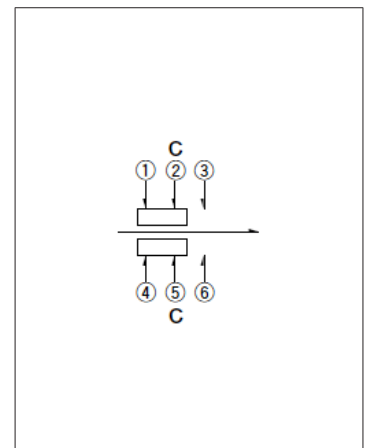

Viewed from direction A in the dimensions.

8.5 (H) mm, 2.0mm-travel  
SSSF Series

Drawing No.6

■ Dimensions

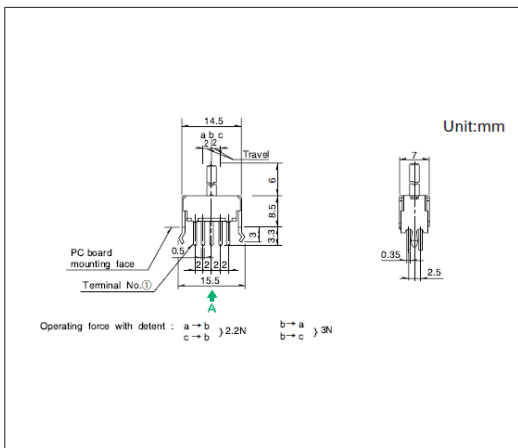

■ Mounting Hole Dimensions

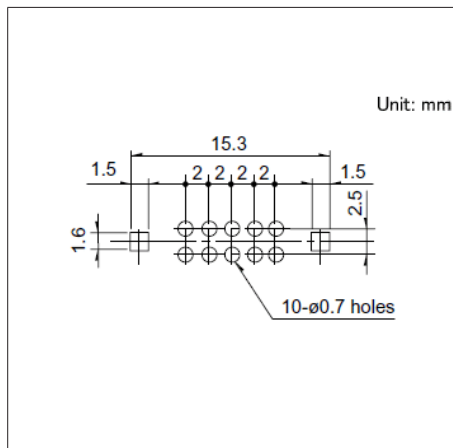

■ Circuit Diagram

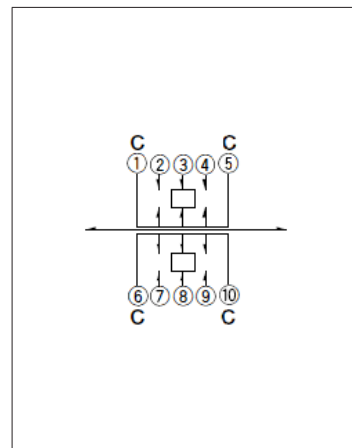

Viewed from direction A in the dimensions.

Drawing No.7

■ Dimensions

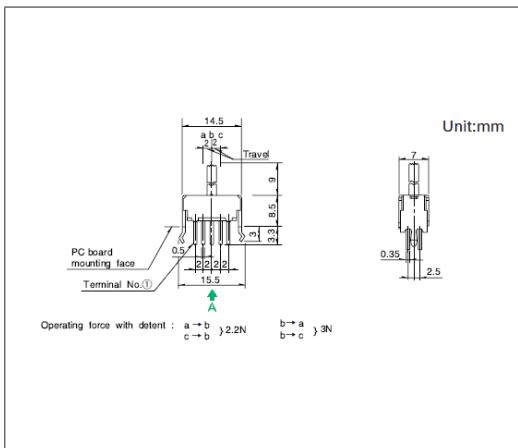

■ Mounting Hole Dimensions

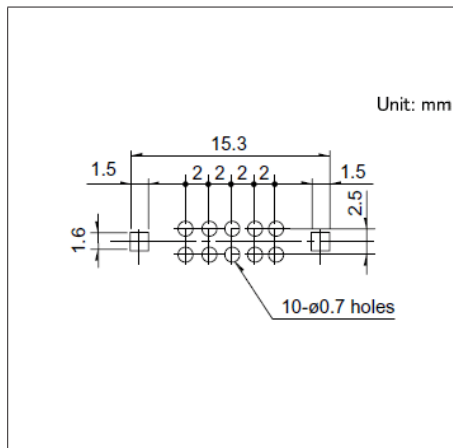

■ Circuit Diagram

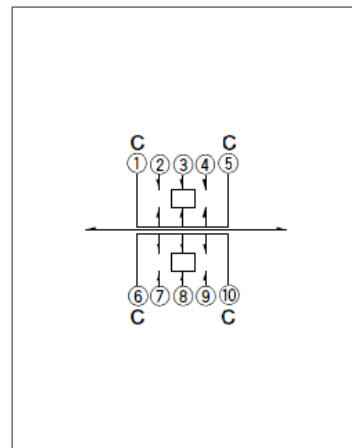

Viewed from direction A in the dimensions.

Drawing No.8

■ Dimensions

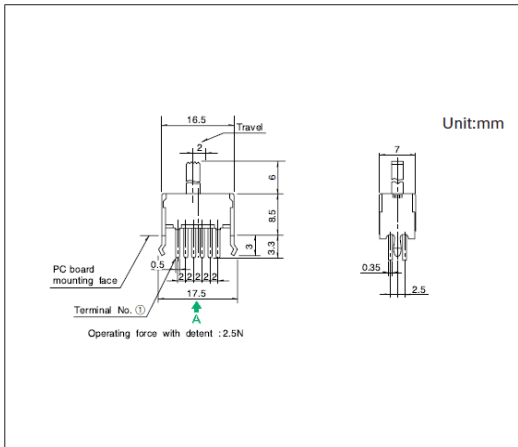

■ Mounting Hole Dimensions

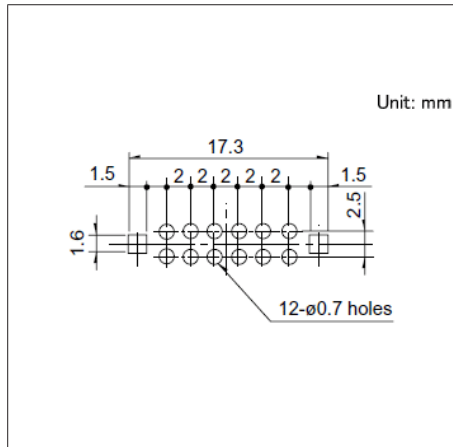

■ Circuit Diagram

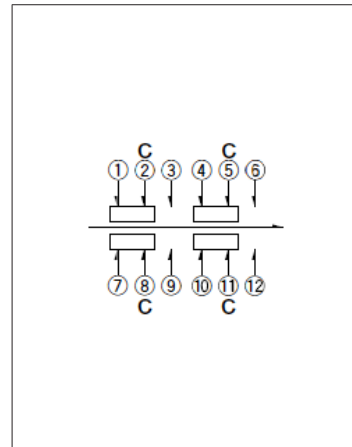

Viewed from direction A in the dimensions.

Drawing No.9

■ Dimensions

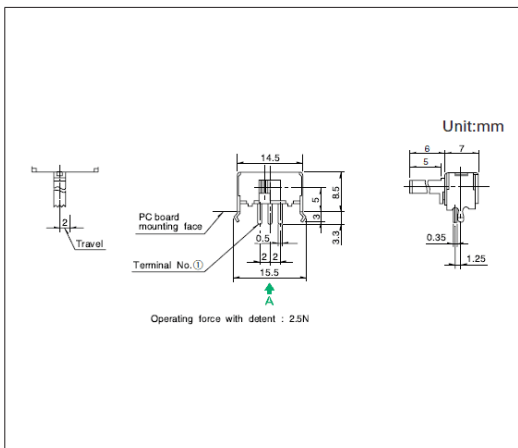

■ Mounting Hole Dimensions

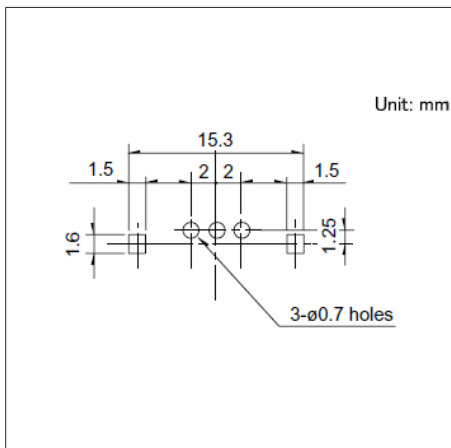

■ Circuit Diagram

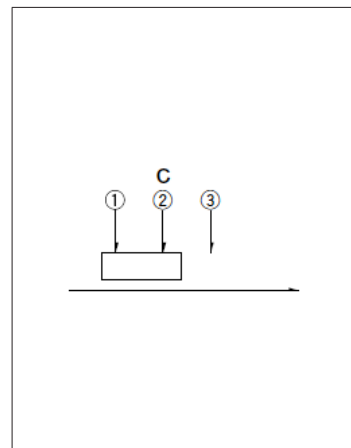

Viewed from direction A in the dimensions.

Drawing No.10

■ Dimensions

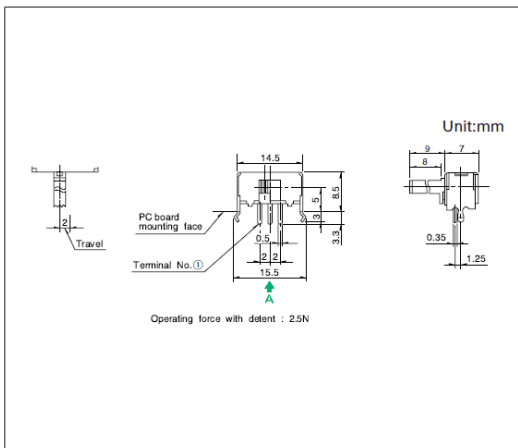

■ Mounting Hole Dimensions

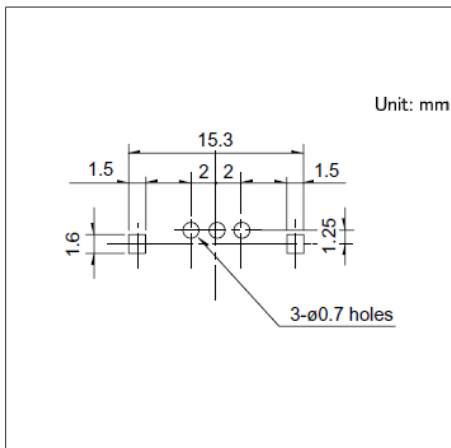

■ Circuit Diagram

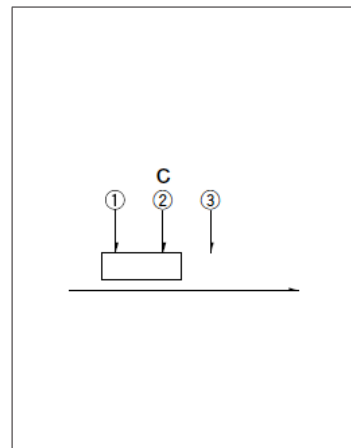

Viewed from direction A in the dimensions.

Drawing No.11

■ Dimensions

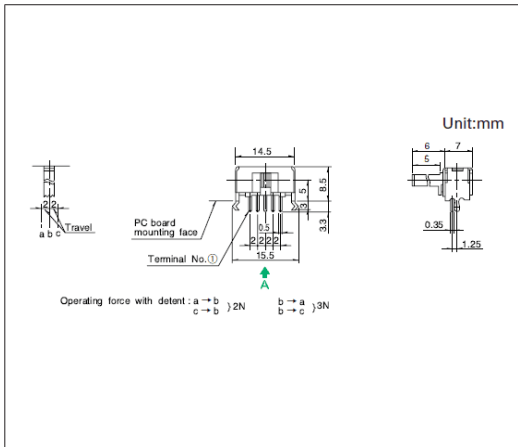

■ Mounting Hole Dimensions

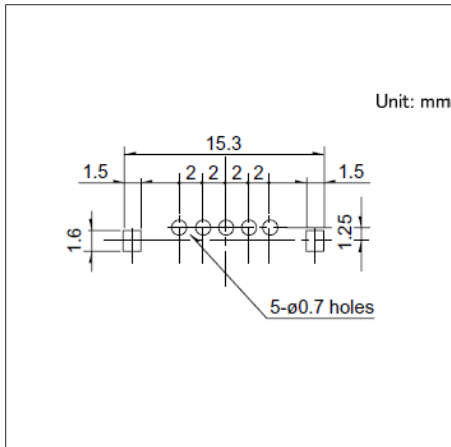

■ Circuit Diagram

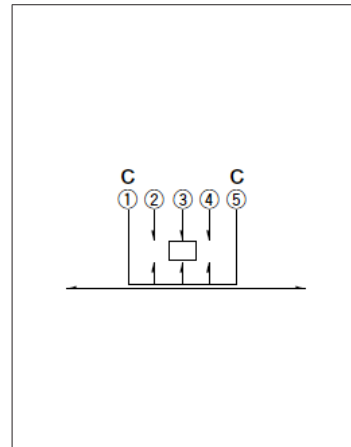

Viewed from direction A in the dimensions.

Drawing No.12

■ Dimensions

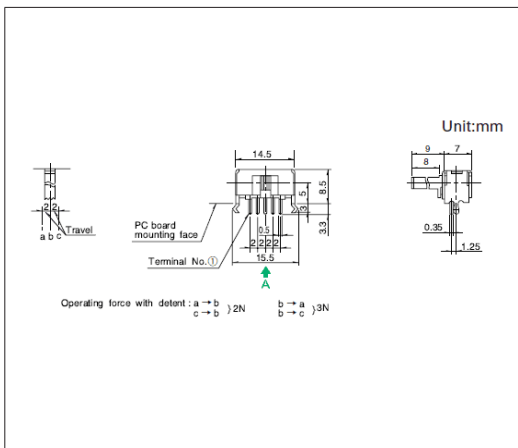

■ Mounting Hole Dimensions

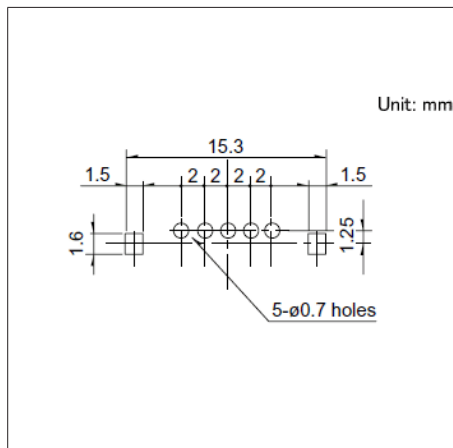

■ Circuit Diagram

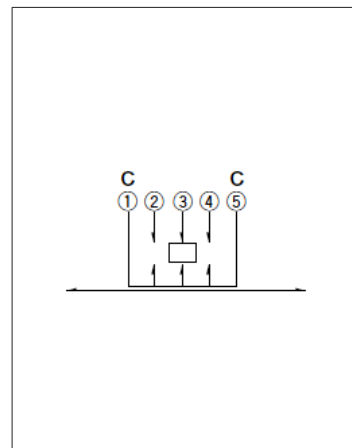

Viewed from direction A in the dimensions.

Drawing No.13

■ Dimensions

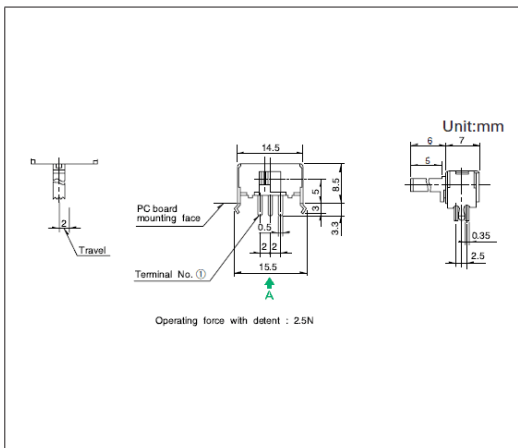

■ Mounting Hole Dimensions

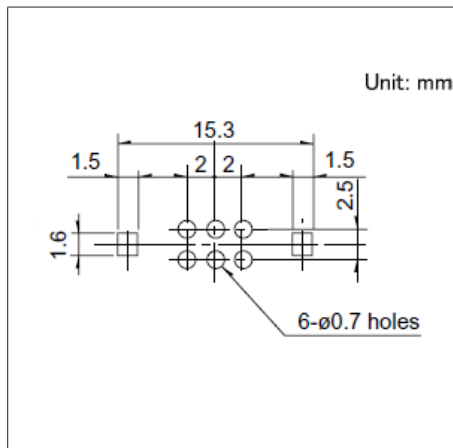

■ Circuit Diagram

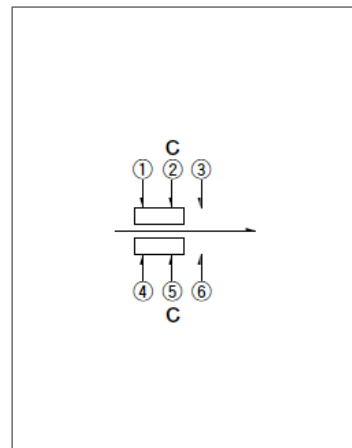

Viewed from direction A in the dimensions.

Drawing No.14

■ Dimensions

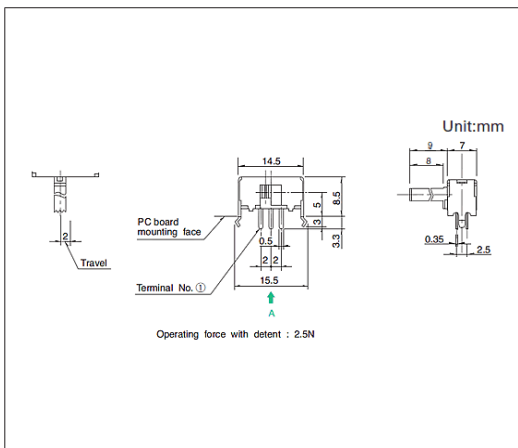

■ Mounting Hole Dimensions

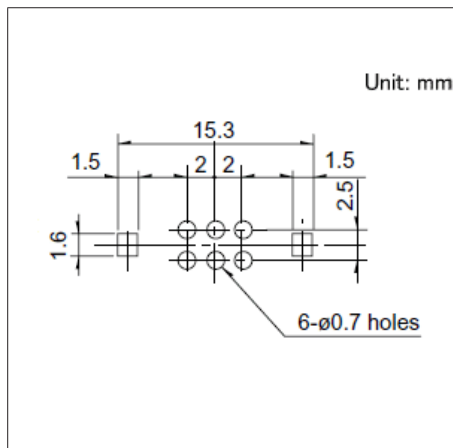

■ Circuit Diagram

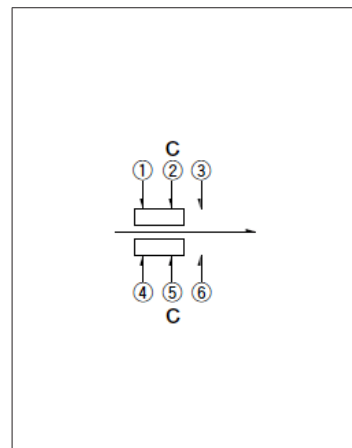

Viewed from direction A in the dimensions.

8.5 (H) mm, 2.0mm-travel  
SSSF Series

Drawing No.15

■ Dimensions

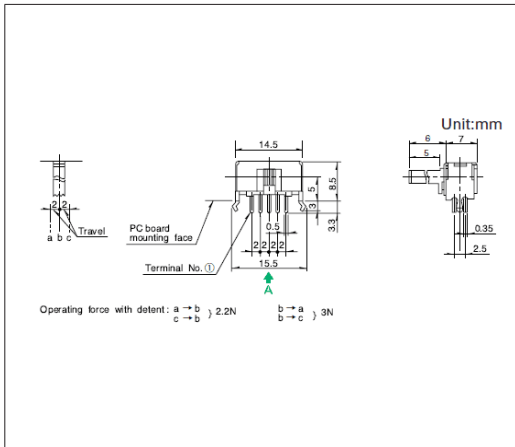

■ Mounting Hole Dimensions

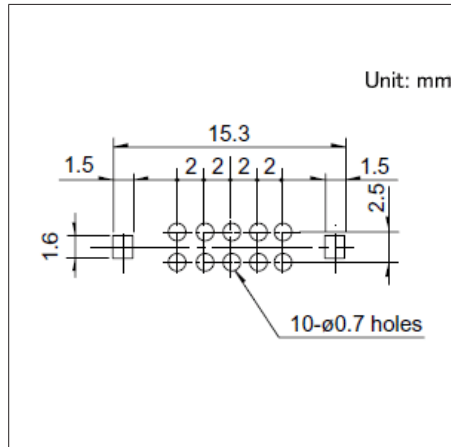

■ Circuit Diagram

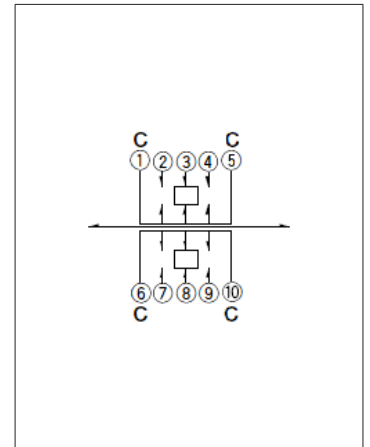

Viewed from direction A in the dimensions.

Drawing No.16

■ Dimensions

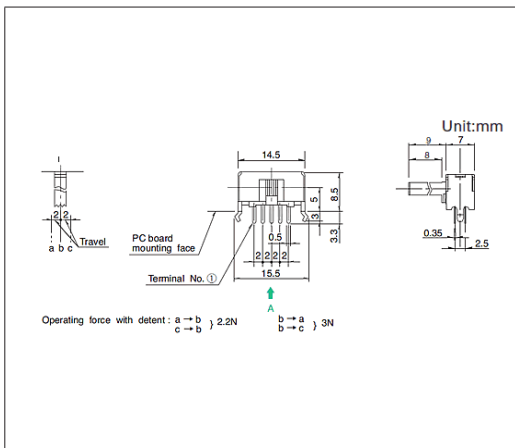

■ Mounting Hole Dimensions

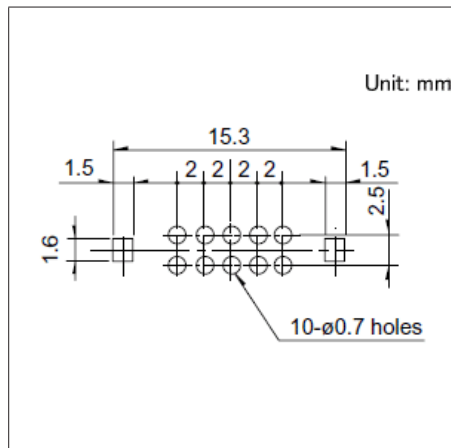

■ Circuit Diagram

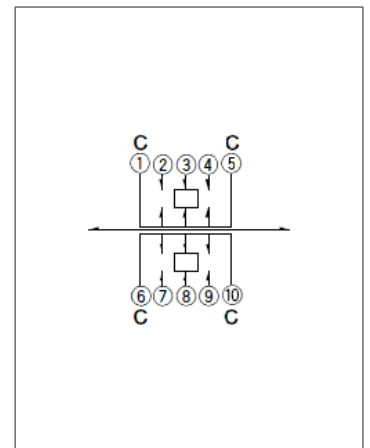

Viewed from direction A in the dimensions.

Drawing No.17

■ Dimensions

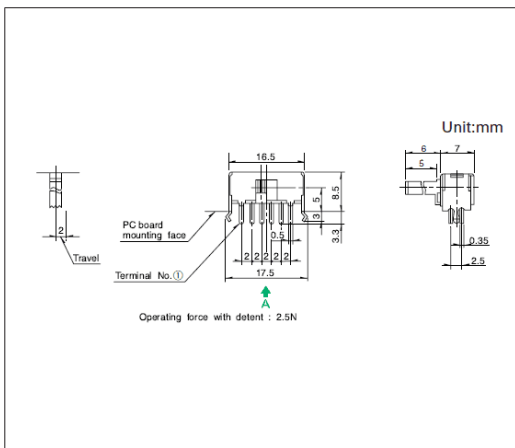

■ Mounting Hole Dimensions

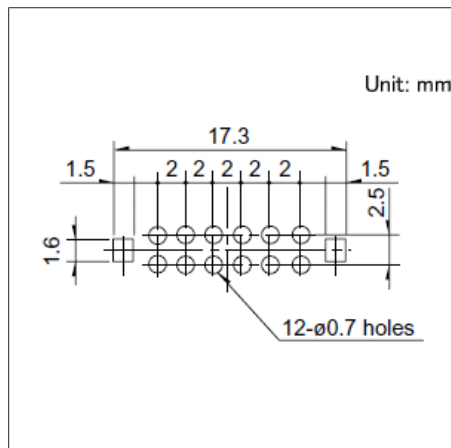

■ Circuit Diagram

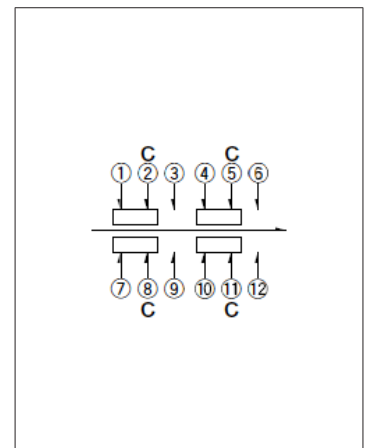

Viewed from direction A in the dimensions.

**Drawing No.18**

■ Dimensions

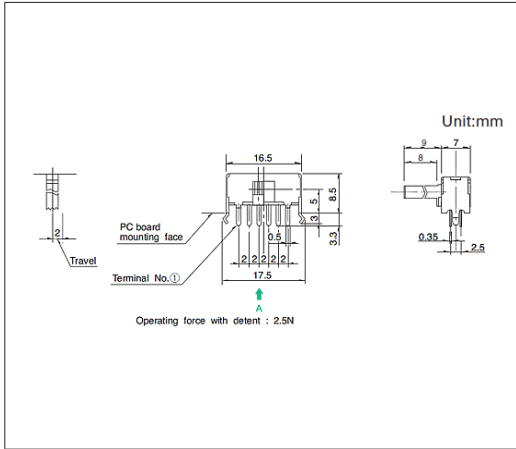

■ Mounting Hole Dimensions

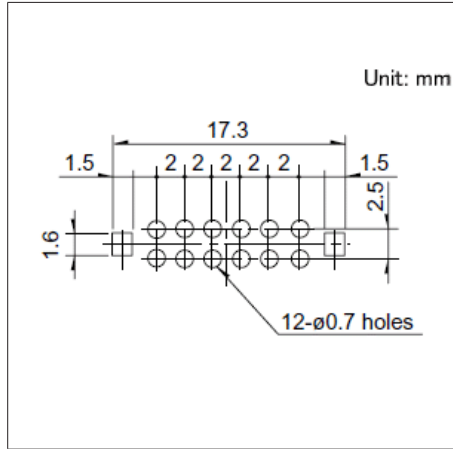

■ Circuit Diagram

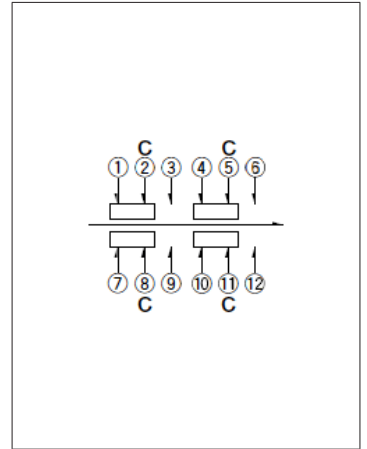

Viewed from direction A in the dimensions.

8.5 (H) mm, 3.0mm-travel

**SSSU Series**

Large general-purpose type with a wide variety of knob options.

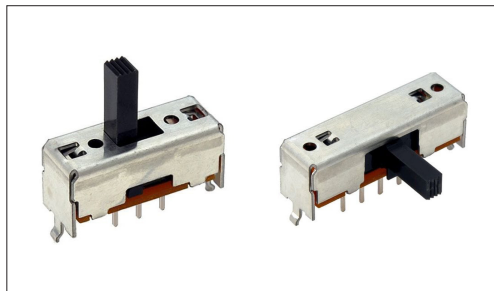

- Rating (max.)/(min.) (Resistive load): 0.1 A 30V DC/50 $\mu$ A 3V DC
- Contact resistance (Initial performance/After lifetime):  
25m $\Omega$  max./65m $\Omega$  max.
- Operating life without load: 10,000 cycles 45m $\Omega$  max.
- Operating life with load (at max. rated load): 10,000 cycles 65m $\Omega$  max.

Applications: Audio\_TV: Audio

## ■ Product List

Products No.	Actuator directions	Travel (mm)	Poles	Positions	Operating force	Changeover timing	Soldering	Dimensions (WxDxH) (mm)	Automotive	Drawing No.
SSSU011700	Vertical	3.0	1	2	Refer to the dimensions.	Non shorting	Manual, Dip	18.5×7.0×8.5	—	1
SSSU012200	Vertical	3.0	1	2	Refer to the dimensions.	Non shorting	Manual, Dip	18.5×7.0×8.5	—	2
SSSU014800	Vertical	3.0	1	3	Refer to the dimensions.	Non shorting	Manual, Dip	24.5×7.0×8.5	—	3
SSSU015100	Vertical	3.0	1	3	Refer to the dimensions.	Non shorting	Manual, Dip	24.5×7.0×8.5	—	4
SSSU022400	Vertical	3.0	2	2	Refer to the dimensions.	Non shorting	Manual, Dip	18.5×7.0×8.5	—	5
SSSU022800	Vertical	3.0	2	2	Refer to the dimensions.	Non shorting	Manual, Dip	18.5×7.0×8.5	—	6
SSSU025800	Vertical	3.0	2	3	Refer to the dimensions.	Non shorting	Manual, Dip	24.5×7.0×8.5	—	7
SSSU026300	Vertical	3.0	2	3	Refer to the dimensions.	Non shorting	Manual, Dip	24.5×7.0×8.5	—	8
SSSU041700	Vertical	3.0	4	2	Refer to the dimensions.	Non shorting	Manual, Dip	21.5×7.0×8.5	—	9
SSSU042100	Vertical	3.0	4	2	Refer to the dimensions.	Non shorting	Manual, Dip	21.5×7.0×8.5	—	10
SSSU111400	Horizontal	3.0	1	2	Refer to the dimensions.	Non shorting	Manual, Dip	18.5×7.0×8.5	—	11
SSSU113200	Horizontal	3.0	1	3	Refer to the dimensions.	Non shorting	Manual, Dip	24.5×7.0×8.5	—	12
SSSU121700	Horizontal	3.0	2	2	Refer to the dimensions.	Non shorting	Manual, Dip	18.5×7.0×8.5	—	13
SSSU122200	Horizontal	3.0	2	2	Refer to the dimensions.	Non shorting	Manual, Dip	18.5×7.0×8.5	—	14
SSSU124900	Horizontal	3.0	2	3	Refer to the dimensions.	Non shorting	Manual, Dip	24.5×7.0×8.5	—	15

## ⚠ Note

1. This catalog shows only outline specifications. When using the products, please obtain formal specifications for supply.
2. Please place purchase orders per minimum order unit (integer).

8.5 (H) mm, 3.0mm-travel  
**SSSU Series**

■ Packing Specifications

Bulk

Products No.	Number of packages (pcs.)		Export package measurements (mm)
	1 case / Japan	1 case / export packing	
SSSU011700 SSSU012200 SSSU022400 SSSU022800 SSSU124900	400	2,000	400 x 270 x 290
SSSU014800 SSSU015100 SSSU025800 SSSU026300 SSSU041700 SSSU042100 SSSU113200	500	2,500	400 x 270 x 290
SSSU111400 SSSU121700 SSSU122200	700	3,500	400 x 270 x 290

**Drawing No.1**

■ Dimensions

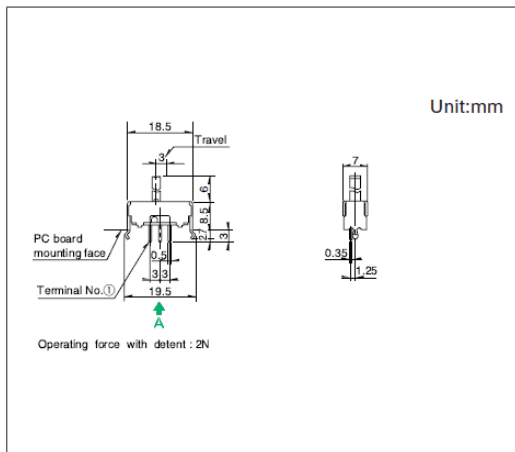

■ Mounting Hole Dimensions

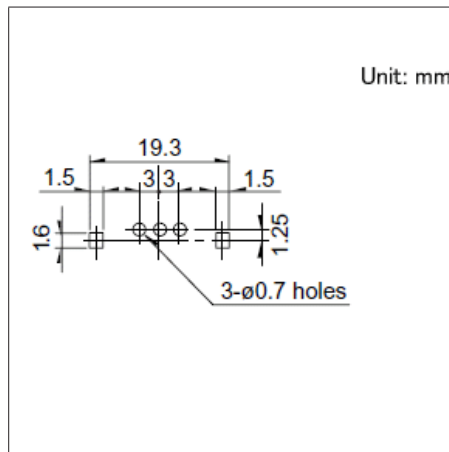

■ Circuit Diagram

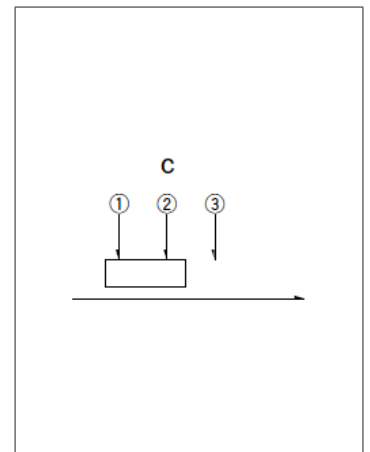

Viewed from direction A in the dimensions.

**Drawing No.2**

■ Dimensions

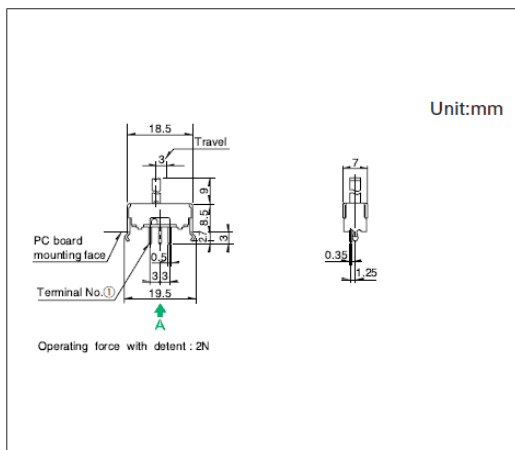

■ Mounting Hole Dimensions

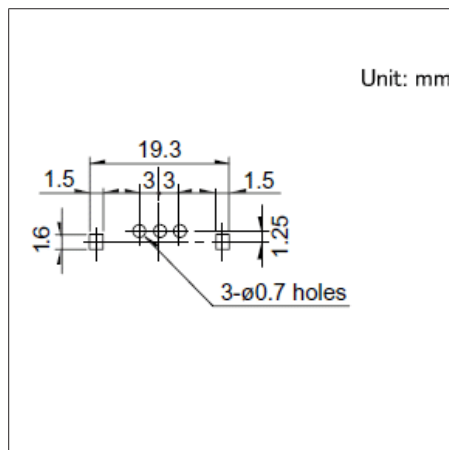

■ Circuit Diagram

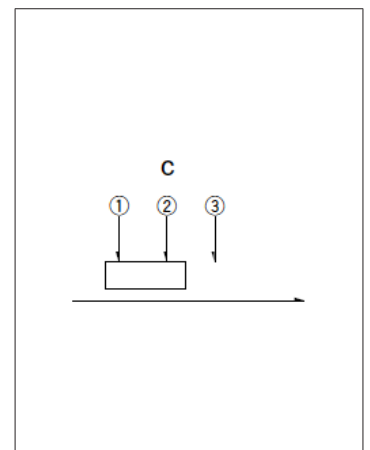

Viewed from direction A in the dimensions.

8.5 (H) mm, 3.0mm-travel  
SSSU Series

Drawing No.3

■ Dimensions

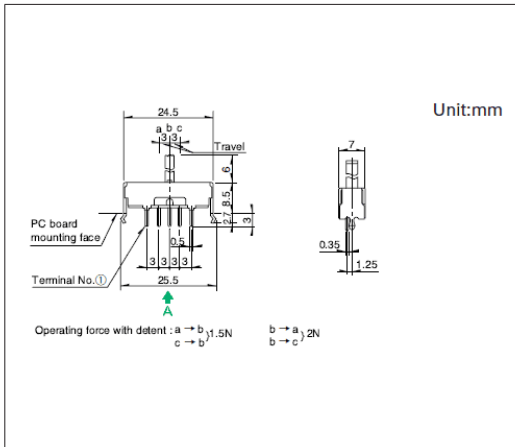

■ Mounting Hole Dimensions

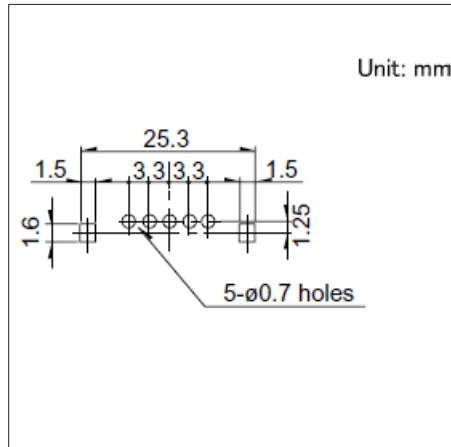

■ Circuit Diagram

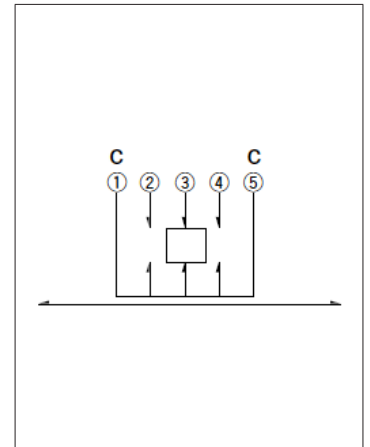

Viewed from direction A in the dimensions.

Drawing No.4

■ Dimensions

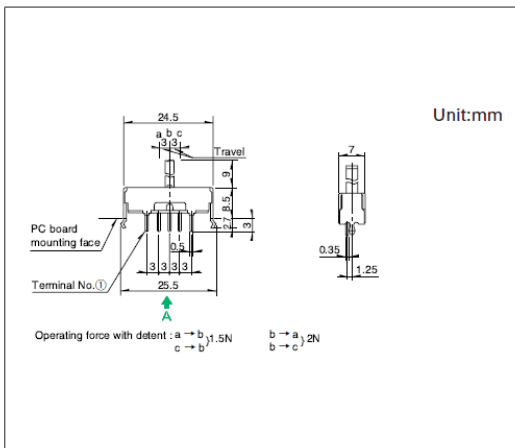

■ Mounting Hole Dimensions

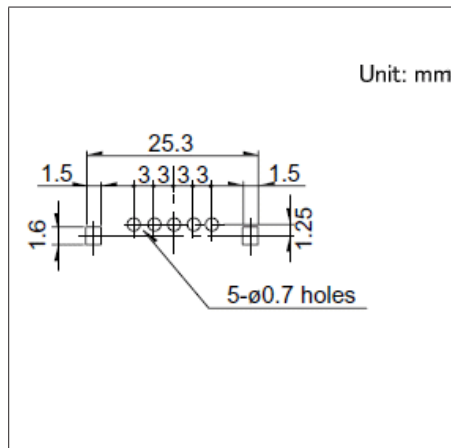

■ Circuit Diagram

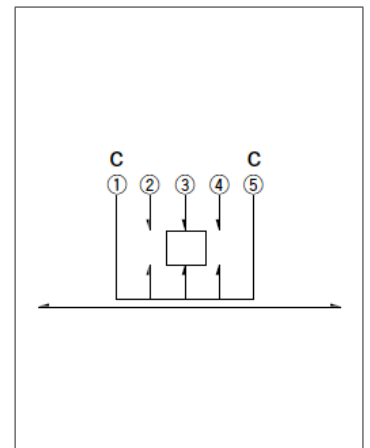

Viewed from direction A in the dimensions.

Drawing No.5

■ Dimensions

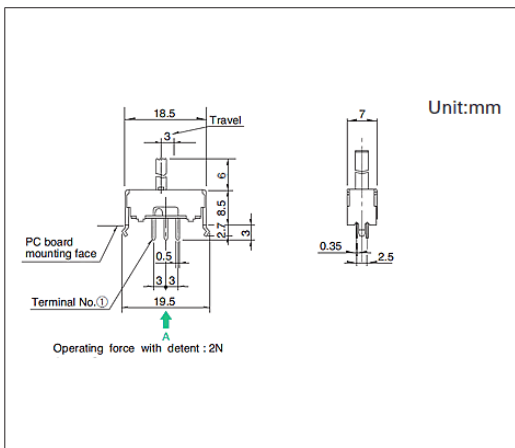

■ Mounting Hole Dimensions

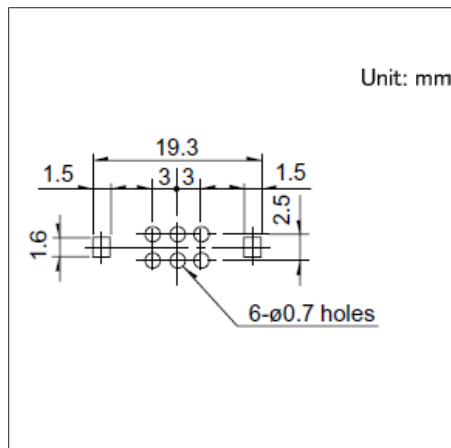

■ Circuit Diagram

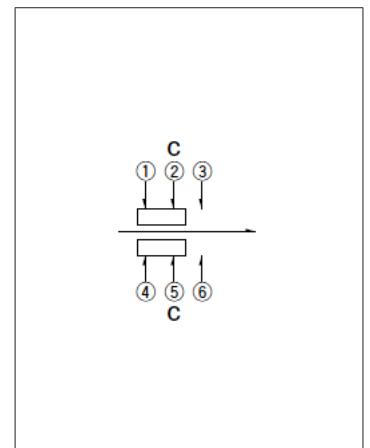

Viewed from direction A in the dimensions.

8.5 (H) mm, 3.0mm-travel  
SSSU Series

Drawing No.6

■ Dimensions

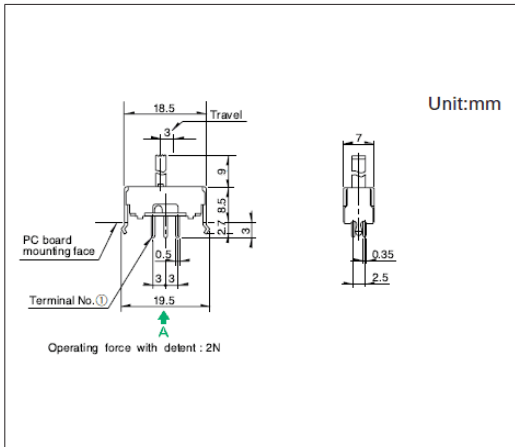

■ Mounting Hole Dimensions

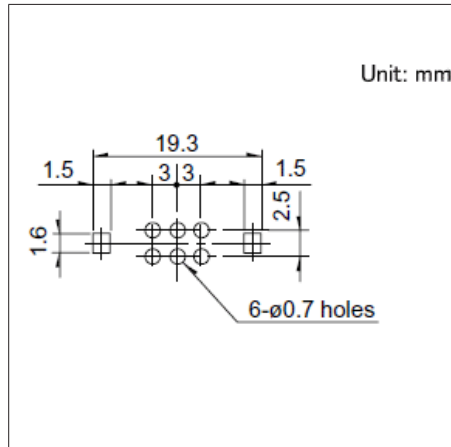

■ Circuit Diagram

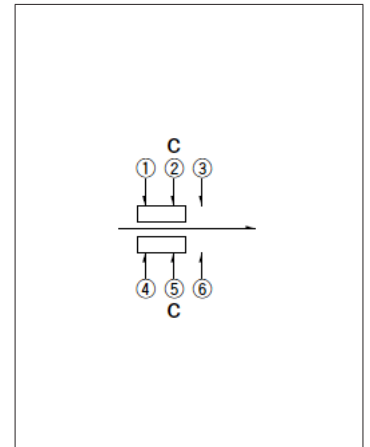

Viewed from direction A in the dimensions.

Drawing No.7

■ Dimensions

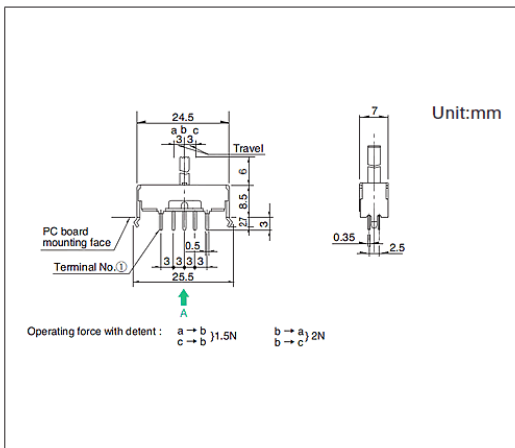

■ Mounting Hole Dimensions

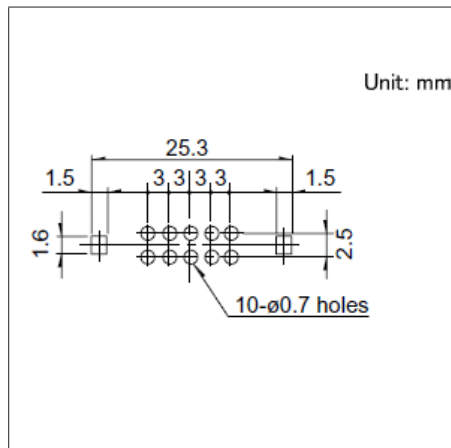

■ Circuit Diagram

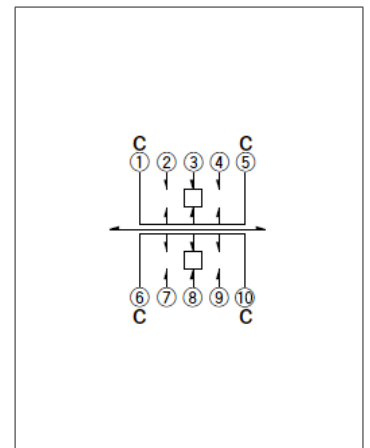

Viewed from direction A in the dimensions.

Drawing No.8

■ Dimensions

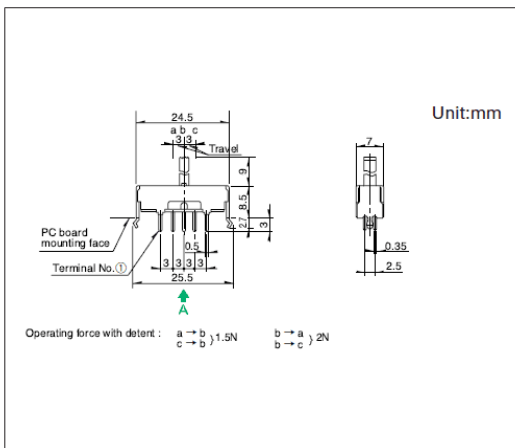

■ Mounting Hole Dimensions

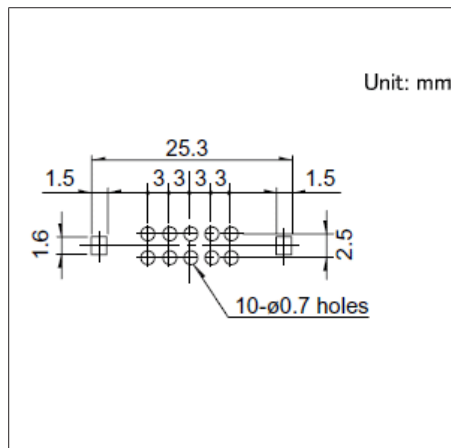

■ Circuit Diagram

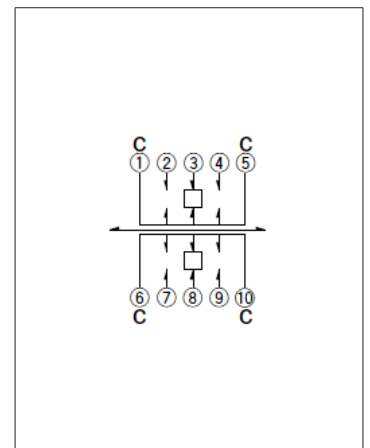

Viewed from direction A in the dimensions.

8.5 (H) mm, 3.0mm-travel  
SSSU Series

Drawing No.9

■ Dimensions

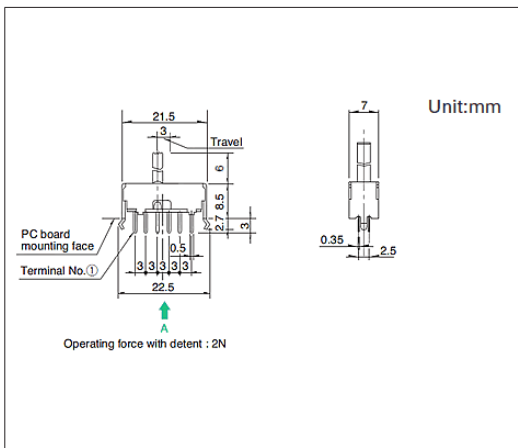

■ Mounting Hole Dimensions

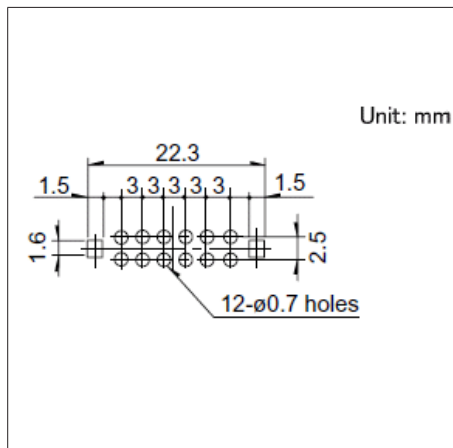

■ Circuit Diagram

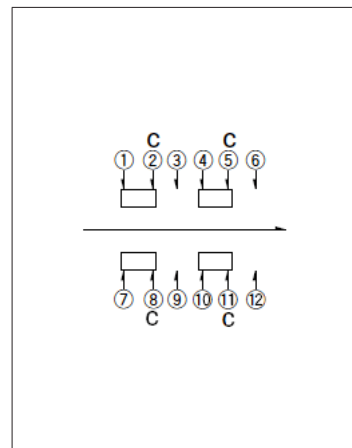

Viewed from direction A in the dimensions.

Drawing No.10

■ Dimensions

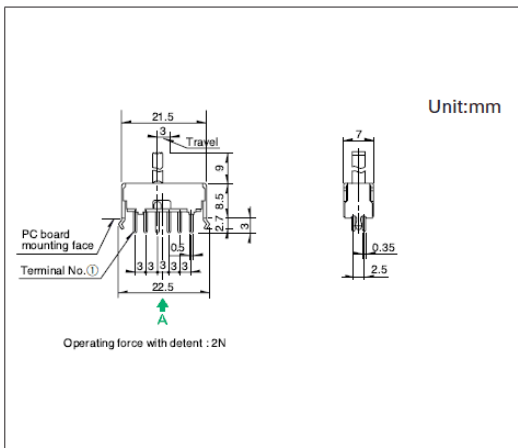

■ Mounting Hole Dimensions

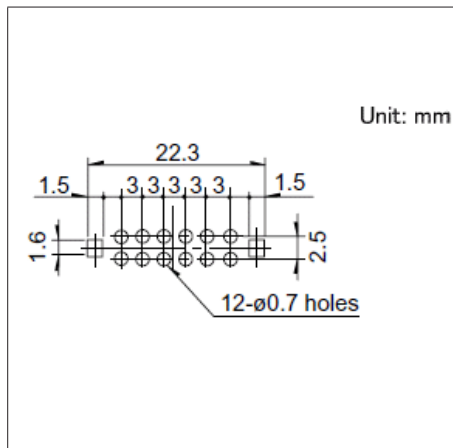

■ Circuit Diagram

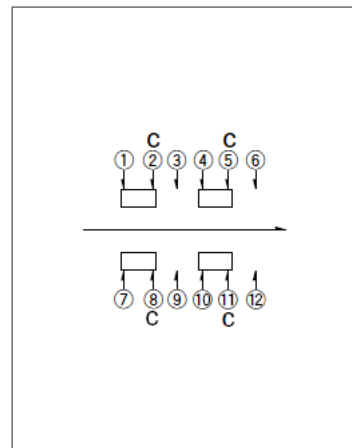

Viewed from direction A in the dimensions.

Drawing No.11

■ Dimensions

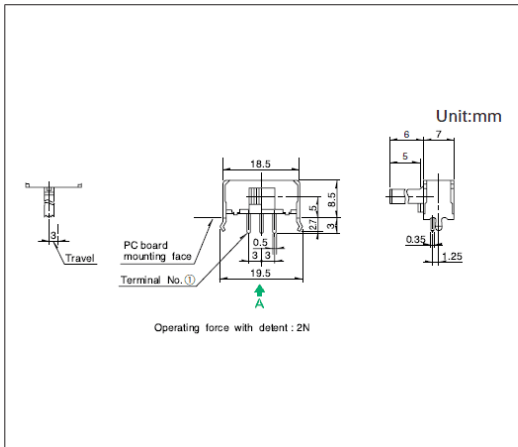

■ Mounting Hole Dimensions

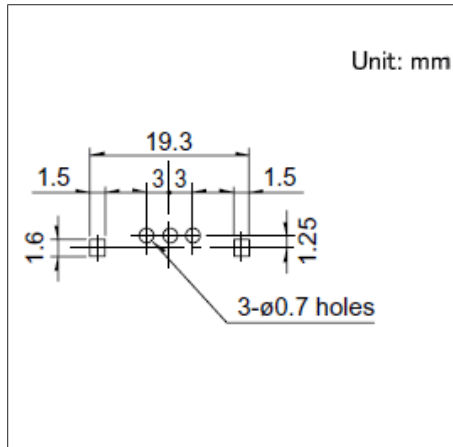

■ Circuit Diagram

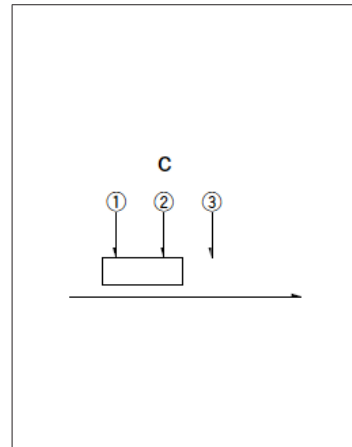

Viewed from direction A in the dimensions.

Drawing No.12

■ Dimensions

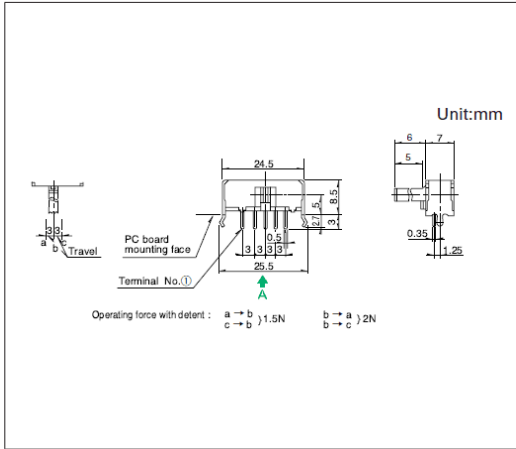

■ Mounting Hole Dimensions

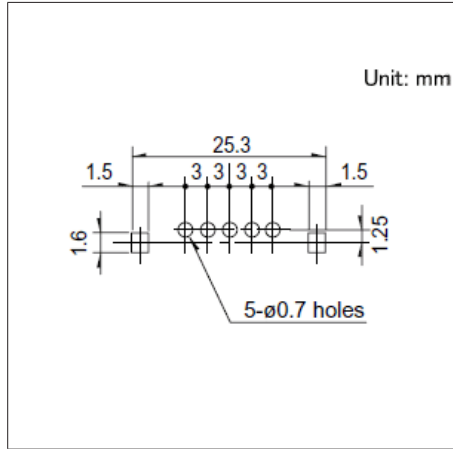

■ Circuit Diagram

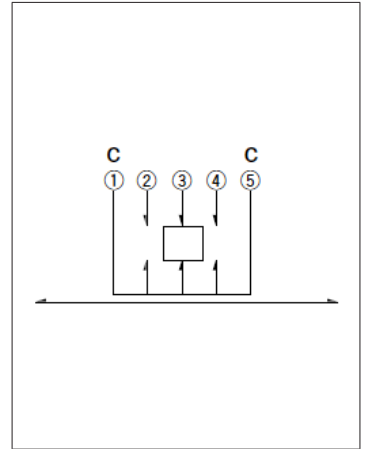

Viewed from direction A in the dimensions.

Drawing No.13

■ Dimensions

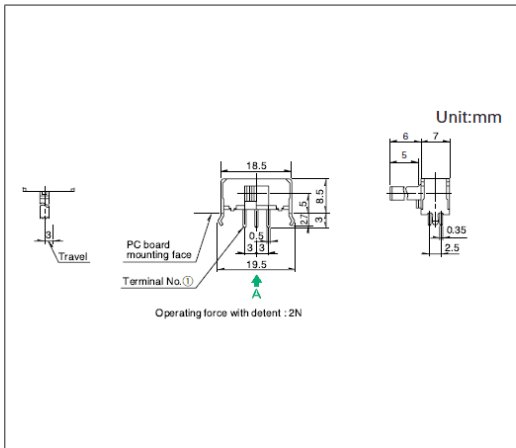

■ Mounting Hole Dimensions

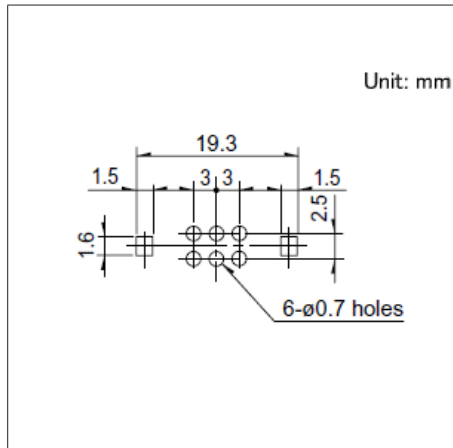

■ Circuit Diagram

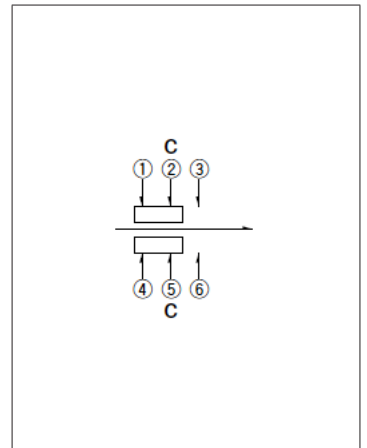

Viewed from direction A in the dimensions.

Drawing No.14

■ Dimensions

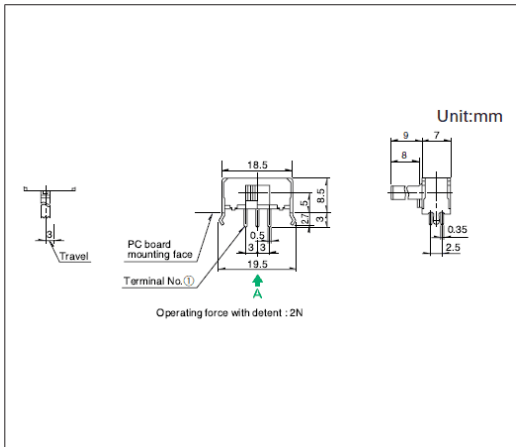

■ Mounting Hole Dimensions

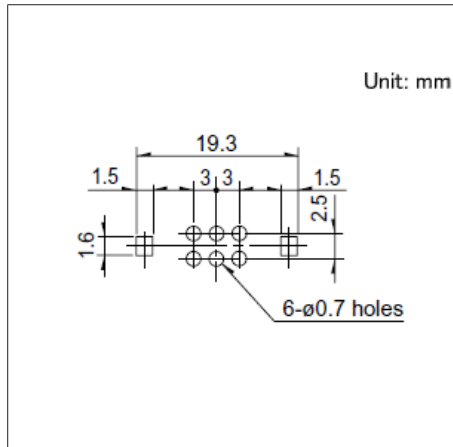

■ Circuit Diagram

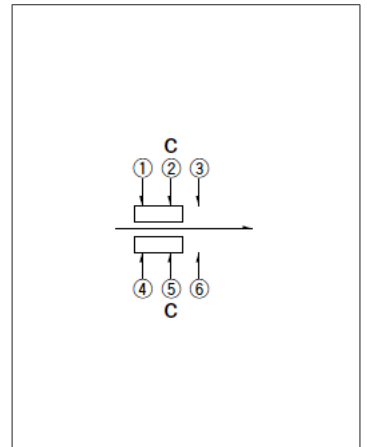

Viewed from direction A in the dimensions.

**Drawing No.15**

■ Dimensions

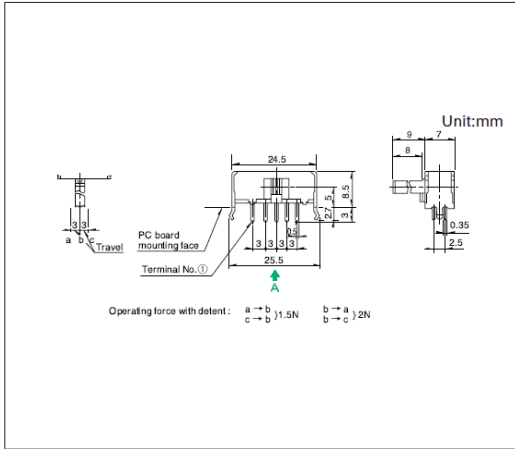

■ Mounting Hole Dimensions

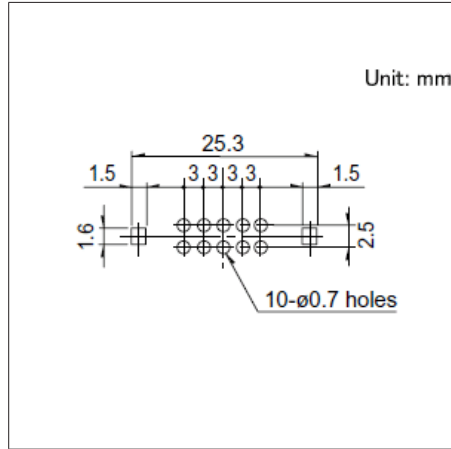

■ Circuit Diagram

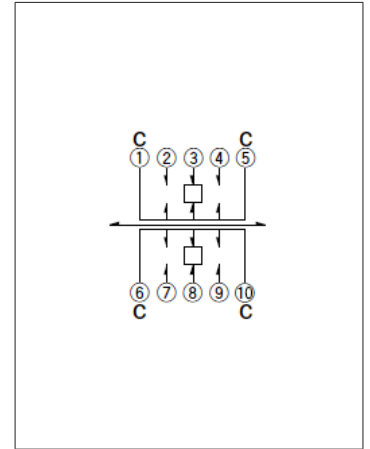

Viewed from direction A in the dimensions.

## Slide Switches / Soldering Conditions

### ■ Example of Reflow Soldering Condition

1. Heating method: Double heating method with infrared heater.
2. Temperature measurement: Thermocouple  $\phi 0.1$  to  $0.2$  CA (K) or CC (T) at soldering portion (copper foil surface).  
A heat resisting tape should be used for fixed measurement.
3. Temperature profile

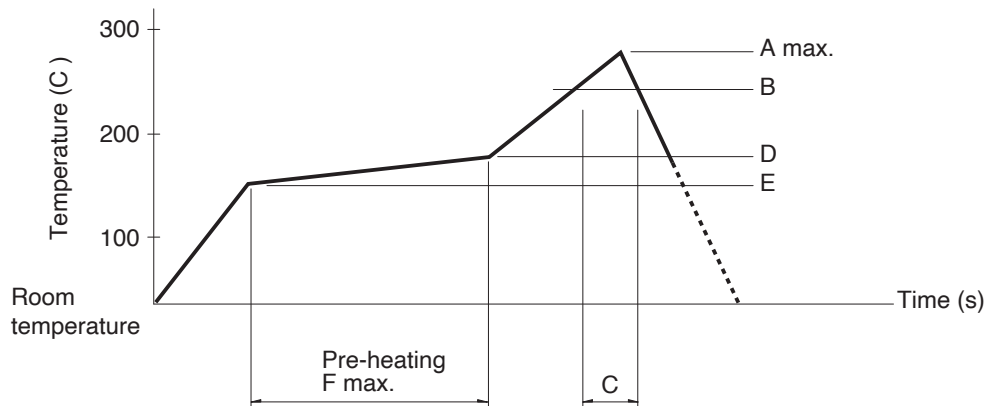

Series (Reflow type)		A (°C) 3s max.	B (°C)	C (s)	D (°C)	E (°C)	F (s)
SSSS2	Vertical 1-pole, 3-position	260	230	40	180	150	120
	Horizontal 1-pole, 2-position 1-pole, 3-position 2-pole, 3-position						
	Vertical 1-pole, 2-position	250					
SSAG, SSAJ, SSSS8, SSS7		260					

### ⚠ Note

1. The condition mentioned above is the temperature on the mounting surface of a PC board. There are cases where the PC board's temperature greatly differs from that of the switch, depending on the PC board's material, size, thickness, etc. The above-stated conditions shall also apply to switch surface temperatures.
2. Soldering conditions differ depending on reflow soldering machines. Prior verification of soldering condition is highly recommended.

### ■ Reference for Hand Soldering

Series	Soldering temperature	Soldering time
SSSF, SSSU	350±10°C	3+1/0s
SSSS2	350±10°C	4s max.
SSSS9	350±10°C	3s max.
SSAG, SSAJ	350±5°C	3s max.
SSSS8	330±5°C	3s max.
SSSS7	320±5°C	3s max.

### ■ Reference for Dip Soldering

(For PC board terminal types)

Series	Items		Dip soldering	
	Preheating temperature	Preheating time	Soldering temperature	Duration of immersion
SSSS2	100°C max.	60s max.	260±5°C	3±1s
SSSS9	120°C max.	60s max.	260±5°C	5+0/-1s (2 times)
SSSF, SSSU	100°C max.	60s max.	260±5°C	10±1s/5±1s







## Slide Switches / Cautions

1. Applying load to terminals during soldering under certain conditions may cause deformation and electrical property degradation.
2. Avoid use of water-soluble soldering flux, since it may corrode the switches.
3. Check and conform to soldering requirements under actual mass production conditions.
4. When soldering twice, wait until the first soldered portion cools to normal temperature. Continuous heating will deform the external portions, loosen or dislodge terminals, or may deteriorate their electrical characteristics.
5. Flux from around and above the PC board should not adhere to the switches.
6. After mounting the switches, if you intend to put the board into an oven in order to harden adhesive for other parts, please consult with us.
7. If you use a through-hole PC board or a PC board thinner or thicker than the recommendation, there may be greater heat stress. Verify the soldering conditions thoroughly before use.
8. Solder the switches with detent at the detent position. Soldering switches fixed at the center of the detent may deform the detent mechanisms.
9. No cleaning.
10. Protect small and thin switches from external forces in the set mounting process.
11. Tighten the mounting screws by applying the specified torque. Tightening with larger torque than the specified one will result in malfunction or breakage of screws.
12. Insert these switches to the specified mounting surface and mount them horizontally. If not mounted horizontally, these switches will malfunction.
13. The products are designed and manufactured for direct current resistance. Contact us for use of other resistances such as inductive (L) or capacitive (C).
14. The switch will break if you apply a greater stress than that specified. Take great care not to let the switch be subject to greater stress than specified.
15. Use of the switches in a dusty environment may lead to dusts entering through the openings and cause imperfect contact or malfunction. Take this into account for set design.
16. Corrosive gas if generated by peripheral parts of a set, malfunction such as imperfect contact may occur. Thorough investigation shall be required beforehand.
17. Storage  
Store the products as delivered at normal temperature and humidity, out of direct sunlight and away from corrosive gases. Use them as soon as possible and no later than six months after delivery.  
Once the seal is broken, use them as soon as possible.

## Switches

## Push Switches





## List of Varieties

Series		SPPJ3	SPPJ2	SPUJ	SPUN	SPEJ	SPPH4	SPPH1	
Photo									
Dimensions (mm)		12.0×5.0×8.3 12.0×6.6×8.3	12.0×7.2×9.6 14.0×17.7×9.6	15.2×7.5×8.8	24.0×10.0×13.0	7.0×7.0×5.95	8.5×6.5×8.5	10.0×10.0×8.5	
Travel (mm)		2.5		2.0	2.5	—	2.2	1.5	
Total travel (mm)		3.5		3.0	3.5	1.7	3.0	2.5	
Poles		1 2	2	2 4		2			
Operating force		2.3 ±1N 3.3 ±1N	3 ±1.5N	1.5 ±1N 2.3 ±1N	2 ±1N 2.5 ±1N 3 ±1.5N 4 ±2N	3.5 ±0.7N	2 ±1N	2 (+1, -0.7)N 3 (+1, -0.7)N	
Operating temperature range		-40°C to +85°C		-10°C to +60°C		-40°C to +85°C	-10°C to +60°C		
Rating (max.)/(min.) (Resistive load)		0.2A 30V DC/50μA 3V DC		0.1A 30V DC/ 50μA 3V DC	0.1A 30V DC/ 50μA 3V DC 1A 25V DC/ -	0.2A 14V DC/ -	0.1A 30V DC/50μA 3V DC		
Electrical performance	Contact resistance (Initial performance/ After lifetime)	20mΩ max./40mΩ max.				150mΩ max./ 150mΩ max.	100mΩ max. (Initial performance)	20mΩ max./ 40mΩ max.	
	Insulation resistance	100MΩ min. 500V DC							
	Voltage proof	500V AC for 1 minute							
Mechanical performance	Terminal strength	5N for 1 minute				—	5N for 1 minute		
	Actuator strength	Operating direction	50N	30N	50N	49N	30N	50N	
		Pulling direction	—		50N	—	10N	—	
Durability	Operating life without load	10,000 cycles 40mΩ max.			10,000 cycles 40mΩ max. 30,000 cycles 40mΩ max.	10,000 cycles 150mΩ max.	10,000 cycles 100mΩ max.	10,000 cycles 40mΩ max.	
	Operating life with load (at max. rated load)	10,000 cycles 40mΩ max.			5,000 cycles 40mΩ max. 10,000 cycles 40mΩ max.	10,000 cycles 150mΩ max.	10,000 cycles 100mΩ max.	10,000 cycles 40mΩ max.	
Environmental performance	Cold	-40°C 96h	-20°C 96h			-40°C 500h	-20°C 96h		
	Dry heat	85°C 96h				85°C 500h	85°C 96h		
	Damp heat	40°C, 90 to 95%RH 96h				60°C, 90 to 95%RH 500h	40°C, 90 to 95%RH 96h		
Automotive		●	●	—	—	●	—	●	

 Note

● Indicates applicability to all products in the series, while ○ indicates applicability to some products in the series.

# Push Switches

Series		SPEF	SPED2	SPED3	SPED4
Photo					
Dimensions (mm)		9.4×9.0×6.9	16.8×14.0×9.5	18.0×14.0×7.4	18.0×14.0×7.27
Travel (mm)		1.5	—		
Total travel (mm)		2.7	4.5	3.8	
Poles		1	1 2	1	
Operating force		3 N 5 N	4.17 ±0.74N		
Operating temperature range		-40°C to +85°C		-40°C to +95°C	
Rating (max.)/(min.) (Resistive load)		1A 14.5V DC/ 50μA 3V DC	1A 14.5V DC/ -	2A 14.5V DC/ -	
Electrical performance	Contact resistance (Initial performance/ After lifetime)	100mΩ max./ 1Ω max.	100mΩ max./100mΩ max.		
	Insulation resistance	3MΩ min. 100V DC	3MΩ min. 500V DC		
	Voltage proof	100V AC for 1 minute			
Mechanical performance	Terminal strength	—			
	Actuator strength	Operating direction	90N	98N	90N
		Pulling direction	30N	—	
Durability	Operating life without load	—			
	Operating life with load (at max. rated load)	30,000 cycles 100mΩ max.			
Environmental performance	Cold	-40°C 96h			
	Dry heat	85°C 96h	85°C 96h 105°C 192h	105°C 192h	
	Damp heat	40°C, 90 to 95%RH 96h			
Automotive		●	●	●	●

### ⚠ Note

● Indicates applicability to all products in the series, while ○ indicates applicability to some products in the series.

## 2.5mm-travel Compact-sized Horizontal Type SPPJ3 Series

Compact type with a lever height of 4.7mm.

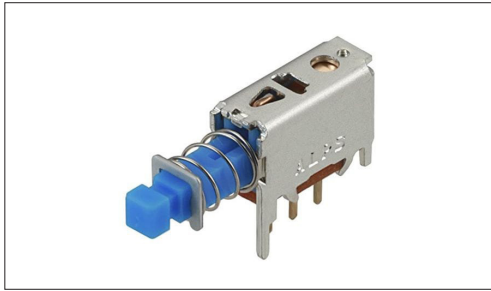

 Automotive

- Rating (max.)/(min.) (Resistive load): 0.2A 30V DC/50 $\mu$ A 3V DC
- Contact resistance (Initial performance/After lifetime):  
20m $\Omega$  max./40m $\Omega$  max.
- Operating life without load: 10,000 cycles 40m $\Omega$  max.
- Operating life with load (at max. rated load): 10,000 cycles 40m $\Omega$  max.

Applications: Healthcare: Healthcare equipment  
Automotive: Navigation/audio systems, HVAC

### Product List

Products No.	Travel (mm)	Total travel (mm)	Poles	Operating force	Changeover timing	Mounting method	Operation	Terminal type	Dimensions (W×D×H) (mm)	Automotive	Drawing No.
SPPJ310500	2.5	3.5	1	2.3±1N	Non shorting	PC board	Latching	For PC board	12.0×5.0×8.3	●	1
SPPJ311500	2.5	3.5	1	2.3±1N	Non shorting	PC board	Momentary	For PC board	12.0×5.0×8.3	●	
SPPJ320600	2.5	3.5	2	3.3±1N	Non shorting	PC board	Latching	For PC board	12.0×6.6×8.3	●	2
SPPJ322300	2.5	3.5	2	3.3±1N	Non shorting	PC board	Momentary	For PC board	12.0×6.6×8.3	●	

### Note

1. This catalog shows only outline specifications. When using the products, please obtain formal specifications for supply.
2. Please place purchase orders per minimum order unit (integer).
3. This products can be used in vehicles.  
Although these products are designed to perform over a wide operating temperature range, please ensure that you receive and read the formal delivery specifications before use.
4. The SPPJ3 series should be operated in the direction of the arrow 2 as shown in the following figure and used within an angle of 15° in reference to the center. If an excessive force is applied from the direction of the arrow 1 against the lever, it might fall as illustrated, resulting in malfunction.

### Packing Specifications

Bulk

Number of packages (pcs.)		Export package measurements (mm)
1 case / Japan	1 case / export packing	
900	4,500	400 x 270 x 290

2.5mm-travel Compact-sized Horizontal Type  
**SPPJ3 Series**

**Drawing No.1**

■ Dimensions

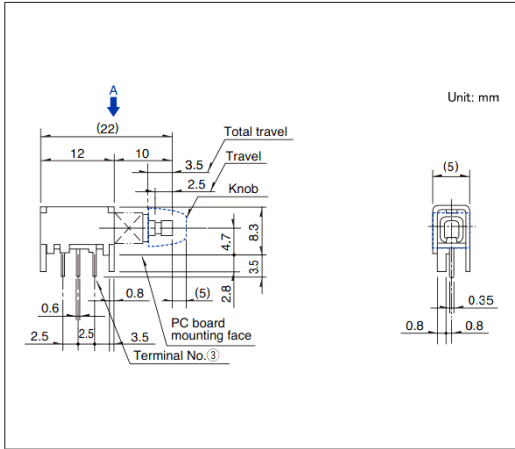

■ Mounting Hole Dimensions

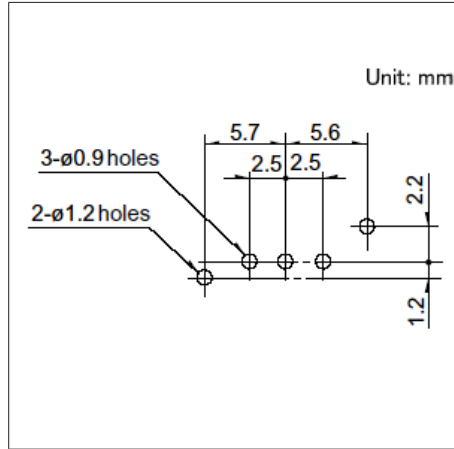

■ Circuit Diagram

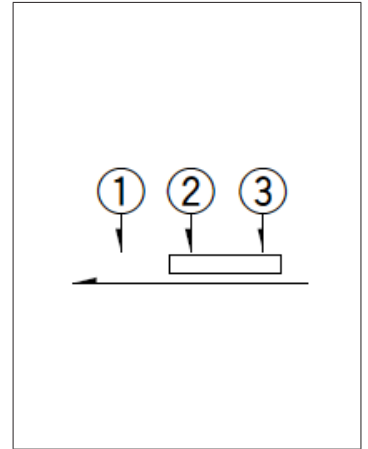

Viewed from direction A in the dimensions.

**Drawing No.2**

■ Dimensions

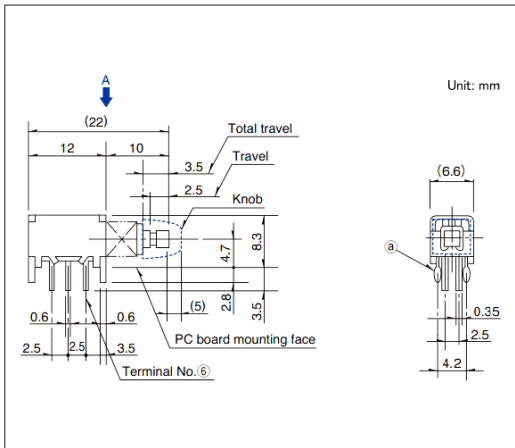

■ Mounting Hole Dimensions

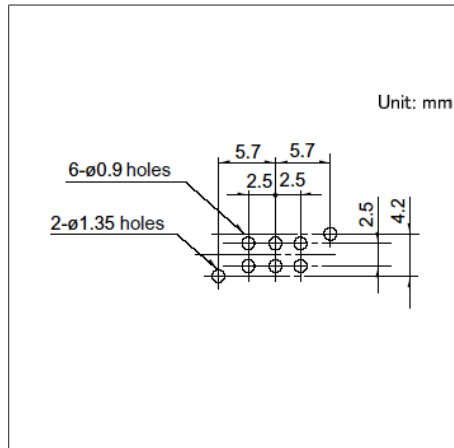

■ Circuit Diagram

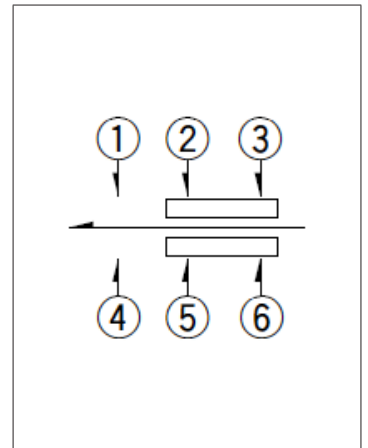

Viewed from direction A in the dimensions.

Switches Push Switches

2.5mm-travel Horizontal Type  
**SPPJ2 Series**

Lever height of 5.5mm, mountable directly on panels.

Automotive

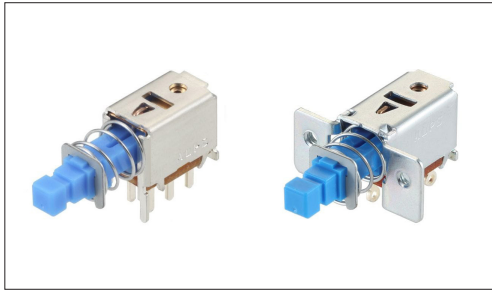

- Rating (max.)/(min.) (Resistive load): 0.2A 30V DC/50μA 3V DC
- Contact resistance (Initial performance/After lifetime):  
20mΩ max./40mΩ max.
- Operating life without load: 10,000 cycles 40mΩ max.
- Operating life with load (at max. rated load): 10,000 cycles 40mΩ max.

Applications: Automotive: Navigation/audio systems, HVAC

■ Product List

Products No.	Travel (mm)	Total travel (mm)	Poles	Operating force	Changeover timing	Mounting method	Operation	Terminal type	Dimensions (W×D×H) (mm)	Automotive	Drawing No.
SPPJ222200	2.5	3.5	2	3±1.5N	Non shorting	PC board	Latching	For PC board	12.0×7.2×9.6	●	1
SPPJ223200	2.5	3.5	2	3±1.5N	Non shorting	PC board	Momentary	For PC board	12.0×7.2×9.6	●	
SPPJ225800	2.5	3.5	2	3±1.5N	Non shorting	M2-screw	Latching	Lead	14.0×17.7×9.6	●	2
SPPJ226400	2.5	3.5	2	3±1.5N	Non shorting	M2-screw	Momentary	Lead	14.0×17.7×9.6	●	

Note

1. This catalog shows only outline specifications. When using the products, please obtain formal specifications for supply.
2. Please place purchase orders per minimum order unit (integer).
3. This products can be used in vehicles.  
Although these products are designed to perform over a wide operating temperature range, please ensure that you receive and read the formal delivery specifications before use.

■ Packing Specifications

Bulk

Products No.	Number of packages(pcs.)		Export package measurements (mm)
	1 case / Japan	1 case / export packing	
SPPJ222200 SPPJ223200	700	3,500	400 x 270 x 290
SPPJ225800 SPPJ226400	500	2,500	400 x 270 x 290

Drawing No.1

■ Dimensions

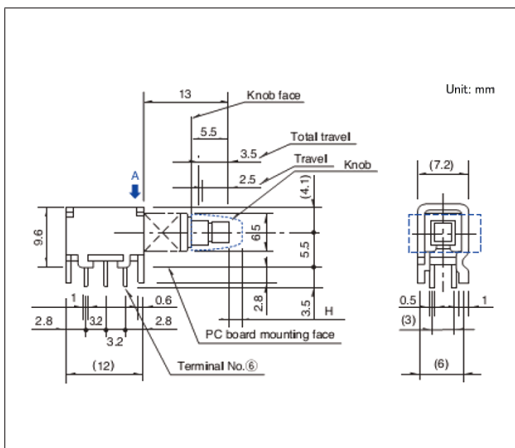

■ Mounting Hole Dimensions

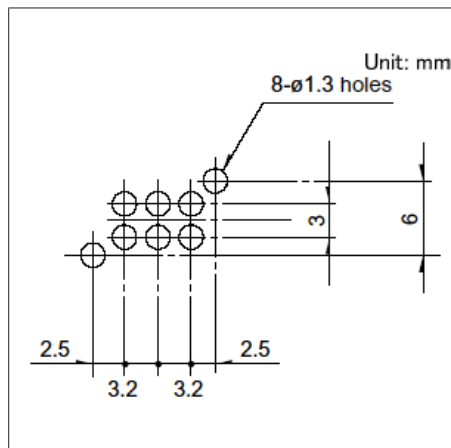

■ Circuit Diagram

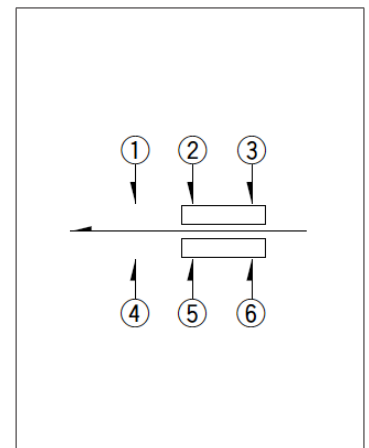

Viewed from direction A in the dimensions.



## 2.0mm-travel Horizontal Type SPUJ Series

Lever height of 5.0mm, supporting multi-circuit configurations.

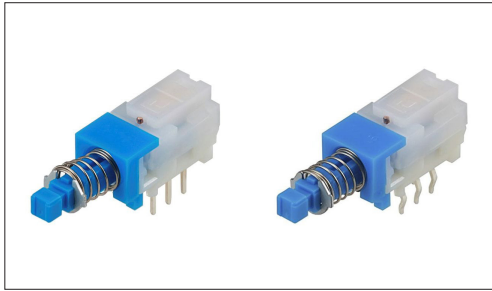

- Rating (max.)/(min.) (Resistive load): 0.1 A 30V DC/50 $\mu$ A 3V DC
- Contact resistance (Initial performance/After lifetime):  
20m $\Omega$  max./40m $\Omega$  max.
- Operating life without load: 10,000 cycles 40m $\Omega$  max.
- Operating life with load (at max. rated load): 10,000 cycles 40m $\Omega$  max.

Applications: Audio\_TV:Audio

### Product List

Products No.	Travel (mm)	Total travel (mm)	Poles	Operating force	Changeover timing	Mounting method	Operation	Terminal type	Dimensions (WxDxH) (mm)	Automotive	Drawing No.
SPUJ190900	2.0	3.0	2	1.5 $\pm$ 1N	Non shorting	PC board	Latching	Straight	15.2 $\times$ 7.5 $\times$ 8.8	—	1
SPUJ191000	2.0	3.0	2	1.5 $\pm$ 1N	Non shorting	PC board	Latching	Snap-in	15.2 $\times$ 7.5 $\times$ 8.8	—	2
SPUJ191500	2.0	3.0	2	1.5 $\pm$ 1N	Non shorting	PC board	Momentary	Straight	15.2 $\times$ 7.5 $\times$ 8.8	—	1
SPUJ191900	2.0	3.0	2	1.5 $\pm$ 1N	Non shorting	PC board	Momentary	Snap-in	15.2 $\times$ 7.5 $\times$ 8.8	—	2
SPUJ193700	2.0	3.0	4	2.3 $\pm$ 1N	Non shorting	PC board	Latching	Straight	15.2 $\times$ 7.5 $\times$ 8.8	—	3
SPUJ193900	2.0	3.0	4	2.3 $\pm$ 1N	Non shorting	PC board	Latching	Snap-in	15.2 $\times$ 7.5 $\times$ 8.8	—	4
SPUJ194500	2.0	3.0	4	2.3 $\pm$ 1N	Non shorting	PC board	Momentary	Straight	15.2 $\times$ 7.5 $\times$ 8.8	—	3

### Note

1. This catalog shows only outline specifications. When using the products, please obtain formal specifications for supply.
2. Please place purchase orders per minimum order unit (integer).

### Packing Specifications

Bulk

Products No.	Number of packages (pcs.)		Export package measurements (mm)
	1 case / Japan	1 case / export packing	
SPUJ190900 SPUJ191000 SPUJ191500 SPUJ191900	600	3,000	400 x 270 x 290
SPUJ193700 SPUJ193900 SPUJ194500	400	2,000	400 x 270 x 290

2.0mm-travel Horizontal Type  
SPUJ Series

Drawing No.1

■ Dimensions

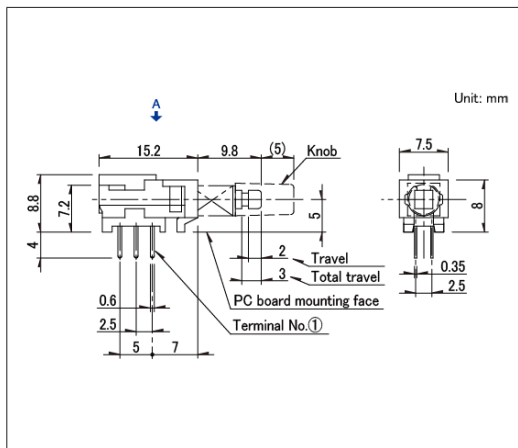

■ Mounting Hole Dimensions

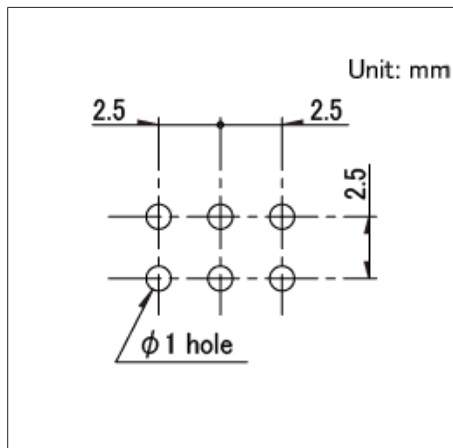

■ Circuit Diagram

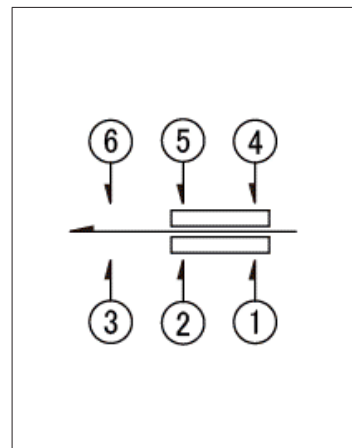

Viewed from direction A in the dimensions.

Drawing No.2

■ Dimensions

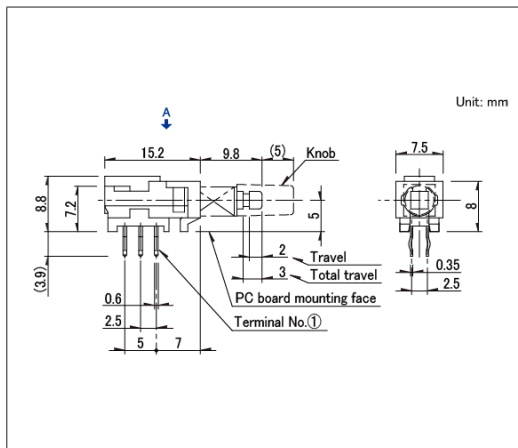

■ Mounting Hole Dimensions

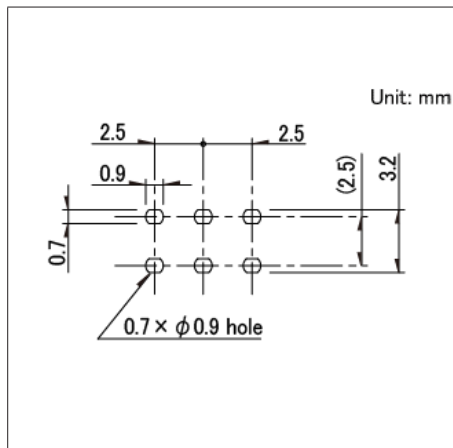

■ Circuit Diagram

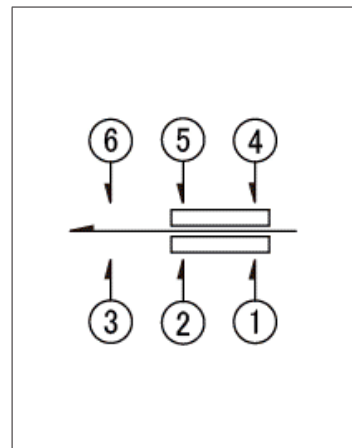

Viewed from direction A in the dimensions.

Drawing No.3

■ Dimensions

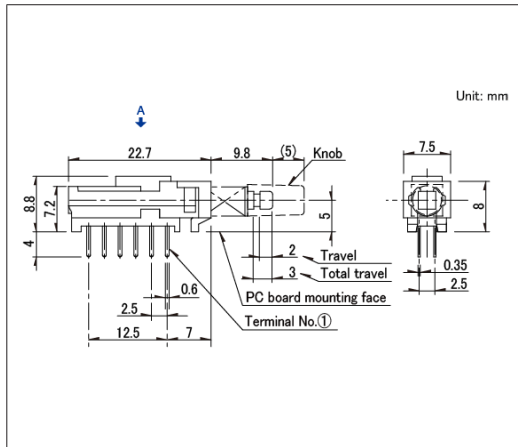

■ Mounting Hole Dimensions

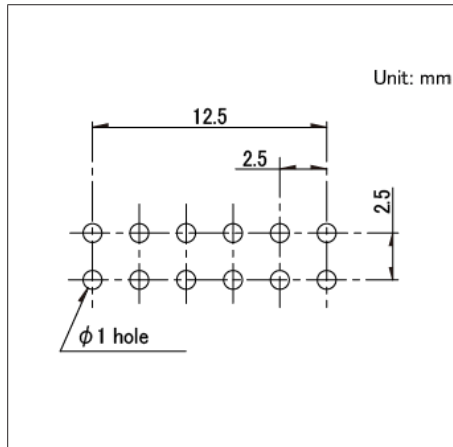

■ Circuit Diagram

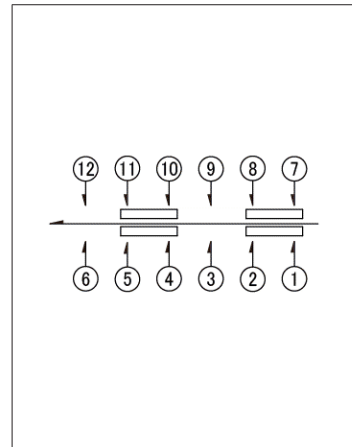

Viewed from direction A in the dimensions.

2.0mm-travel Horizontal Type  
**SPUJ Series**

**Drawing No.4**

■ Dimensions

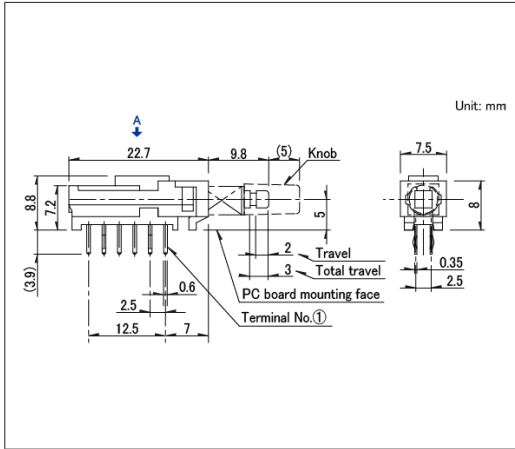

■ Mounting Hole Dimensions

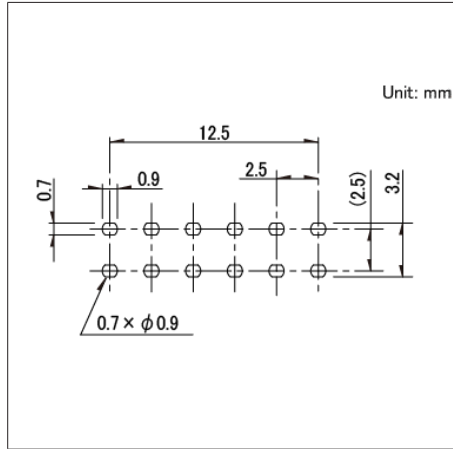

■ Circuit Diagram

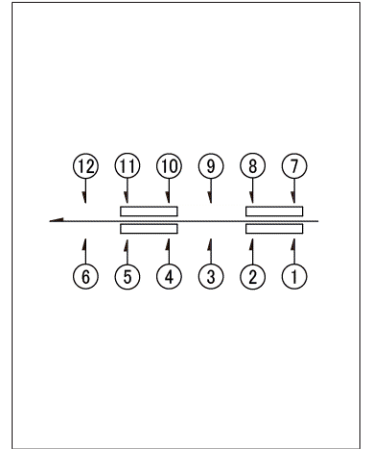

Viewed from direction A in the dimensions.

## 2.5mm-travel Large-sized Horizontal Type SPUN Series

Includes multi-circuit and medium-current options in the lineup.

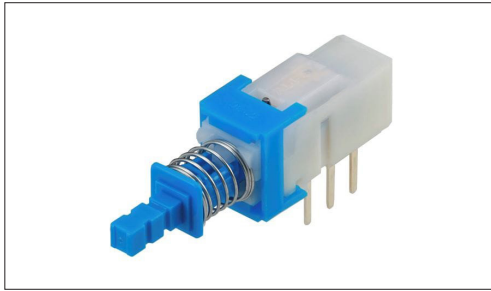

- Rating (max.)/(min.) (Resistive load): 0.1 A 30V DC/50 $\mu$ A 3V DC (Standard)  
1 A 25V DC/ - (Medium-current)
- Contact resistance (Initial performance/After lifetime):  
20m $\Omega$  max./40m $\Omega$  max.
- Operating life without load: 30,000 cycles 40m $\Omega$  max. (Standard)  
10,000 cycles 40m $\Omega$  max. (Medium-current)
- Operating life with load (at max. rated load):  
10,000 cycles 40m $\Omega$  max. (Standard)  
5,000 cycles 40m $\Omega$  max. (Medium-current)

Applications: Audio\_TV: Audio

### ■ Product List

Products No.	Travel (mm)	Total travel (mm)	Rating	Poles	Operating force	Changeover timing	Mounting method	Operation	Terminal type	Dimensions (W×D×H) (mm)	Automotive	Drawing No.
SPUN191400	2.5	3.5	Standard	2	2 $\pm$ 1N	Non shorting	PC board	Latching	Straight	24.0×10.0×13.0	—	1
SPUN191600	2.5	3.5	Standard	2	2 $\pm$ 1N	Non shorting	PC board	Latching	Snap-in	24.0×10.0×13.0	—	2
SPUN190900	2.5	3.5	Standard	2	2 $\pm$ 1N	Non shorting	PC board	Momentary	Straight	24.0×10.0×13.0	—	1
SPUN191000	2.5	3.5	Standard	2	2 $\pm$ 1N	Non shorting	PC board	Momentary	Snap-in	24.0×10.0×13.0	—	2
SPUN194700	2.5	3.5	Standard	4	2.5 $\pm$ 1N	Non shorting	PC board	Latching	Straight	24.0×10.0×13.0	—	3
SPUN194900	2.5	3.5	Standard	4	2.5 $\pm$ 1N	Non shorting	PC board	Latching	Snap-in	24.0×10.0×13.0	—	4
SPUN192600	2.5	3.5	Medium-current	2	3 $\pm$ 1.5N	Non shorting	PC board	Latching	Straight	24.0×10.0×13.0	—	5
SPUN192800	2.5	3.5	Medium-current	2	3 $\pm$ 1.5N	Non shorting	PC board	Latching	Snap-in	24.0×10.0×13.0	—	2
SPUN19C400	2.5	3.5	Medium-current	4	4 $\pm$ 2N	Non shorting	PC board	Latching	Snap-in	24.0×10.0×13.0	—	4

### ⚠ Note

1. This catalog shows only outline specifications. When using the products, please obtain formal specifications for supply.
2. Please place purchase orders per minimum order unit (integer).

### ■ Packing Specifications

Bulk

Products No.	Number of packages (pcs.)		Export package measurements (mm)
	1 case / Japan	1 case / export packing	
SPUN191400 SPUN191600 SPUN190900 SPUN191000 SPUN192600 SPUN192800	250	1,250	400 x 270 x 290
SPUN194700 SPUN194900 SPUN19C400	140	700	400 x 270 x 290

2.5mm-travel Large-sized Horizontal Type  
**SPUN Series**

**Drawing No.1**

■ Dimensions

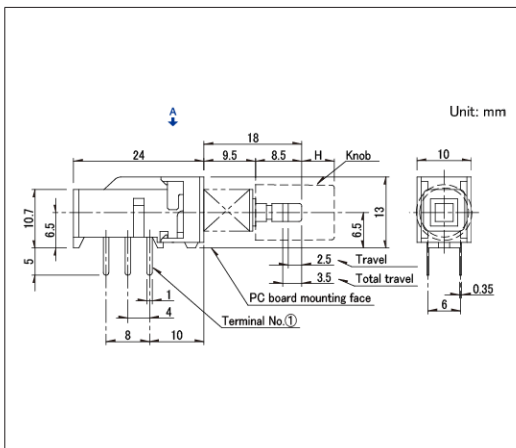

■ Mounting Hole Dimensions

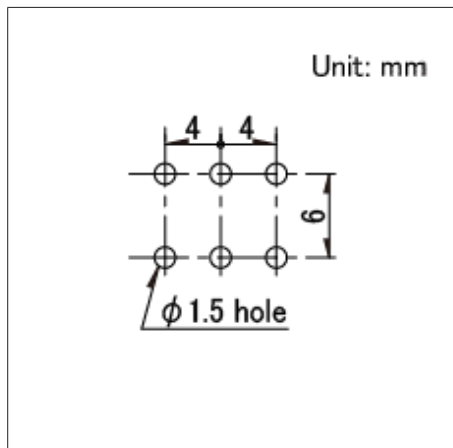

■ Circuit Diagram

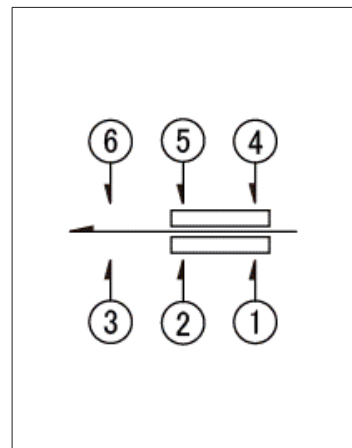

Viewed from direction A in the dimensions.

**Drawing No.2**

■ Dimensions

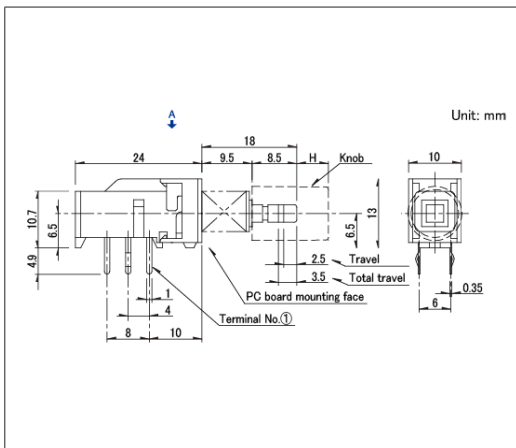

■ Mounting Hole Dimensions

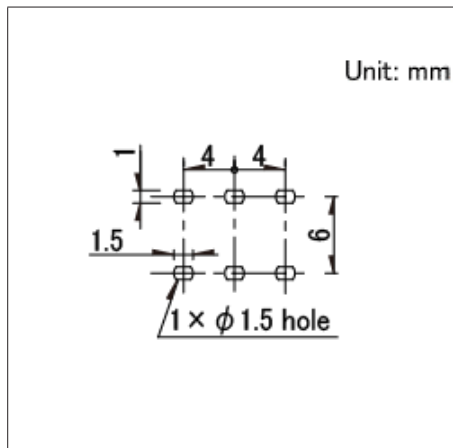

■ Circuit Diagram

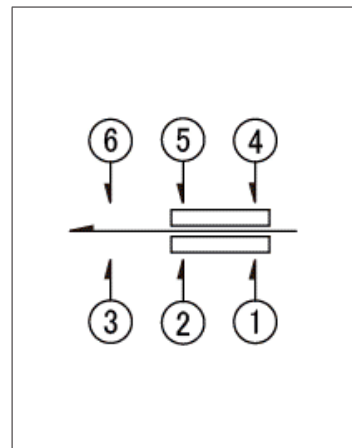

Viewed from direction A in the dimensions.

**Drawing No.3**

■ Dimensions

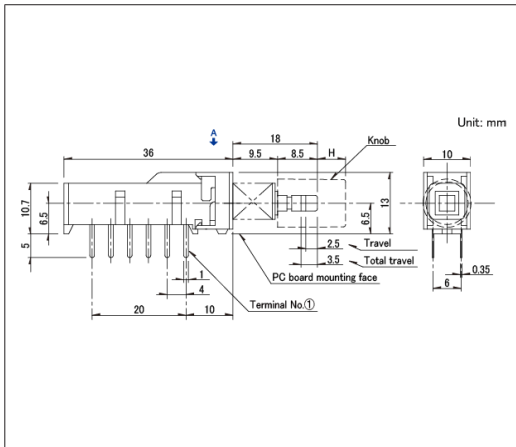

■ Mounting Hole Dimensions

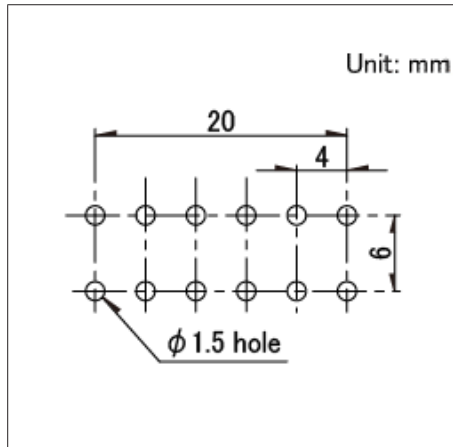

■ Circuit Diagram

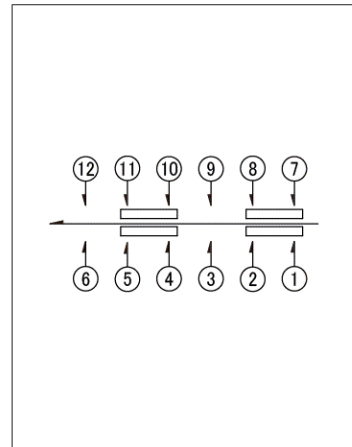

Viewed from direction A in the dimensions.

2.5mm-travel Large-sized Horizontal Type  
**SPUN Series**

**Drawing No.4**

■ Dimensions

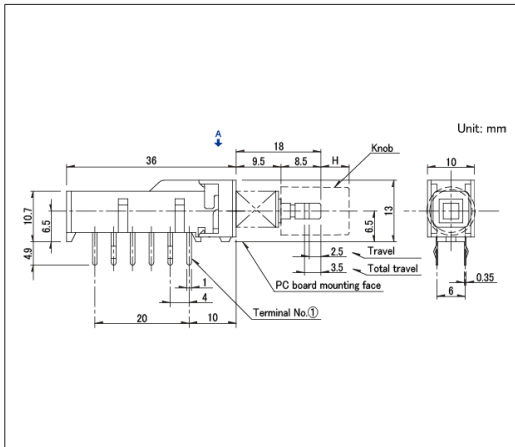

■ Mounting Hole Dimensions

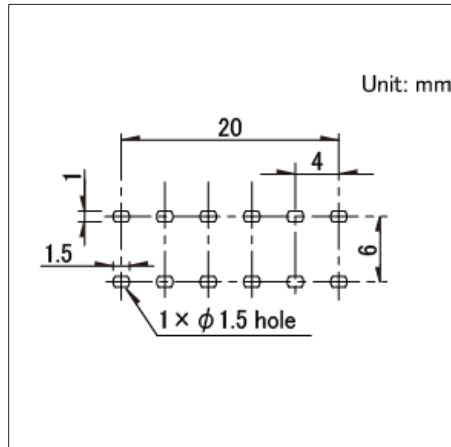

■ Circuit Diagram

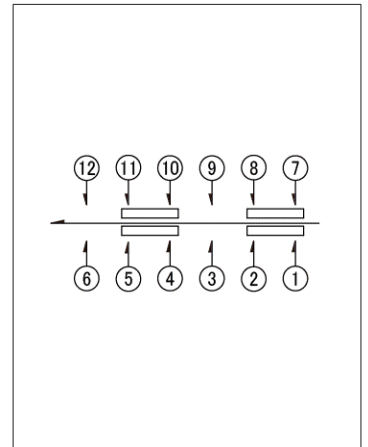

Viewed from direction A in the dimensions.

**Drawing No.5**

■ Dimensions

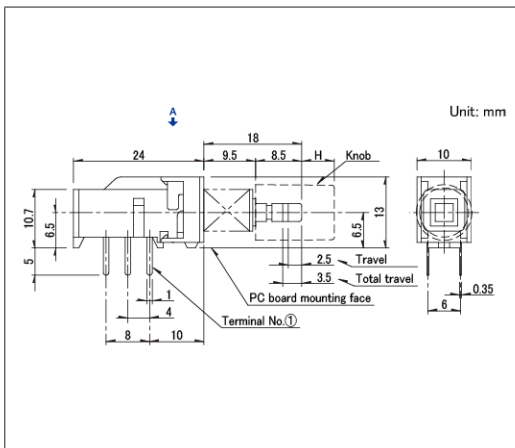

■ Mounting Hole Dimensions

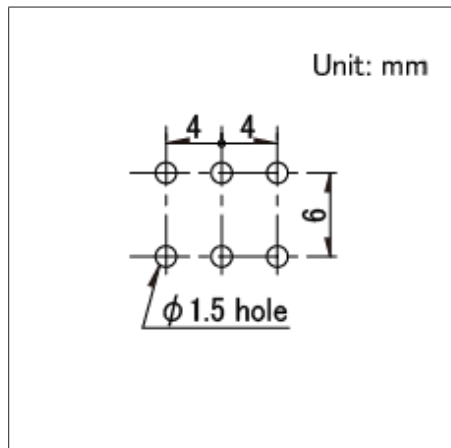

■ Circuit Diagram

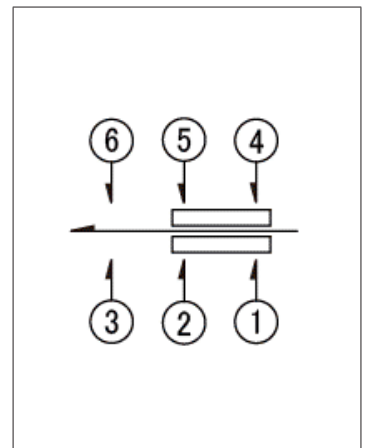

Viewed from direction A in the dimensions.

# Switches Push Switches

## Compact Momentary Type SPEJ Series

Dual-circuit, dual-contact momentary action with a satisfying click feel.

 Automotive



- Rating (max.)/(min.) (Resistive load): 0.2A 14V DC / -
- Contact resistance (Initial performance/After lifetime):  
150mΩ max./150mΩ max.
- Operating life without load: 10,000 cycles 150mΩ max.
- Operating life with load (at max. rated load): 10,000 cycles 150mΩ max.

Applications: Automotive: Side Mirror, Power Windows

■ Product List

Products No.	Total travel (mm)	Poles	Positions	Operating force	Dimensions (W×D×H) (mm)	Automotive	Drawing No.
<b>SPEJ110101</b>	1.7	2	2	3.5±0.7N	7.0×7.0×5.95	●	1

 Note

1. This catalog shows only outline specifications. When using the products, please obtain formal specifications for supply.
2. Please place purchase orders for taping products per minimum order unit (1 reel or a case).

■ Packing Specifications

Taping

Number of packages (pcs.)			Tape width (mm)	Export package measurements (mm)
1 reel	1 case / Japan	1 case / export packing		
500	1,000	2,000	24	404 x 397 x 140

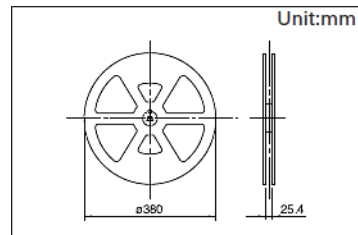

### Drawing No. 1

■ Dimensions

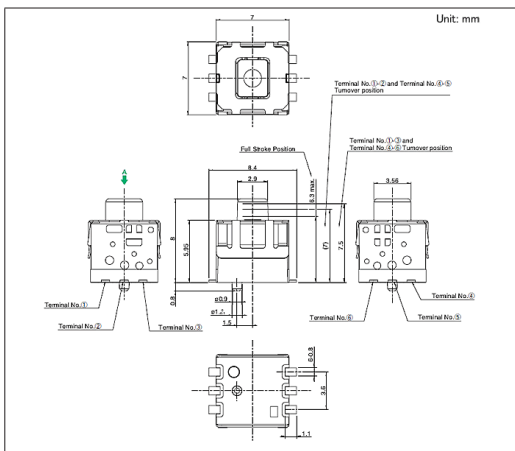

■ Recommend Pattern

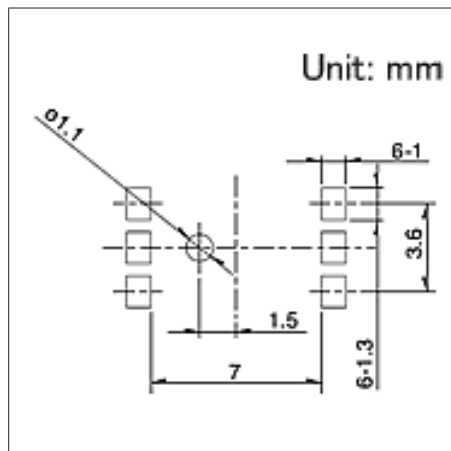

■ Circuit Diagram

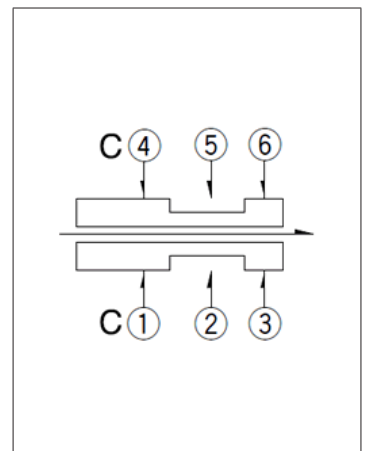

## Switches

## Push Switches

## 2.2mm-travel Medium-sized Vertical Type

**SPPH4 Series**

Medium-sized design prioritizing ease of use.



- Rating (max.)/(min.) (Resistive load): 0.1 A 30V DC/50 $\mu$ A 3V DC
- Contact resistance (Initial performance/After lifetime):  
100m $\Omega$  max. (Initial performance)
- Operating life without load: 10,000 cycles 100m $\Omega$  max.
- Operating life with load (at max. rated load): 10,000 cycles 100m $\Omega$  max.

Applications: Audio\_TV: Visual, Audio, Pro audio

## ■ Product List

Products No.	Travel (mm)	Total travel (mm)	Poles	Operating force	Changeover timing	Mounting method	Operation	Terminal type	Location lug	Dimensions (W×D×H) (mm)	Automotive	Drawing No.
SPPH410100	2.2	3.0	2	2 $\pm$ 1N	Non shorting	PC board	Latching	Straight	With	8.5×6.5×8.5	—	1
SPPH410200	2.2	3.0	2	2 $\pm$ 1N	Non shorting	PC board	Momentary	Straight	With	8.5×6.5×8.5	—	
SPPH420100	2.2	3.0	2	2 $\pm$ 1N	Non shorting	PC board	Latching	Straight	Without	8.5×6.5×8.5	—	2
SPPH430100	2.2	3.0	2	2 $\pm$ 1N	Non shorting	PC board	Latching	Snap-in	With	8.5×6.5×8.5	—	3
SPPH430200	2.2	3.0	2	2 $\pm$ 1N	Non shorting	PC board	Momentary	Snap-in	With	8.5×6.5×8.5	—	

## ⚠ Note

1. This catalog shows only outline specifications. When using the products, please obtain formal specifications for supply.
2. Please place purchase orders per minimum order unit (integer).

## ■ Packing Specifications

Bulk

Number of packages (pcs.)		Export package measurements (mm)
1 case / Japan	1 case / export packing	
1,200	6,000	400 x 270 x 290

## Drawing No. 1

## ■ Dimensions

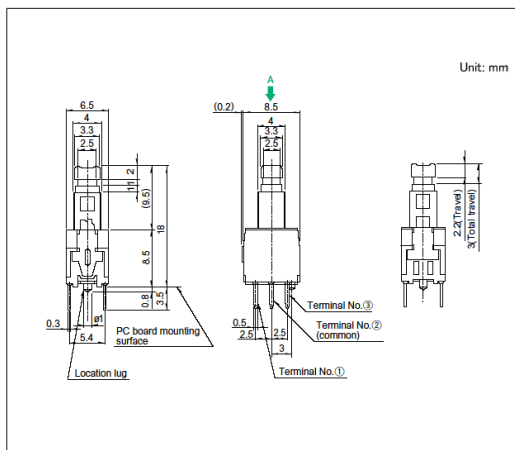

## ■ Mounting Hole Dimensions

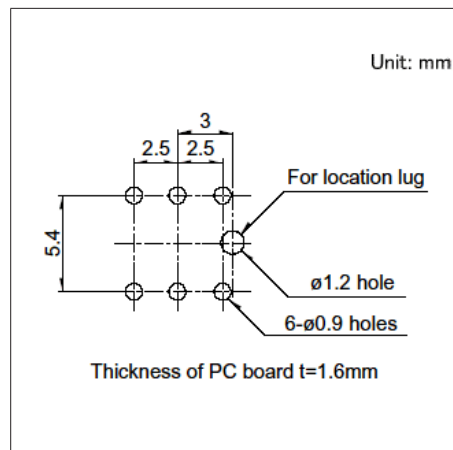

## ■ Circuit Diagram

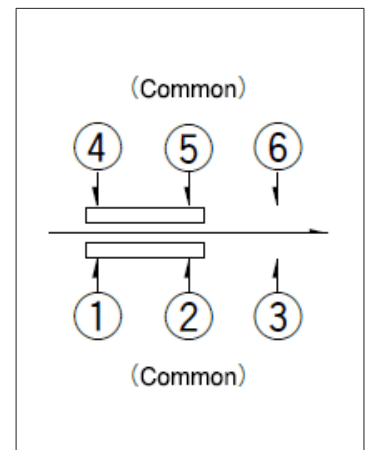

Viewed from direction A in the dimensions.

2.2mm-travel Medium-sized Vertical Type  
SPPH4 Series

Drawing No.2

■ Dimensions

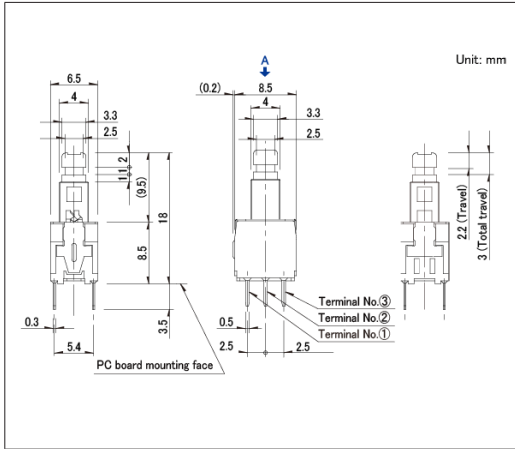

■ Mounting Hole Dimensions

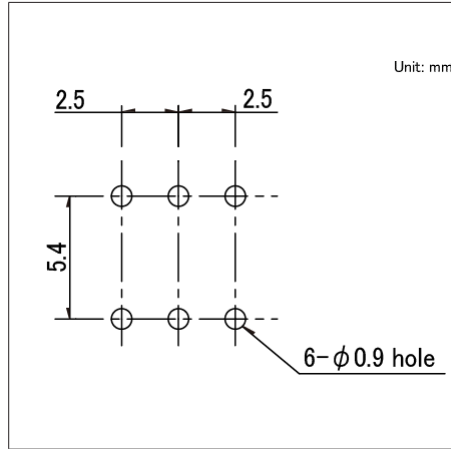

■ Circuit Diagram

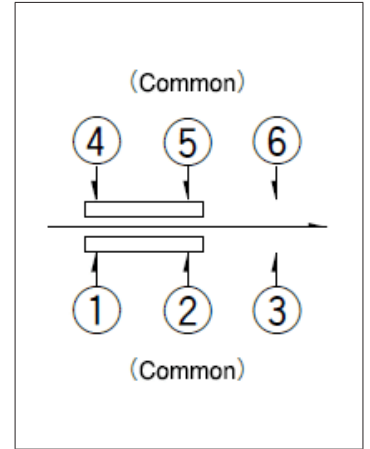

Viewed from direction A in the dimensions.

Drawing No.3

■ Dimensions

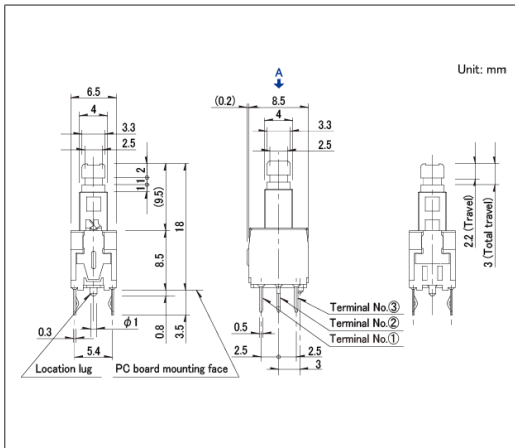

■ Mounting Hole Dimensions

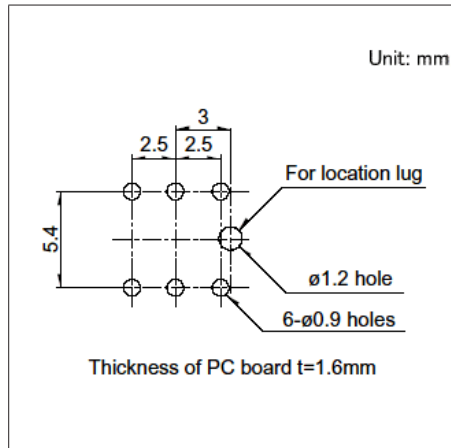

■ Circuit Diagram

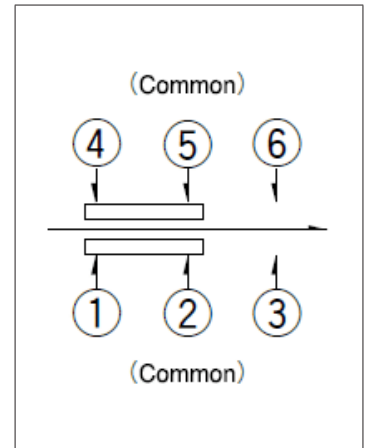

Viewed from direction A in the dimensions.

## 1.5mm-travel Vertical Type SPPH1 Series

Offers a lineup of two types of knob shapes.

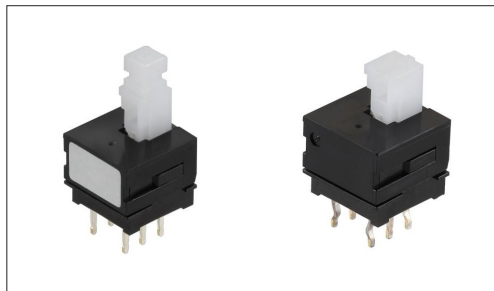

 Automotive

- Rating (max.)/(min.) (Resistive load): 0.1 A 30V DC/50 $\mu$ A 3V DC
- Contact resistance (Initial performance/After lifetime):  
20m $\Omega$  max./40m $\Omega$  max.
- Operating life without load: 10,000 cycles 40m $\Omega$  max.
- Operating life with load (at max. rated load): 10,000 cycles 40m $\Omega$  max.

Applications: Audio\_TV: Visual, Audio, Pro audio  
Automotive: Navigation/audio systems, HVAC

### Product List

Products No.	Travel (mm)	Total travel (mm)	Poles	Operating force	Changeover timing	Mounting method	Operation	Terminal type	Dimensions (W×D×H) (mm)	Automotive	Drawing No.
SPPH110800	1.5	2.5	2	2 (+1, -0.7) N	Non shorting	PC board	Latching	Straight	10.0×10.0×8.5	●	1
SPPH110300	1.5	2.5	2	2 (+1, -0.7) N	Non shorting	PC board	Momentary	Straight	10.0×10.0×8.5	●	2
SPPH120400	1.5	2.5	2	2 (+1, -0.7) N	Non shorting	PC board	Latching	Straight	10.0×10.0×8.5	●	3
SPPH120100	1.5	2.5	2	2 (+1, -0.7) N	Non shorting	PC board	Momentary	Straight	10.0×10.0×8.5	●	4
SPPH130400	1.5	2.5	2	2 (+1, -0.7) N	Non shorting	PC board	Latching	Snap-in	10.0×10.0×8.5	●	5
SPPH130100	1.5	2.5	2	2 (+1, -0.7) N	Non shorting	PC board	Momentary	Snap-in	10.0×10.0×8.5	●	6
SPPH140300	1.5	2.5	2	2 (+1, -0.7) N	Non shorting	PC board	Latching	Snap-in	10.0×10.0×8.5	●	7
SPPH140100	1.5	2.5	2	2 (+1, -0.7) N	Non shorting	PC board	Momentary	Snap-in	10.0×10.0×8.5	●	8
SPPH110900	1.5	2.5	2	3 (+1, -0.7) N	Non shorting	PC board	Latching	Straight	10.0×10.0×8.5	●	9
SPPH130500	1.5	2.5	2	3 (+1, -0.7) N	Non shorting	PC board	Latching	Snap-in	10.0×10.0×8.5	●	10
SPPH140400	1.5	2.5	2	3 (+1, -0.7) N	Non shorting	PC board	Latching	Snap-in	10.0×10.0×8.5	●	11

### Note

1. This catalog shows only outline specifications. When using the products, please obtain formal specifications for supply.
2. Please place purchase orders per minimum order unit (integer).
3. This products can be used in vehicles.

Although these products are designed to perform over a wide operating temperature range, please ensure that you receive and read the formal delivery specifications before use.

### Packing Specifications

Bulk

Number of packages (pcs.)		Export package measurements (mm)
1 case / Japan	1 case / export packing	
800	4,000	400 x 270 x 290

1.5mm-travel Vertical Type  
SPPH1 Series

Drawing No.1

■ Dimensions

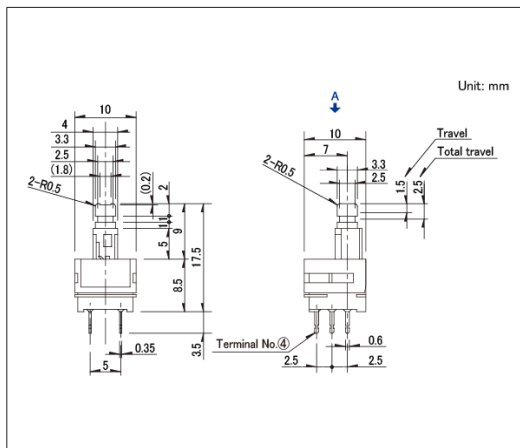

■ Mounting Hole Dimensions

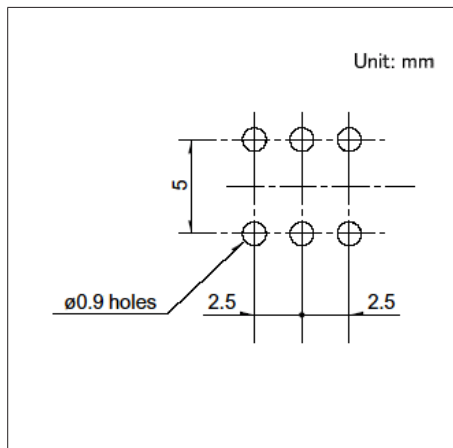

■ Circuit Diagram

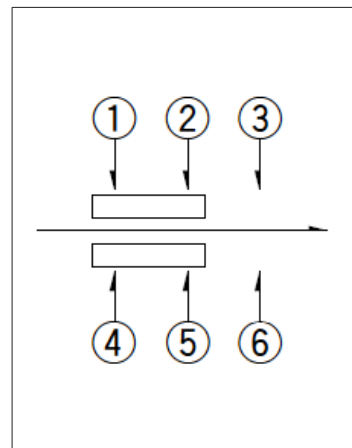

Viewed from direction A in the dimensions.

Drawing No.2

■ Dimensions

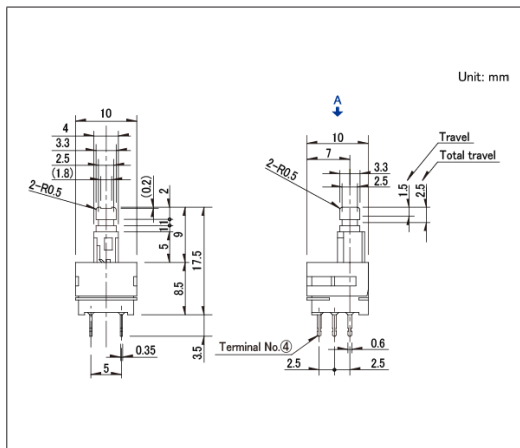

■ Mounting Hole Dimensions

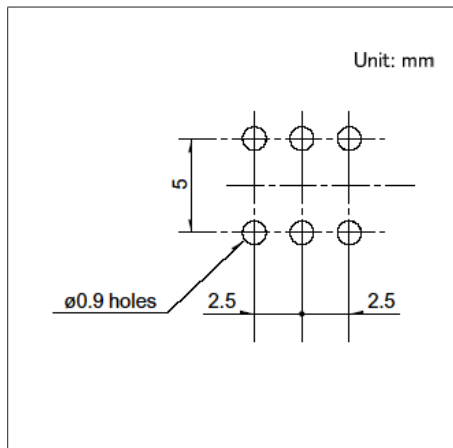

■ Circuit Diagram

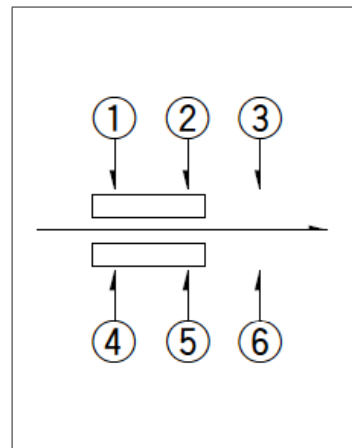

Viewed from direction A in the dimensions.

Drawing No.3

■ Dimensions

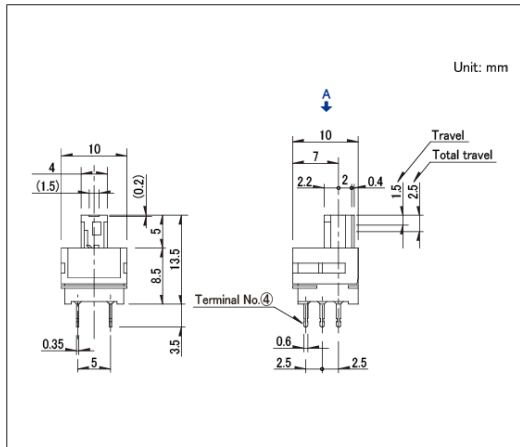

■ Mounting Hole Dimensions

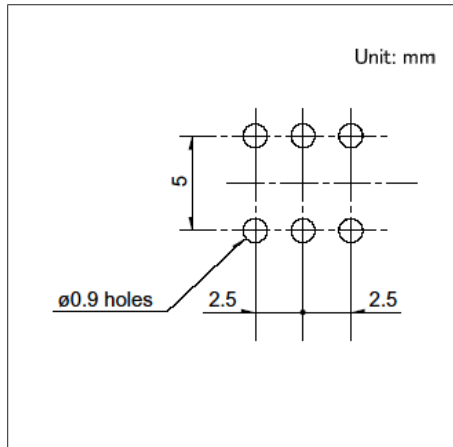

■ Circuit Diagram

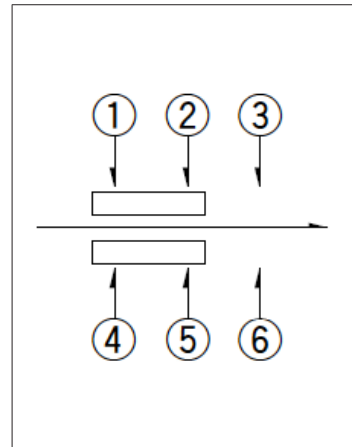

Viewed from direction A in the dimensions.

1.5mm-travel Vertical Type  
**SPPH1 Series**

**Drawing No.4**

■ Dimensions

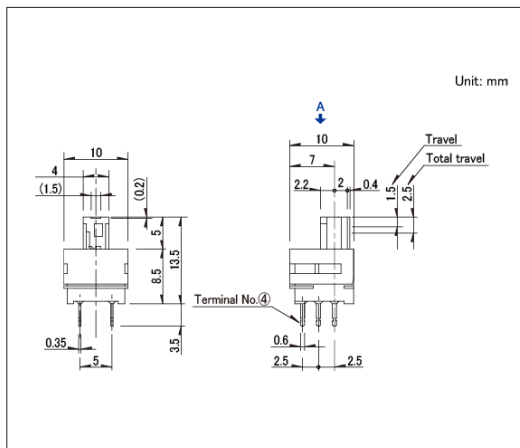

■ Mounting Hole Dimensions

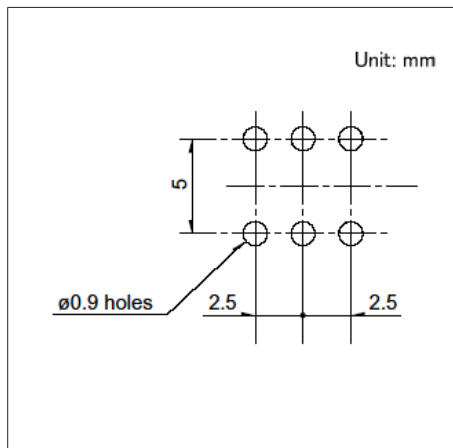

■ Circuit Diagram

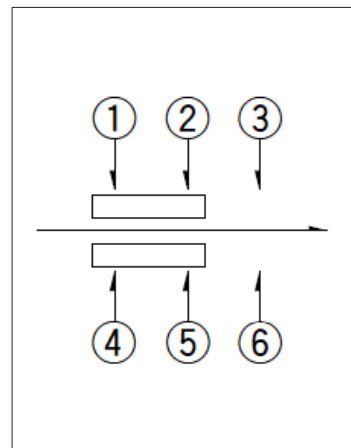

Viewed from direction A in the dimensions.

**Drawing No.5**

■ Dimensions

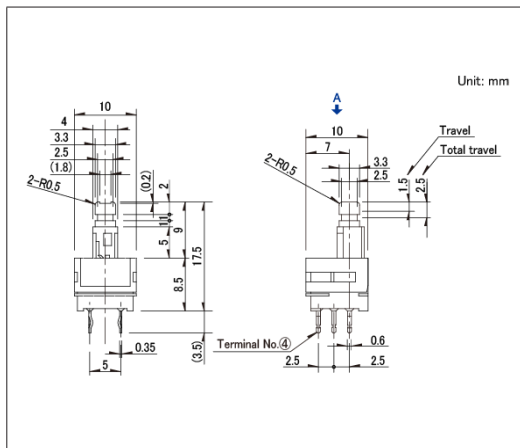

■ Mounting Hole Dimensions

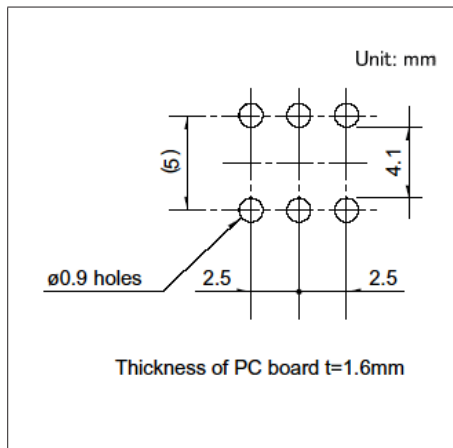

■ Circuit Diagram

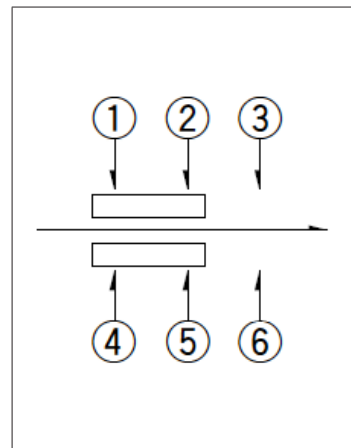

Viewed from direction A in the dimensions.

**Drawing No.6**

■ Dimensions

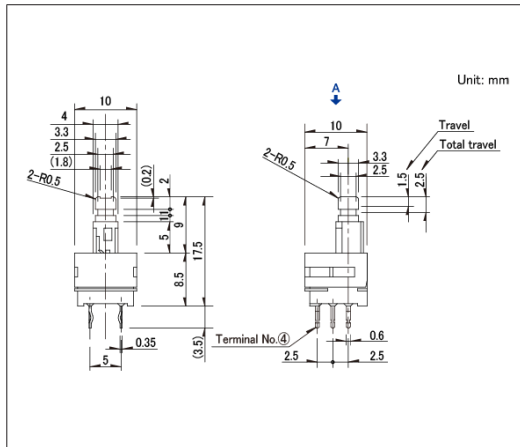

■ Mounting Hole Dimensions

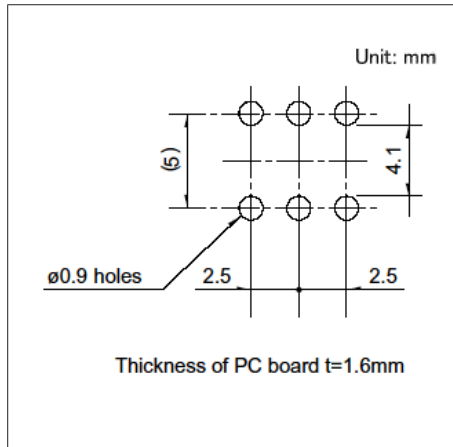

■ Circuit Diagram

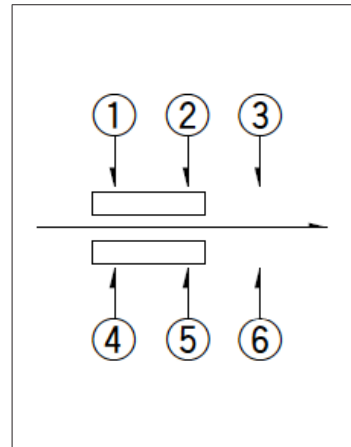

Viewed from direction A in the dimensions.

1.5mm-travel Vertical Type  
SPPH1 Series

Drawing No.7

■ Dimensions

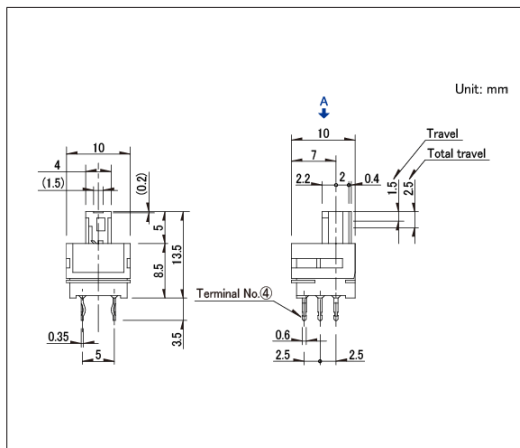

■ Mounting Hole Dimensions

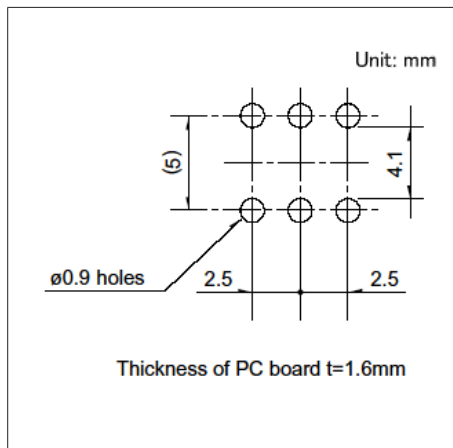

■ Circuit Diagram

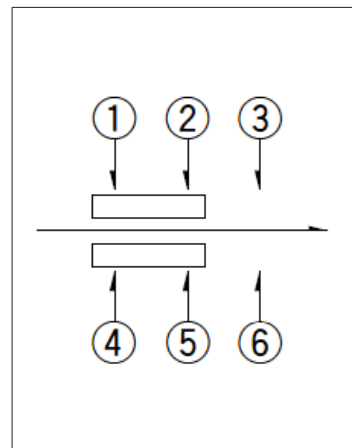

Viewed from direction A in the dimensions.

Drawing No.8

■ Dimensions

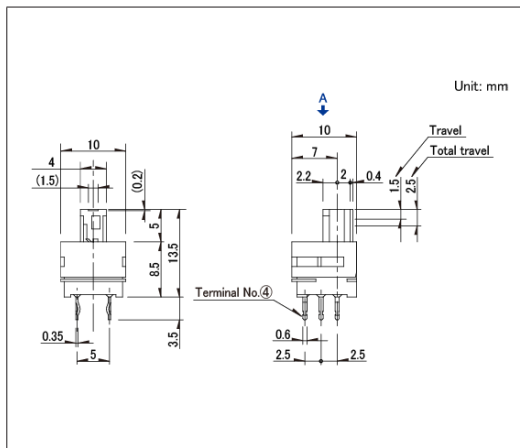

■ Mounting Hole Dimensions

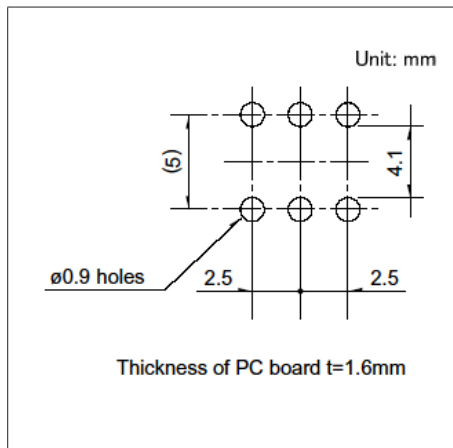

■ Circuit Diagram

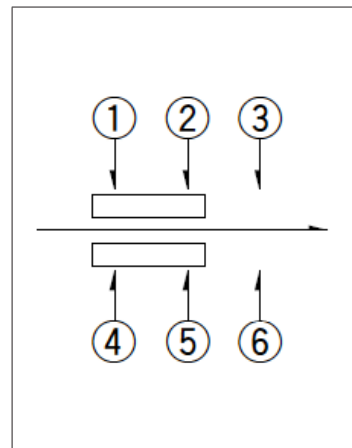

Viewed from direction A in the dimensions.

Drawing No.9

■ Dimensions

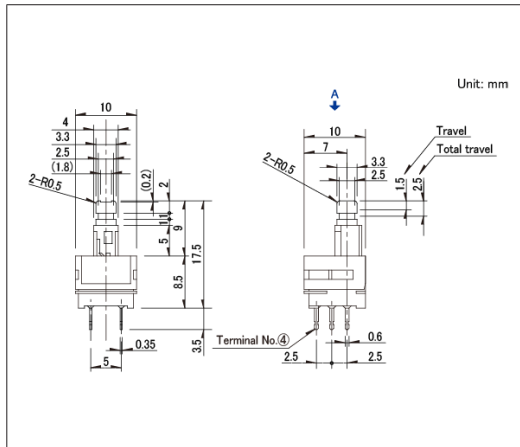

■ Mounting Hole Dimensions

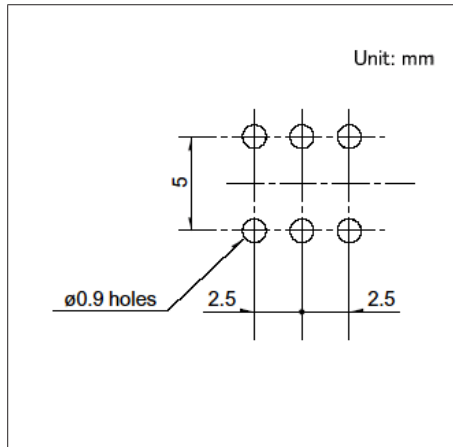

■ Circuit Diagram

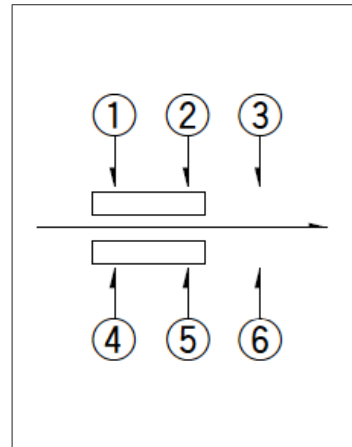

Viewed from direction A in the dimensions.

1.5mm-travel Vertical Type  
SPPH1 Series

Drawing No.10

■ Dimensions

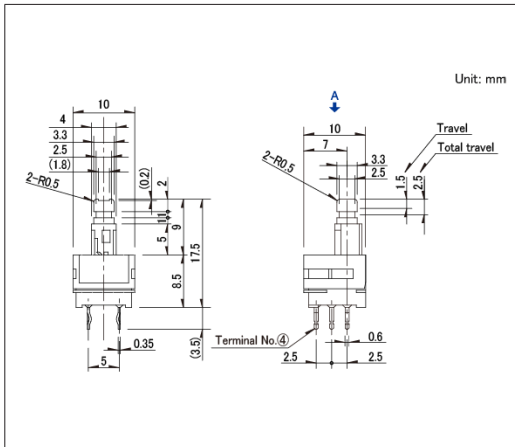

■ Mounting Hole Dimensions

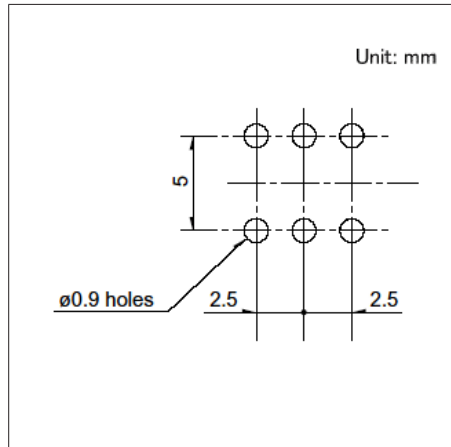

■ Circuit Diagram

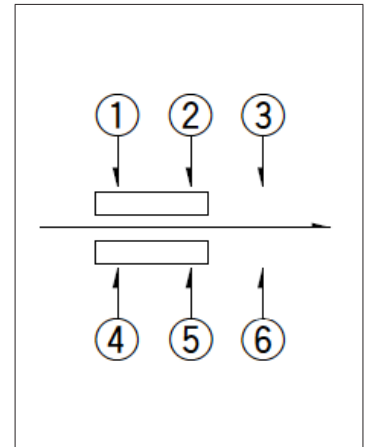

Viewed from direction A in the dimensions.

Drawing No.11

■ Dimensions

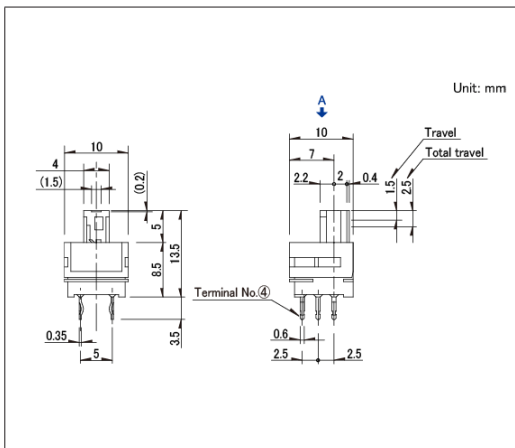

■ Mounting Hole Dimensions

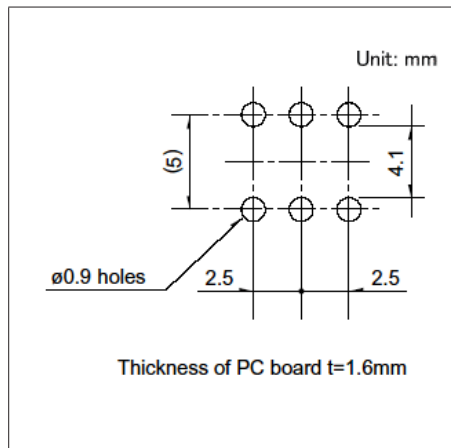

■ Circuit Diagram

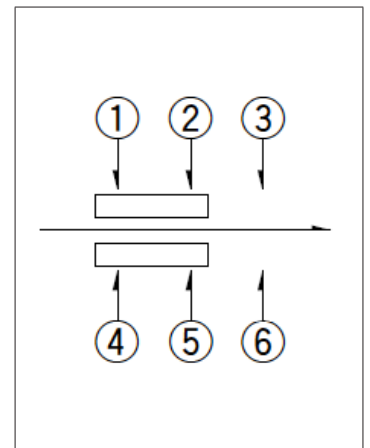

Viewed from direction A in the dimensions.

## Switches

## Push Switches

1.5mm-travel Vertical Type  
**SPEF Series**

Supports surface mounting with lead-free solder.

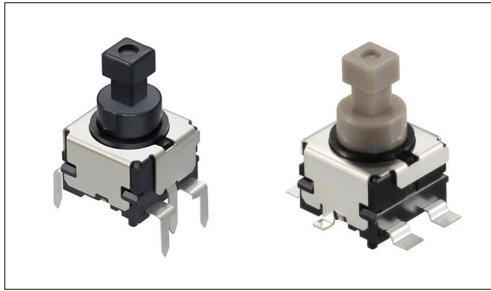

Automotive

- Rating (max.)/(min.) (Resistive load): 1A 14.5V DC/50 $\mu$ A 3V DC
- Contact resistance (Initial performance/After lifetime): 100m $\Omega$  max./1 $\Omega$  max.
- Operating life with load (at max. rated load): 30,000 cycles 100m $\Omega$  max.

Applications: Automotive: Map Lamp, Hazard Lights

## Product List

Products No.	Travel (mm)	Total travel (mm)	Poles	Positions	Operating force	Changeover timing	Mounting method	Operation	Terminal type	Dimensions (W×D×H) (mm)	Automotive	Drawing No.
SPEF210101	1.5	2.7	1	2	3N	Non shorting	PC board	Latching	Reflow	9.4×9.0×6.9	●	1
SPEF110100	1.5	2.7	1	2	3N	Non shorting	PC board	Latching	Dip	9.4×9.0×6.9	●	2
SPEF210200	1.5	2.7	1	2	5N	Non shorting	PC board	Latching	Reflow	9.4×9.0×6.9	●	1
SPEF110200	1.5	2.7	1	2	5N	Non shorting	PC board	Latching	Dip	9.4×9.0×6.9	●	2
SPEF220100	—	2.7	1	2	3N	Non shorting	PC board	Alternate	Reflow	9.4×9.0×6.9	●	3
SPEF120100	—	2.7	1	2	3N	Non shorting	PC board	Alternate	Dip	9.4×9.0×6.9	●	4
SPEF220200	—	2.7	1	2	5N	Non shorting	PC board	Alternate	Reflow	9.4×9.0×6.9	●	3
SPEF120200	—	2.7	1	2	5N	Non shorting	PC board	Alternate	Dip	9.4×9.0×6.9	●	4

## Note

- This catalog shows only outline specifications. When using the products, please obtain formal specifications for supply.
- Please place purchase orders per minimum order unit (integer).
- This products can be used in vehicles.

Although these products are designed to perform over a wide operating temperature range, please ensure that you receive and read the formal delivery specifications before use.

## Packing Specifications

## Taping

Products No.	Number of packages(pcs.)			Tape width (mm)	Export package measurements (mm)
	1 reel	1 case / Japan	1 case / export packing		
SPEF210101 SPEF210200 SPEF220100 SPEF220200	165	660	1,320	32	403×403×360

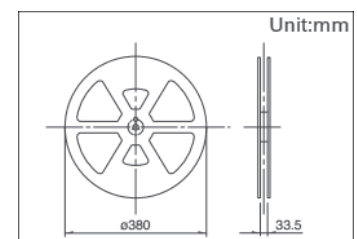

## Tray

Products No.	Number of packages(pcs.)		Export package measurements (mm)
	1 case / Japan	1 case / export packing	
SPEF110100 SPEF110200 SPEF120100 SPEF120200	1,050	4,200	540 x 360 x 230





Switches Push Switches

4.5mm-travel Push-push Type  
**SPED2 Series**

Provides smooth and linear operation feel.

Automotive

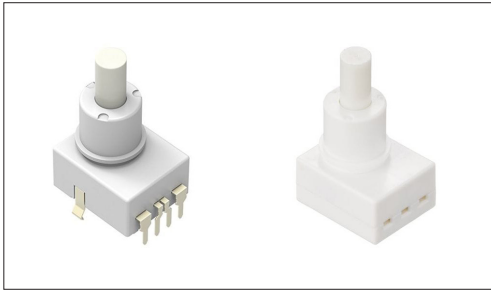

- Rating (max.)/(min.) (Resistive load): 1A 14.5V DC / -
- Contact resistance (Initial performance/After lifetime):  
100mΩ max./100mΩ max.
- Operating life with load (at max. rated load): 30,000 cycles 100mΩ max.

Applications: Automotive: Map Lamp

■ Product List

Products No.	Total travel (mm)	Poles	Positions	Operating force	Changeover timing	Mounting method	Operation	Terminal type	Dimensions (W×D×H) (mm)	Automotive	Drawing No.
SPED220200	4.5	2	1	4.17±0.74N	Non shorting	PC board	Alternate	For PC board	16.8×14.0×9.5	●	1
SPED210203	4.5	1	2	4.17±0.74N	Non shorting	Connector	Alternate	—	16.8×14.0×9.5	●	2

Note

1. This catalog shows only outline specifications. When using the products, please obtain formal specifications for supply.
2. Please place purchase orders per minimum order unit (integer).
3. This products can be used in vehicles.

Although these products are designed to perform over a wide operating temperature range, please ensure that you receive and read the formal delivery specifications before use.

■ Packing Specifications

Tray

Products No.	Number of packages(pcs.)		Export package measurements (mm)
	1 case / Japan	1 case / export packing	
SPED220200	280	1,120	555 x 375 x 223

Bulk

Products No.	Number of packages(pcs.)		Export package measurements (mm)
	1 case / Japan	1 case / export packing	
SPED210203	400	2,000	400 x 270 x 290

Drawing No. 1

■ Dimensions

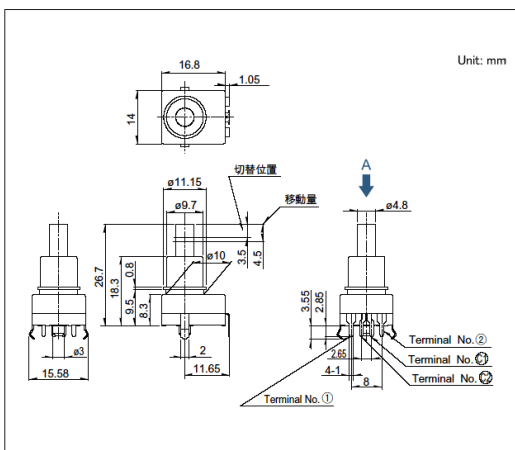

■ Mounting Hole Dimensions

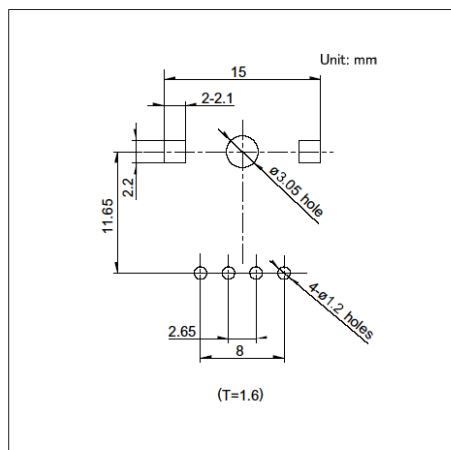

Viewed from direction A in the dimensions.

■ Circuit Diagram

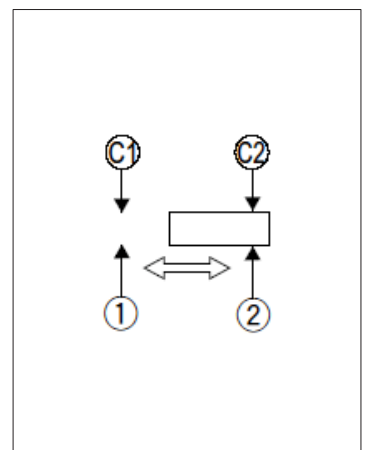

Factory setting for contact points can be either 1 or 2.

4.5mm-travel Push-push Type  
**SPED2 Series**

**Drawing No.2**

■ Dimensions

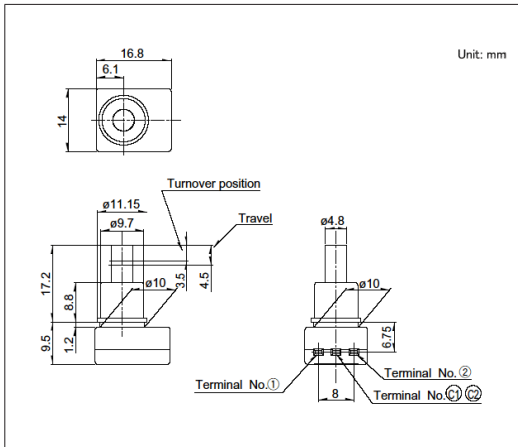

■ Circuit Diagram

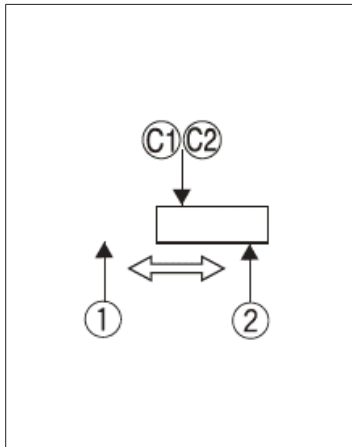

Factory setting for contact points can be either 1 or 2.

Switches Push Switches

# 3.8mm-travel Push-push Type SPED3 Series

Provides smooth and linear operation feel.

Automotive

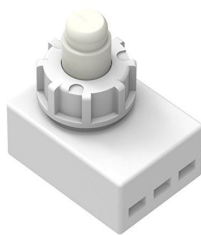

- Rating (max.)/(min.) (Resistive load): 2A 14.5V DC/ -
- Contact resistance (Initial performance/After lifetime):  
100mΩ max./100mΩ max.
- Operating life with load (at max. rated load): 30,000 cycles 100mΩ max.

Applications: Automotive: Map Lamp

■ Product List

Products No.	Total travel (mm)	Poles	Positions	Operating force	Changeover timing	Mounting method	Operation	Dimensions (W×D×H) (mm)	Automotive	Drawing No.
SPED310200	3.8	1	2	4.17±0.74N	Non shorting	Connector	Alternate	18.0×14.0×7.4	●	1

Note

1. This catalog shows only outline specifications. When using the products, please obtain formal specifications for supply.
2. Please place purchase orders per minimum order unit (integer).
3. This products can be used in vehicles.  
Although these products are designed to perform over a wide operating temperature range, please ensure that you receive and read the formal delivery specifications before use.

■ Packing Specifications

Bulk

Number of packages (pcs.)		Export package measurements (mm)
1 case / Japan	1 case / export packing	
500	2,500	400 x 270 x 290

## Drawing No.1

■ Dimensions

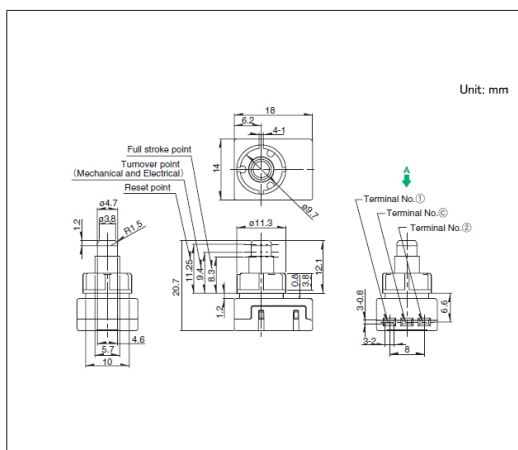

■ Circuit Diagram

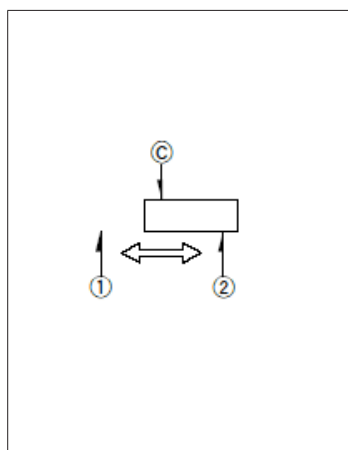

Factory setting for contact points can be either 1 or 2.

Switches Push Switches

3.8mm-travel Push-push Type  
**SPED4 Series**

Provides smooth and linear operation feel.

Automotive

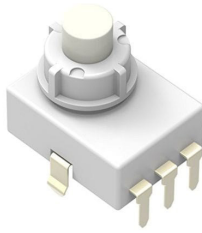

- Rating (max.)/(min.) (Resistive load): 2A 14.5V DC/ -
- Contact resistance (Initial performance/After lifetime):  
100mΩ max./100mΩ max.
- Operating life with load (at max. rated load): 30,000 cycles 100mΩ max.

Applications: Automotive: Map Lamp

■ Product List

Products No.	Total travel (mm)	Poles	Positions	Operating force	Changeover timing	Mounting method	Operation	Terminal type	Dimensions (W×D×H) (mm)	Automotive	Drawing No.
SPED420200	3.8	1	2	4.17±0.74N	Non shorting	PC board	Alternate	For PC board	18.0×14.0×7.27		1

Note

1. This catalog shows only outline specifications. When using the products, please obtain formal specifications for supply.
2. Please place purchase orders per minimum order unit (integer).
3. This products can be used in vehicles.  
Although these products are designed to perform over a wide operating temperature range, please ensure that you receive and read the formal delivery specifications before use.

■ Packing Specifications

Tray

Number of packages (pcs.)		Export package measurements (mm)
1 case / Japan	1 case / export packing	
280	1,120	555 x 375 x 223

Drawing No.1

■ Dimensions

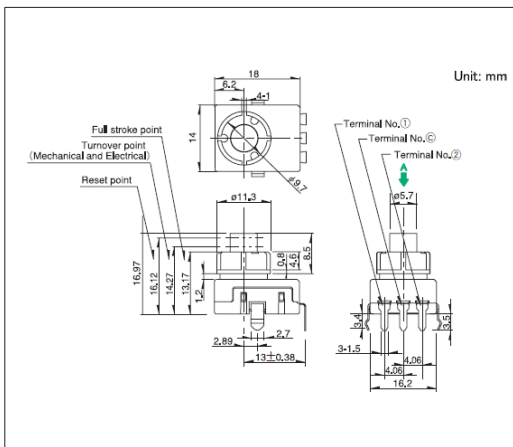

■ Mounting Hole Dimensions

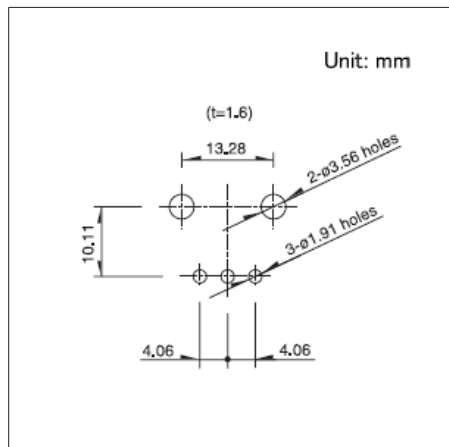

Viewed from direction A in the dimensions.

■ Circuit Diagram

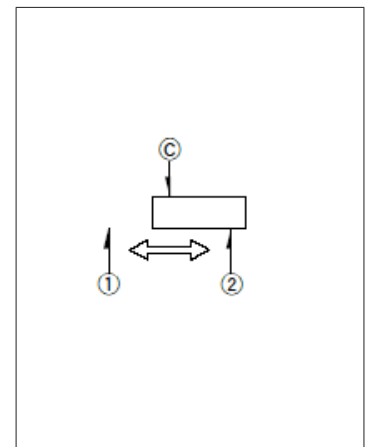

Factory setting for contact points can be either 1 or 2.

## Push Switches / Soldering Conditions

### ■ Example of Reflow Soldering Condition

1. Heating method: Double heating method with infrared heater.
2. Temperature measurement: Thermocouple  $\phi$  0.1 to 0.2 CA (K) or CC (T) at soldering portion (copper foil surface).  
A heat resisting tape should be used for fixed measurement.
3. Temperature profile

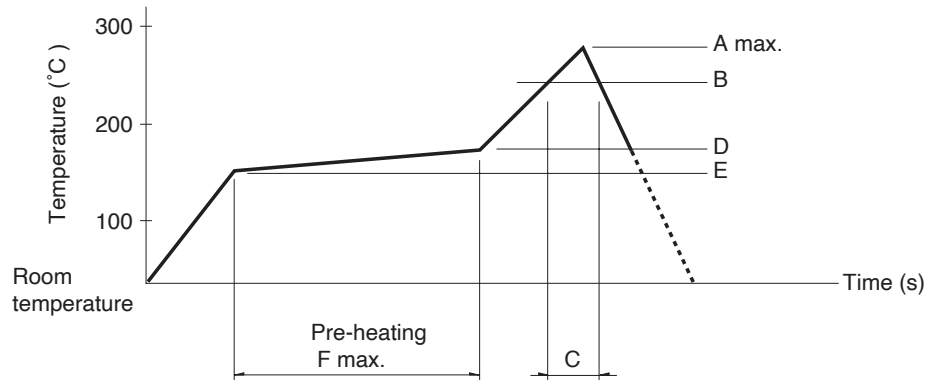

Series (Reflow type)	A (°C) 3s max.	B (°C)	C (s)	D (°C)	E (°C)	F (s)
SPEJ	260	230	40	180	150	120
SPEF						

#### ⚠ Note

1. The condition mentioned above is the temperature on the mounting surface of a PC board. There are cases where the PC board's temperature greatly differs from that of the switch, depending on the PC board's material, size, thickness, etc.  
The above-stated conditions shall also apply to switch surface temperatures.
2. Soldering conditions differ depending on reflow soldering machines. Prior verification of soldering condition is highly recommended.

### ■ Reference for Hand Soldering

Series	Soldering temperature	Soldering time
SPPJ3, SPPJ2, SPUN, SPUJ, SPPH4, SPPH1	350±10°C	3+1/0s
SPED2, SPED4	350±10°C	3±0.5s
SPEJ	350±10°C	4s max.
SPEF	350±5°C	3s max.

### ■ Reference for Dip Soldering

(For PC board terminal types)

Series	Items		Dip soldering	
	Preheating temperature	Preheating time	Soldering temperature	Duration of immersion
SPPJ3	100°C max.	60s max.	260±5°C	5±1s
SPUN	100°C max.	60s max.	260±5°C	10±1s
SPUJ, SPPH4	—		260±5°C	5±1s
SPPJ2, SPPH1, SPED2, SPED4, SPEF	—		260±5°C	10±1s





## Push Switches / Cautions

1. Applying load to terminals during soldering under certain conditions may cause deformation and electrical property degradation.
2. Avoid use of water-soluble soldering flux, since it may corrode the switches.
3. Check and conform to soldering requirements under actual mass production conditions.
4. When soldering twice, wait until the first soldered portion cools to normal temperature. Continuous heating will deform the external portions, loosen or dislodge terminals, or may deteriorate their electrical characteristics.
5. Flux from around and above the PC board should not adhere to the switches.
6. After mounting the switches, if you intend to put the board into an oven in order to harden adhesive for other parts, please consult with us.
7. Before soldering switches with locking mechanism, release the locks. If they are soldered without releasing the locks, the soldering heat may deform the locking mechanism.
8. If you use a through-hole PC board or a PC board thinner or thicker than the recommendation, there may be greater heat stress. Verify the soldering conditions thoroughly before use.
9. Solder the switches with detent at the detent position. Soldering switches fixed at the center of the detent may deform the detent mechanisms.
10. No cleaning.
11. Protect small and thin switches from external forces in the set mounting process.
12. Tighten the mounting screws by applying the specified torque. Tightening with larger torque than the specified one will result in malfunction or breakage of screws.
13. The products are designed and manufactured for direct current resistance. Contact us for use of other resistances such as inductive (L) or capacitive (C).
14. The switch will break if you apply a greater stress than that specified. Take great care not to let the switch be subject to greater stress than specified.
15. Be sure to release the locks before removing the knobs. Otherwise, the locking mechanism may be deformed.
16. Be sure to use the forced travel close to the position of the whole travel as much as possible.
17. Insert these switches to the specified mounting surface and mount them horizontally. If not mounted horizontally, these switches will malfunction.
18. Use of the switches in a dusty environment may lead to dusts entering through the openings and cause imperfect contact or malfunction. Take this into account for set design.
19. Corrosive gas if generated by peripheral parts of a set, malfunction such as imperfect contact may occur. Thorough investigation shall be required beforehand.
20. Storage  
Store the products as delivered at normal temperature and humidity, out of direct sunlight and away from corrosive gases. Use them as soon as possible and no later than six months after delivery.  
Once the seal is broken, use them as soon as possible.

## Switches

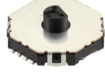
## Rotary Switches

## List of Varieties

Series		SRBD	SRBQ	SRBM	SRBV	
Photo						
Dimensions (mm)		10.0×10.0×1.7	11.4×12.4×3.1 11.4×12.4×3.5	10.0×12.5×11.5 10.0×12.9×11.5	16.2×18.5×7.5	
Changeover angle		36°	40±3°	18±3° 30±3°	30±3°	
Poles		1		1 2	1	
Rotational torque		13±5mN·m	6±3mN·m 13±5mN·m	15±7mN·m 40±20mN·m	30±15mN·m	
Operating temperature range		-25°C to +85°C	-10°C to +60°C	-30°C to +85°C	-10°C to +85°C	
Rating (max.)/(min.) (Resistive load)		1mA 5V DC/50μA 3V DC	0.1A 16V DC/50μA 3V DC		0.3A 16V DC/50μA 3V DC	
Electrical performance	Contact resistance (Initial performance/ After lifetime)	200mΩ max./250mΩ max.	50mΩ max./100mΩ max.	50mΩ max./150mΩ max.		
	Insulation resistance	100MΩ min. 100V DC				
	Voltage proof	100V AC for 1 minute				
Mechanical performance	Terminal strength	3N for 1 minute	5N for 1 minute			
	Actuator strength	Rotational direction	—		0.5N·m	0.6N·m
		Push direction	50N	20N	100N	
Durability	Operating life without load	10,000 cycles 250mΩ max.	10,000 cycles 100mΩ max.	10,000 cycles 100mΩ max. 30,000 cycles 100mΩ max.	10,000 cycles 100mΩ max.	
	Operating life with load (at max. rated load)	10,000 cycles 250mΩ max.	10,000 cycles 100mΩ max.	10,000 cycles 150mΩ max.		
Environmental performance	Cold	-40°C 500h	-20°C 96h	-40°C 96h	-20°C 96h	
	Dry heat	85°C 500h	85°C 96h			
	Damp heat	60°C, 90 to 95%RH 500h	40°C, 90 to 95%RH 96h			
Automotive		—	—	—	—	

 Note

● Indicates applicability to all products in the series, while ○ indicates applicability to some products in the series.

Switches Rotary Switches

Heavy-torque Feel, Low-profile Type  
**SRBD Series**

Mode selector switch capable of up to 10 positions.

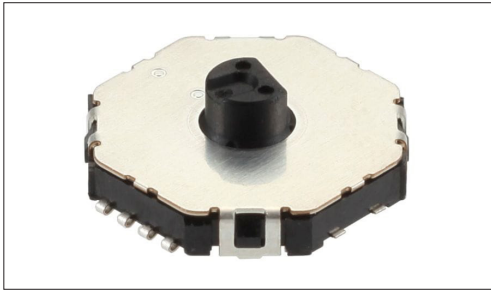

- Rating (max.)/(min.) (Resistive load): 1mA 5V DC/50μA 3V DC
- Contact resistance (Initial performance/After lifetime):  
200mΩ max./250mΩ max.
- Operating life without load: 10,000 cycles 250mΩ max.
- Operating life with load (at max. rated load): 10,000 cycles 250mΩ max.

Applications: Healthcare: Healthcare equipment  
Audio\_TV: Cameras

■ Product List

Products No.	Poles	Positions	Changeover angle	Detent	Location lug	Changeover timing	Rotational torque	Soldering	Actuator length	Dimensions (W×D×H) (mm)	Automotive	Drawing No.
SRBD150201	1	10	36°	5	with	Non shorting	13±5mN·m	For PC board (Reflow)	1.7mm	10.0×10.0×1.7	—	1
SRBD170401	1	10	36°	7	without	Non shorting	13±5mN·m	For PC board (Reflow)	1.7mm	10.0×10.0×1.7	—	2
SRBD180201	1	10	36°	8	with	Non shorting	13±5mN·m	For PC board (Reflow)	1.7mm	10.0×10.0×1.7	—	3
SRBD110401	1	10	36°	10	with	Non shorting	13±5mN·m	For PC board (Reflow)	1.7mm	10.0×10.0×1.7	—	4

**⚠ Note**

1. This catalog shows only outline specifications. When using the products, please obtain formal specifications for supply.
2. Please place purchase orders for taping products per minimum order unit (1 reel or a case).

■ Packing Specifications

Taping

Number of packages (pcs.)			Tape width (mm)	Export package measurements (mm)
1 reel	1 case / Japan	1 case / export packing		
1,200	2,400	4,800	24	428 x 413 x 172

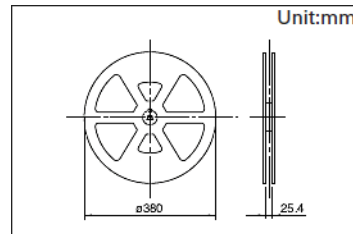

Drawing No.1

■ Dimensions

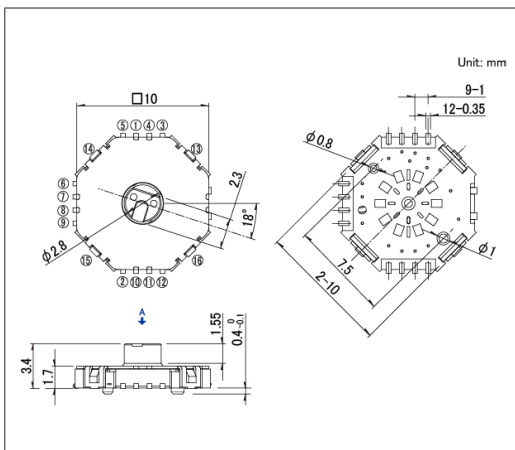

■ Land Dimensions

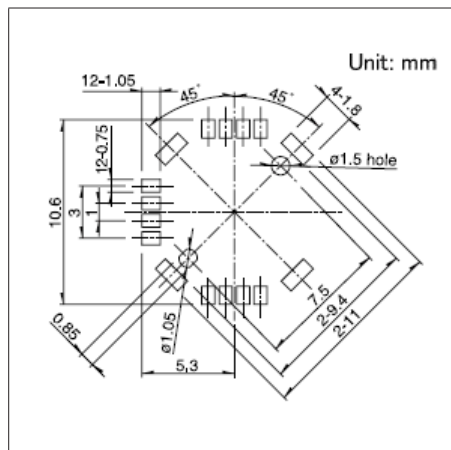

■ Circuit Diagram

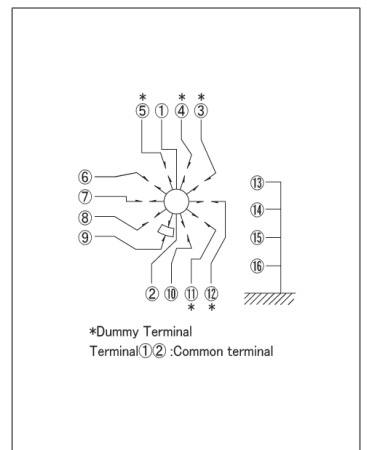

Viewed from direction A in the dimensions.

Switches Rotary Switches

Heavy-torque Feel, Low-profile Type  
SRBD Series

Drawing No.2

■ Dimensions

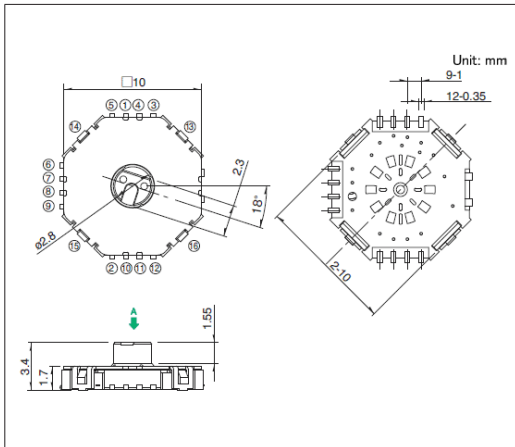

■ Land Dimensions

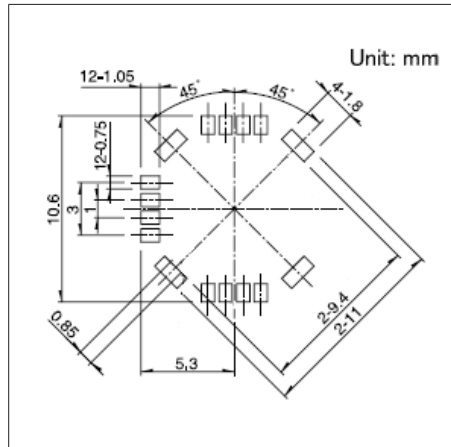

■ Circuit Diagram

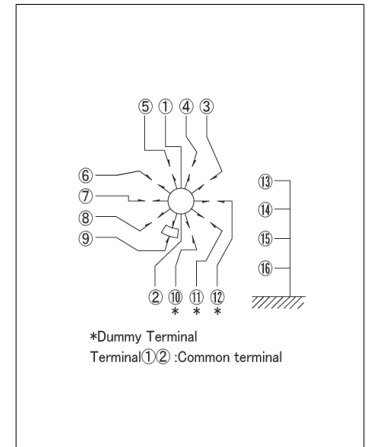

Viewed from direction A in the dimensions.

Drawing No.3

■ Dimensions

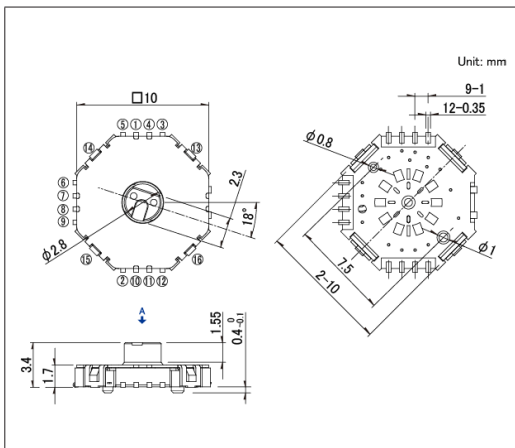

■ Land Dimensions

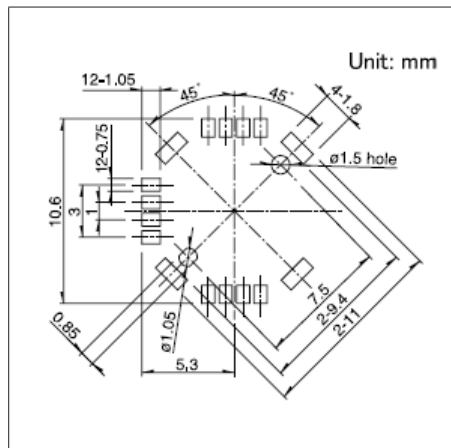

■ Circuit Diagram

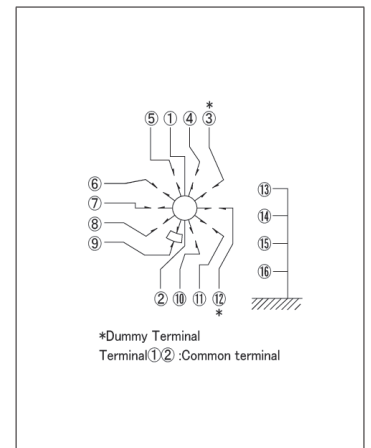

Viewed from direction A in the dimensions.

Drawing No.4

■ Dimensions

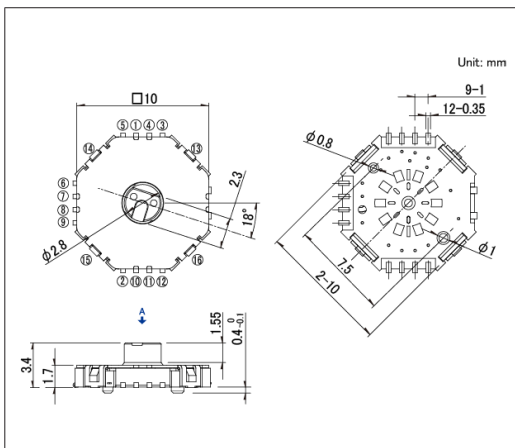

■ Land Dimensions

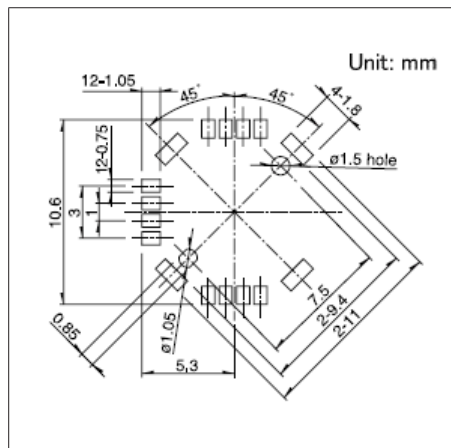

■ Circuit Diagram

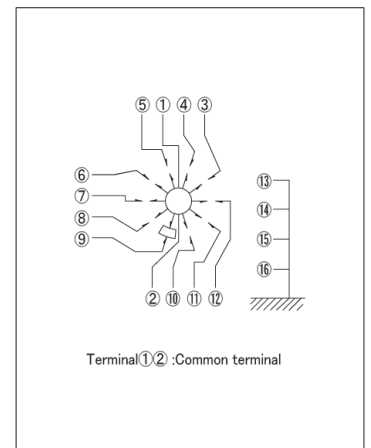

Viewed from direction A in the dimensions.

## Switches Rotary Switches

# 9-positions Low-profile Vertical Type SRBQ Series

Unique detent mechanism delivering a light operation feel with a thin profile.

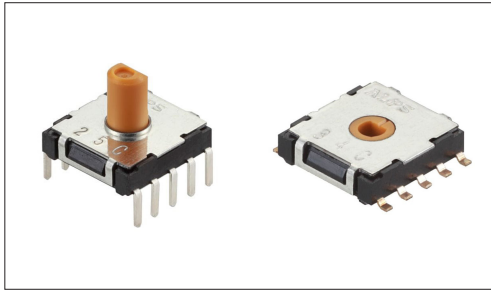

- Rating (max.)/(min.) (Resistive load): 0.1 A 16V DC/50 $\mu$ A 3V DC
- Contact resistance (Initial performance/After lifetime):  
50m $\Omega$  max./100m $\Omega$  max.
- Operating life without load: 10,000 cycles 100m $\Omega$  max.
- Operating life with load (at max. rated load): 10,000 cycles 100m $\Omega$  max.

Applications: Home: Major home appliances

### Product List

Products No.	Poles	Positions	Changeover angle	Changeover timing	Rotational torque	Soldering	Actuator configuration	Actuator length	Dimensions (WxDxH) (mm)	Automotive	Drawing No.
SRBQ090200	1	9	40 $\pm$ 3 $^\circ$	Non shorting	6 $\pm$ 3mN·m	Insertion	Flat	5.8mm	11.4 $\times$ 12.4 $\times$ 3.5	—	1
SRBQ490100	1	9	40 $\pm$ 3 $^\circ$	Non shorting	13 $\pm$ 5mN·m	Insertion	Flat	5.8mm	11.4 $\times$ 12.4 $\times$ 3.5	—	2
SRBQ290301	1	9	40 $\pm$ 3 $^\circ$	Non shorting	6 $\pm$ 3mN·m	Reflow	Non shaft	—	11.4 $\times$ 12.4 $\times$ 3.1	—	3

### ⚠ Note

1. This catalog shows only outline specifications. When using the products, please obtain formal specifications for supply.
2. Please place purchase orders per minimum order unit (integer).
3. Please place purchase orders for taping products per minimum order unit (1 reel or a case).

### Packing Specifications

#### Bulk

Products No.	Number of packages(pcs.)		Export package measurements (mm)
	1 case / Japan	1 case / export packing	
SRBQ090200 SRBQ490100	1,215	4,860	540 x 360 x 290

#### Taping

Products No.	Number of packages(pcs.)			Tape width (mm)	Export package measurements (mm)
	1 reel	1 case / Japan	1 case / export packing		
SRBQ290301	1,200	2,400	4,800	24	406 x 406 x 190

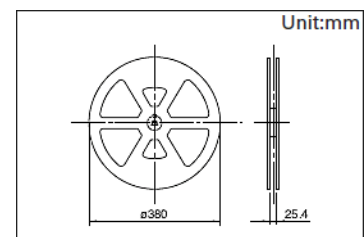

9-positions Low-profile Vertical Type  
SRBQ Series

Drawing No.1

■ Dimensions

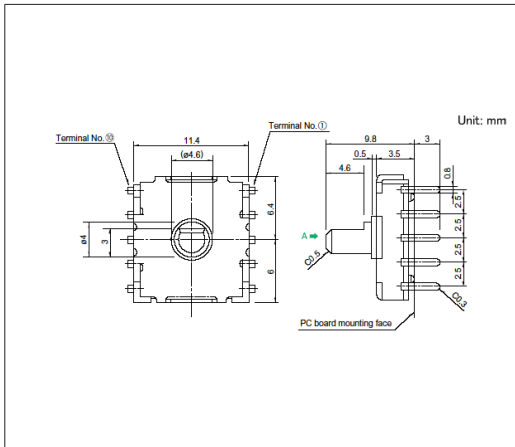

Standard torque

■ Mounting Hole Dimensions

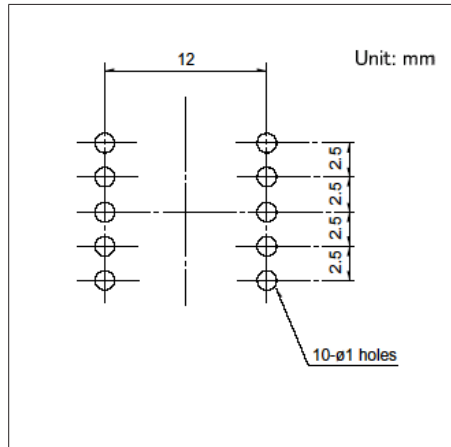

Viewed from direction A in the dimensions.

■ Circuit Diagram

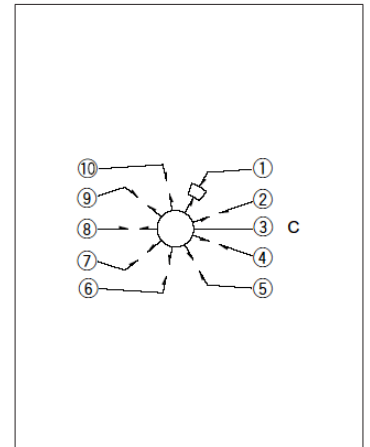

Drawing No.2

■ Dimensions

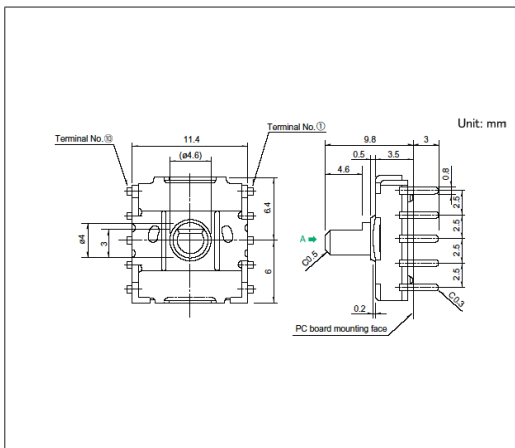

Heavy torque

■ Mounting Hole Dimensions

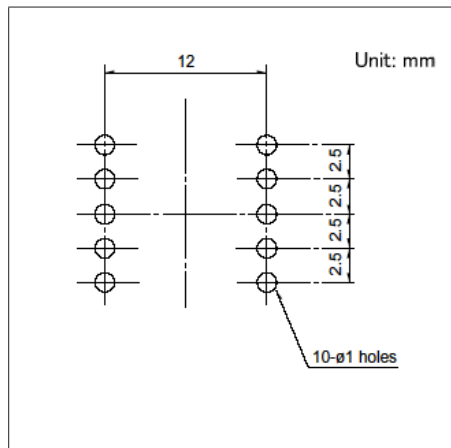

Viewed from direction A in the dimensions.

■ Circuit Diagram

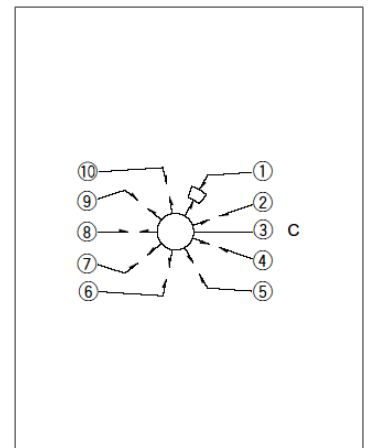

Drawing No.3

■ Dimensions

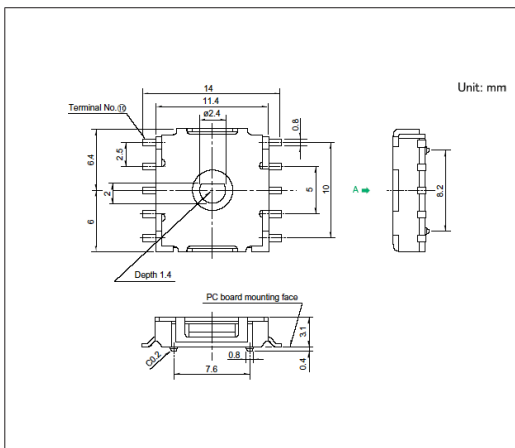

■ Land Dimensions

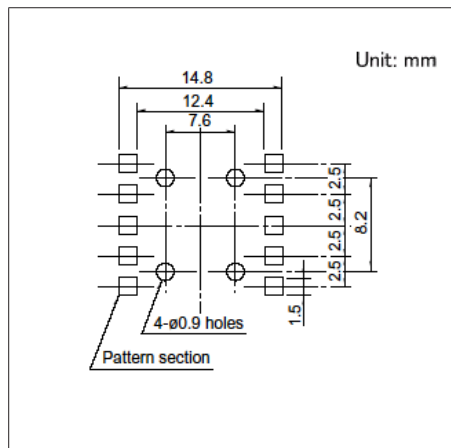

Viewed from direction A in the dimensions.

■ Circuit Diagram

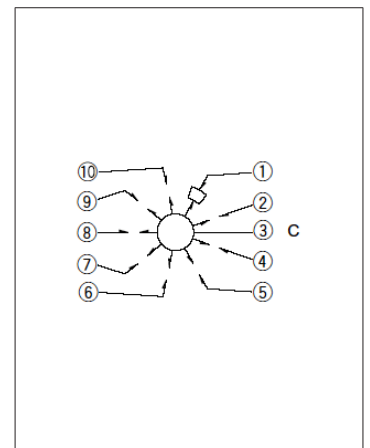

## Switches Rotary Switches

6-positions Horizontal Type  
**SRBM Series**

Same shape available as a pulse switch (20 pulses).

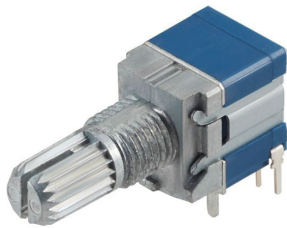

- Rating (max.)/(min.) (Resistive load): 0.1 A 16V DC/50μA 3V DC
- Contact resistance (Initial performance/After lifetime):  
50mΩ max./150mΩ max.
- Operating life without load: 10,000 cycles 100mΩ max.
- Operating life with load (at max. rated load): 10,000 cycles 150mΩ max.

Applications: Energy\_Industrial: Industrial equipment

## ■ Product List

Products No.	Poles	Positions	Changeover angle	Changeover timing	Rotational torque	Actuator configuration	Actuator length	Dimensions (W×D×H) (mm)	Automotive	Drawing No.
SRBM120700	2	2	30±3°	Non shorting	40±20mN·m	18-tooth serration	L: 15mm	10.0×12.5×11.5	—	1
SRBM121300	2	2	30±3°	Non shorting	40±20mN·m	Flat	L: 15mm	10.0×12.5×11.5	—	2
SRBM131300	2	3	30±3°	Non shorting	40±20mN·m	18-tooth serration	L: 15mm	10.0×12.5×11.5	—	3
SRBM131400	2	3	30±3°	Non shorting	40±20mN·m	18-tooth serration	L: 20mm	10.0×12.5×11.5	—	
SRBM140700	2	4	30±3°	Non shorting	40±20mN·m	18-tooth serration	L: 15mm	10.0×12.5×11.5	—	4
SRBM140800	2	4	30±3°	Non shorting	40±20mN·m	18-tooth serration	L: 20mm	10.0×12.5×11.5	—	
SRBM149501	2	4	30±3°	Non shorting	40±20mN·m	Flat	L: 20mm	10.0×12.5×11.5	—	5
SRBM150500	1	5	30±3°	Non shorting	40±20mN·m	18-tooth serration	L: 15mm	10.0×12.5×11.5	—	6
SRBM154002	1	5	30±3°	Non shorting	40±20mN·m	Flat	L: 15mm	10.0×12.5×11.5	—	7
SRBM160700	1	6	30±3°	Non shorting	40±20mN·m	18-tooth serration	L: 15mm	10.0×12.5×11.5	—	8
SRBM1L0800	1	20-pulses	18±3°	—	15±7mN·m	18-tooth serration	L: 15mm	10.0×12.9×11.5	—	9
SRBM1L1400	1	20-pulses	18±3°	—	15±7mN·m	Flat	L: 15mm	10.0×12.9×11.5	—	10

## ⚠ Note

1. This catalog shows only outline specifications. When using the products, please obtain formal specifications for supply.
2. All the axis are die casting shafts.
3. Please place purchase orders per minimum order unit (integer).

## ■ Packing Specifications

Tray

Products No.	Number of packages (pcs.)		Export package measurements (mm)
	1 case / Japan	1 case / export packing	
SRBM120700 SRBM121300 SRBM131300 SRBM140700 SRBM150500 SRBM154002 SRBM160700 SRBM1L0800 SRBM1L1400	360	1,800	400 x 270 x 290
SRBM131400 SRBM140800 SRBM149501	210	1,050	400 x 270 x 290

6-positions Horizontal Type  
SRBM Series

Drawing No.1

■ Dimensions

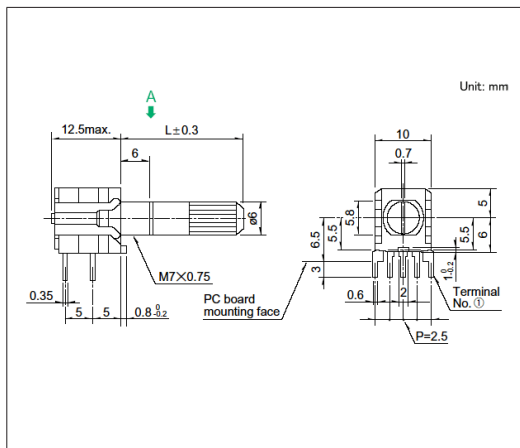

■ Mounting Hole Dimensions

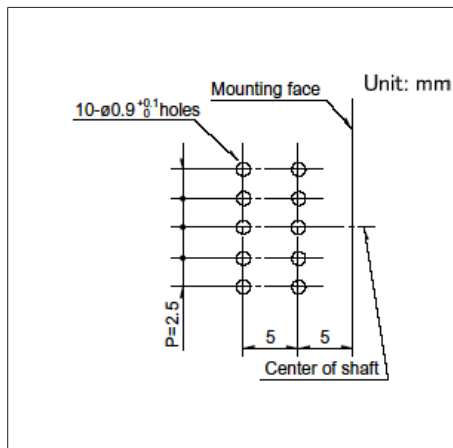

■ Circuit Diagram and Dummy Terminals

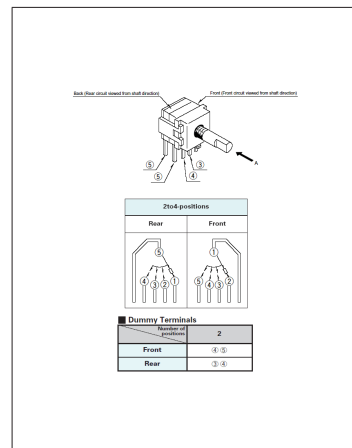

Viewed from direction A in the dimensions.

1. Viewed from direction A.  
2. For positions 2, 1 section consists of 2-poles.

Drawing No.2

■ Dimensions

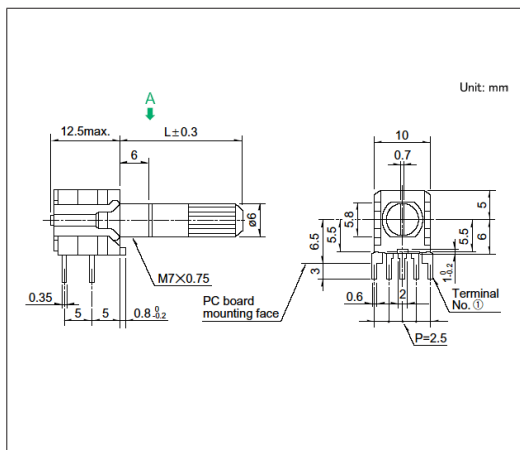

■ Mounting Hole Dimensions

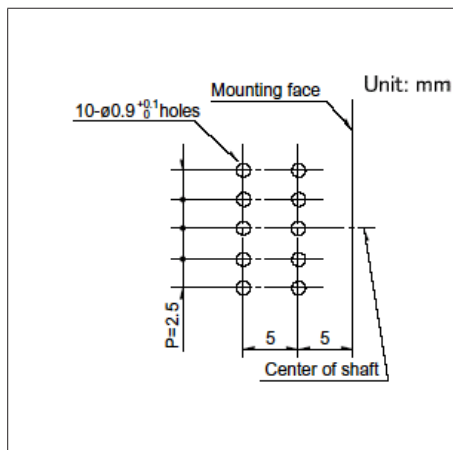

■ Circuit Diagram and Dummy Terminals

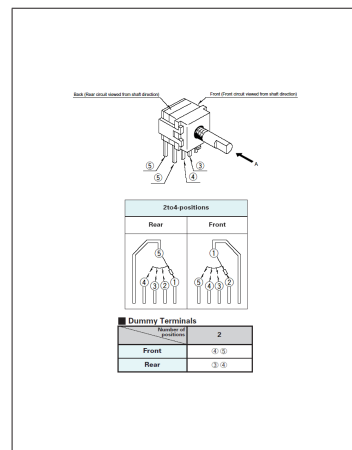

Viewed from direction A in the dimensions.

1. Viewed from direction A.  
2. For positions 2, 1 section consists of 2-poles.

Drawing No.3

■ Dimensions

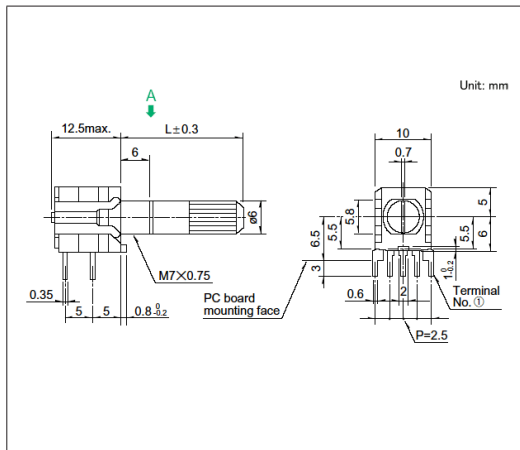

■ Mounting Hole Dimensions

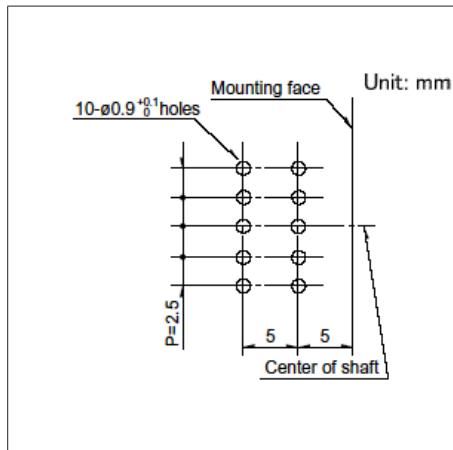

■ Circuit Diagram and Dummy Terminals

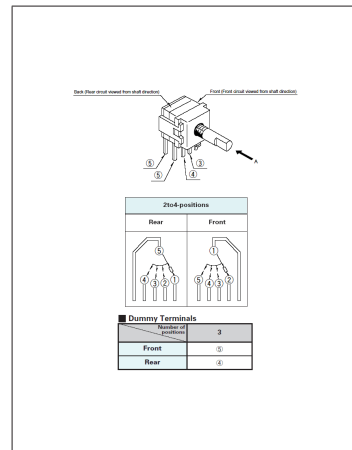

Viewed from direction A in the dimensions.

1. Viewed from direction A.  
2. For positions 3, 1 section consists of 2-poles.

6-positions Horizontal Type  
SRBM Series

Drawing No.4

■ Dimensions

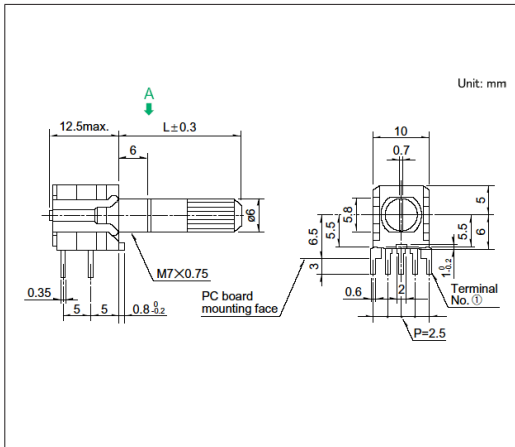

■ Mounting Hole Dimensions

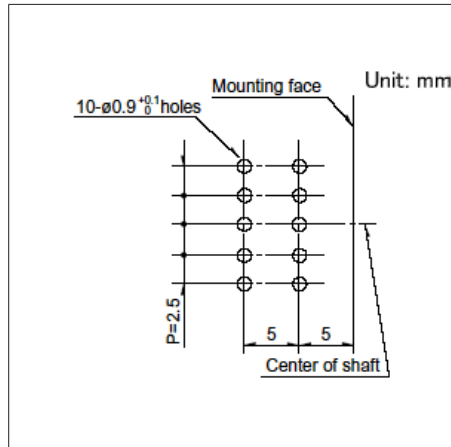

■ Circuit Diagram

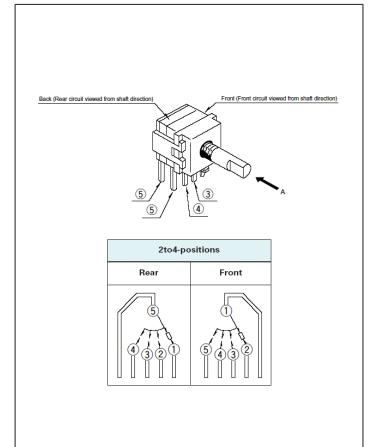

Viewed from direction A in the dimensions.

1. Viewed from direction A.
2. For positions 4, 1 section consists of 2-poles.

Drawing No.5

■ Dimensions

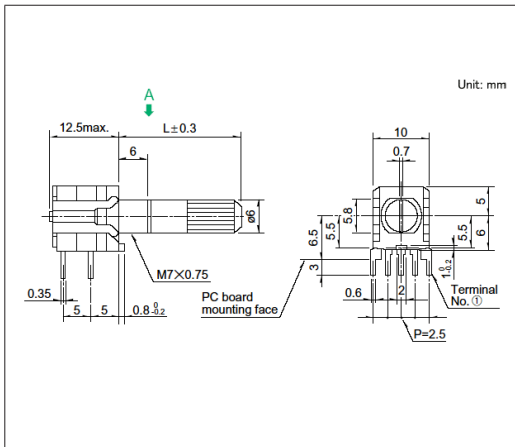

■ Mounting Hole Dimensions

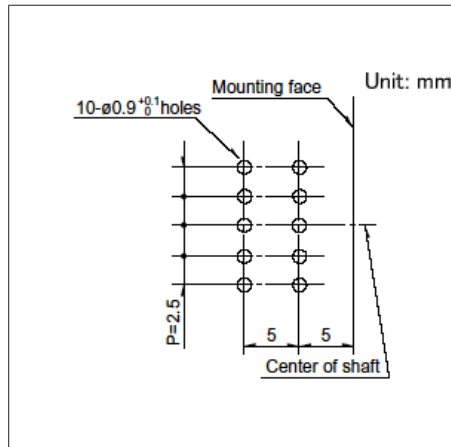

■ Circuit Diagram

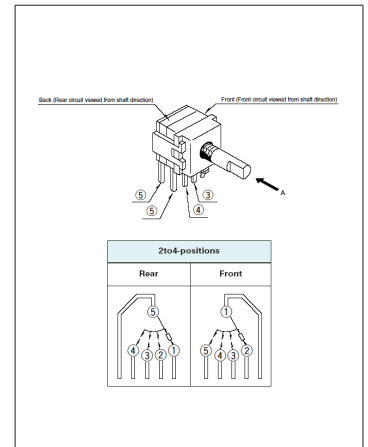

Viewed from direction A in the dimensions.

1. Viewed from direction A.
2. For positions 4, 1 section consists of 2-poles.

Drawing No.6

■ Dimensions

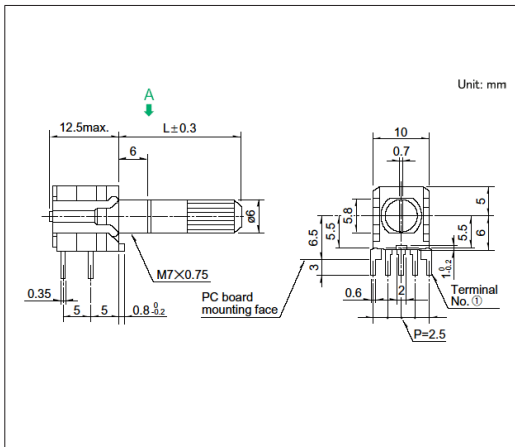

■ Mounting Hole Dimensions

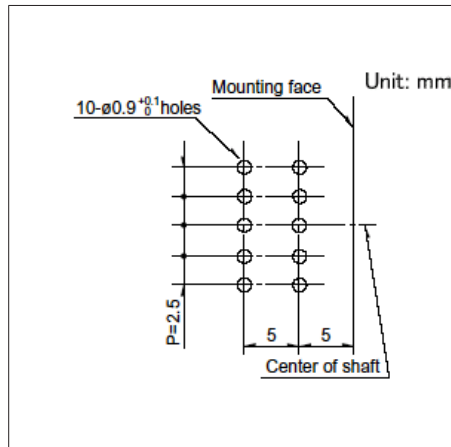

■ Circuit Diagram

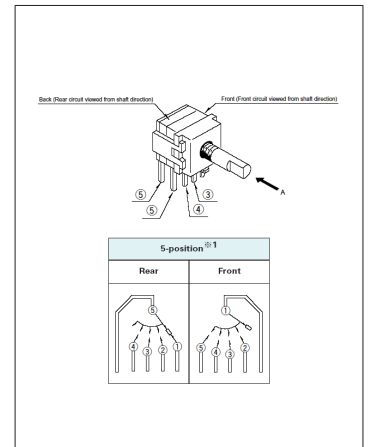

Viewed from direction A in the dimensions.

1. Viewed from direction A.
2. Circuit steps are 2 to 5 positions at front and 1 to 4 positions at rear.
3. It is necessary external wiring of common terminals.
4. For positions 5, 1 section consists of 1-pole.

6-positions Horizontal Type  
SRBM Series

Drawing No.7

■ Dimensions

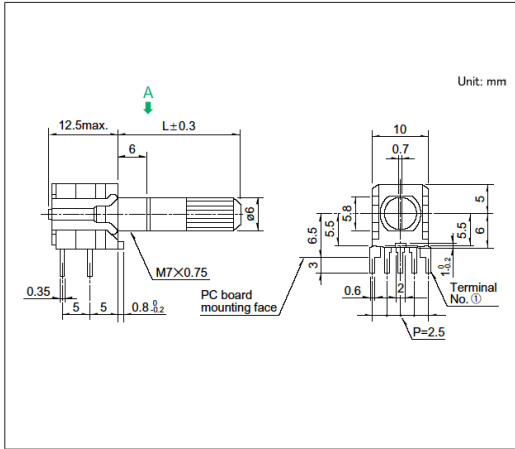

■ Mounting Hole Dimensions

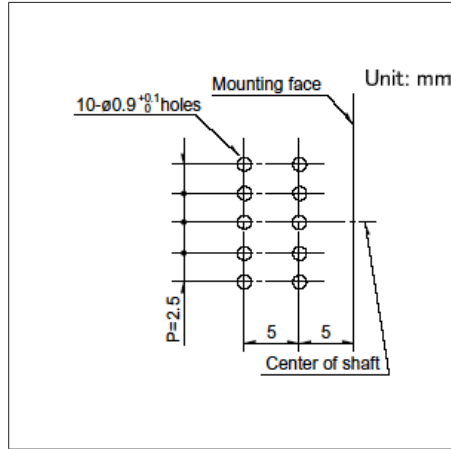

■ Circuit Diagram

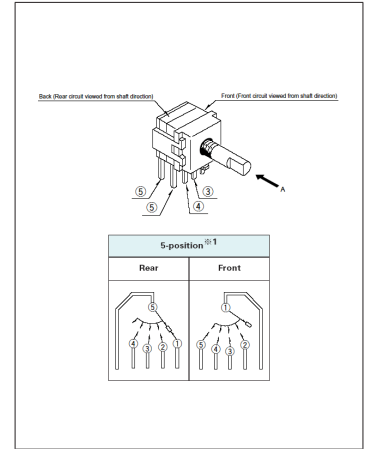

Viewed from direction A in the dimensions.

1. Viewed from direction A.
2. Circuit steps are 2 to 5 positions at front and 1 to 4 positions at rear.
3. It is necessary external wiring of common terminals.
4. For positions 5, 1 section consists of 1-pole.

Drawing No.8

■ Dimensions

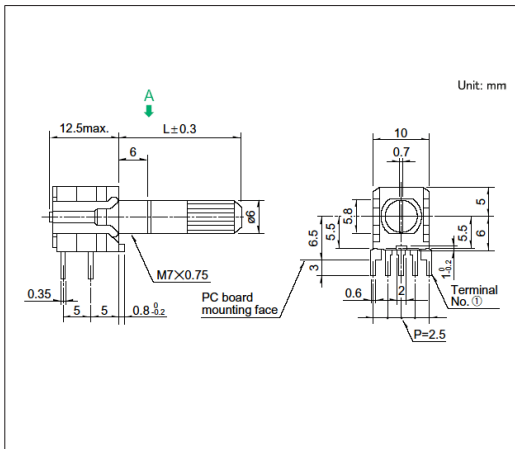

■ Mounting Hole Dimensions

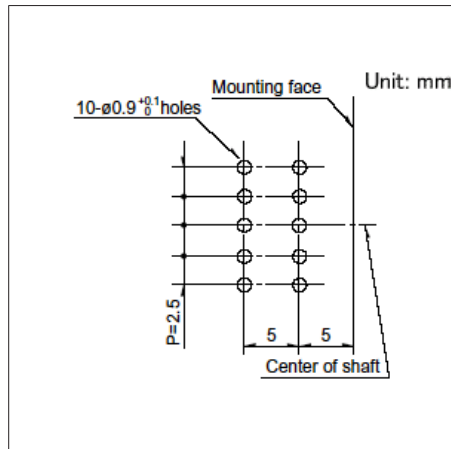

■ Circuit Diagram

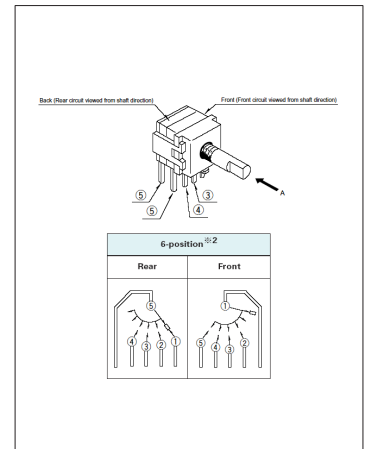

Viewed from direction A in the dimensions.

1. Viewed from direction A.
2. Circuit steps are 3 to 6 positions at front and 1 to 4 positions at rear.
3. It is necessary external wiring of common terminals.
4. For positions 6, 1 section consists of 1-pole.

6-positions Horizontal Type  
SRBM Series

Drawing No.9

■ Dimensions

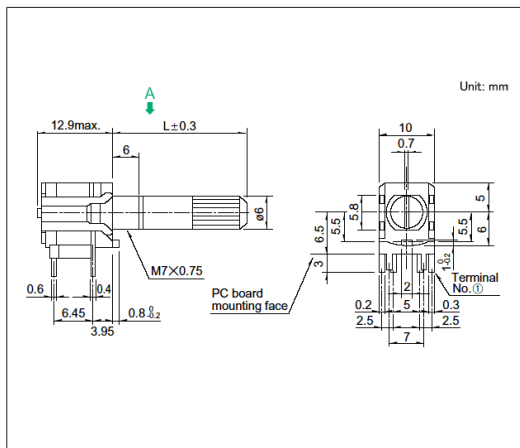

■ Mounting Hole Dimensions

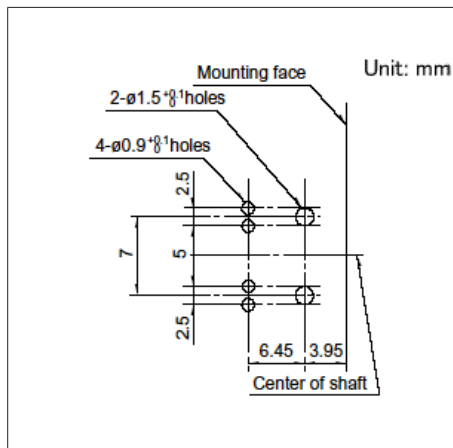

■ Circuit Diagram

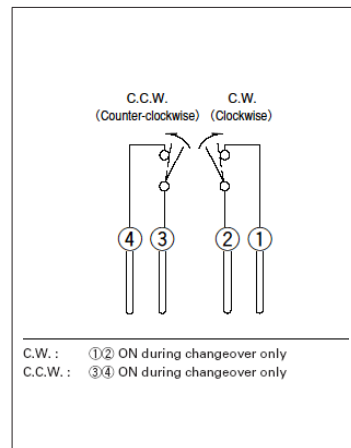

Viewed from direction A in the dimensions.

Pulse Switch

Drawing No.10

■ Dimensions

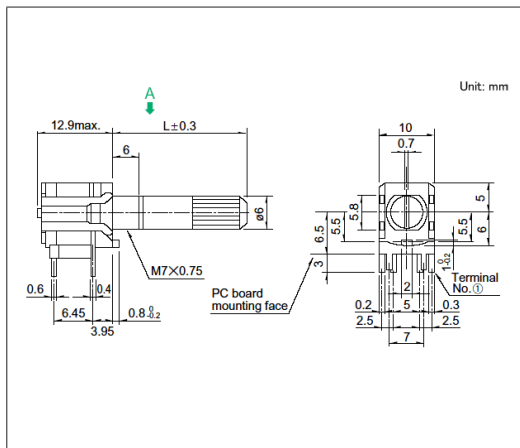

■ Mounting Hole Dimensions

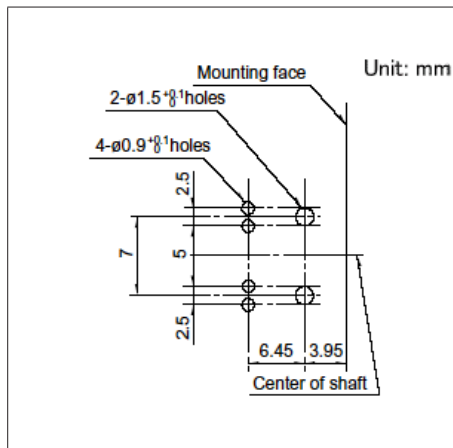

■ Circuit Diagram

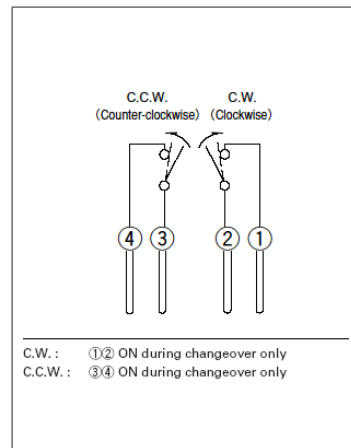

Viewed from direction A in the dimensions.

Pulse Switch

## Switches Rotary Switches

8-positions Low-profile Vertical Type  
**SRBV Series**

Contributes to set design flexibility with a body height of 7.5mm and thin-profile design.

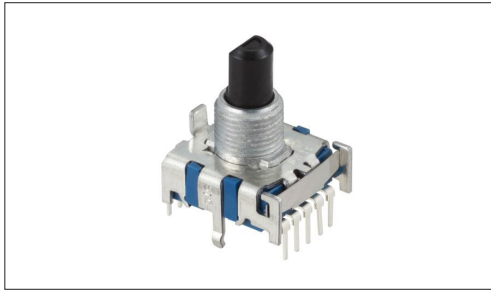

- Rating (max.)/(min.) (Resistive load): 0.3A 16V DC/50 $\mu$ A 3V DC
- Contact resistance (Initial performance/After lifetime):  
50m $\Omega$  max./150m $\Omega$  max.
- Operating life without load: 10,000 cycles 100m $\Omega$  max.
- Operating life with load (at max. rated load): 10,000 cycles 150m $\Omega$  max.

Applications: Home: Major home appliances

## ■ Product List

Products No.	Poles	Positions	Changeover angle	Changeover timing	Rotational torque	Actuator configuration	Actuator length	Dimensions (WxDxH) (mm)	Automotive	Drawing No.
SRBV131803	1	3	30 $\pm$ 3°	Non shorting	30 $\pm$ 15mN·m	Flat	L: 15mm	16.2 $\times$ 18.5 $\times$ 7.5	—	1
SRBV131502	1	3	30 $\pm$ 3°	Non shorting	30 $\pm$ 15mN·m	Flat	L: 20mm	16.2 $\times$ 18.5 $\times$ 7.5	—	2
SRBV141404	1	4	30 $\pm$ 3°	Non shorting	30 $\pm$ 15mN·m	Flat	L: 15mm	16.2 $\times$ 18.5 $\times$ 7.5	—	3
SRBV141201	1	4	30 $\pm$ 3°	Non shorting	30 $\pm$ 15mN·m	Flat	L: 20mm	16.2 $\times$ 18.5 $\times$ 7.5	—	4
SRBV151102	1	5	30 $\pm$ 3°	Non shorting	30 $\pm$ 15mN·m	Flat	L: 15mm	16.2 $\times$ 18.5 $\times$ 7.5	—	5
SRBV150901	1	5	30 $\pm$ 3°	Non shorting	30 $\pm$ 15mN·m	Flat	L: 20mm	16.2 $\times$ 18.5 $\times$ 7.5	—	6
SRBV160803	1	6	30 $\pm$ 3°	Non shorting	30 $\pm$ 15mN·m	Flat	L: 15mm	16.2 $\times$ 18.5 $\times$ 7.5	—	7
SRBV170701	1	7	30 $\pm$ 3°	Non shorting	30 $\pm$ 15mN·m	Flat	L: 15mm	16.2 $\times$ 18.5 $\times$ 7.5	—	8
SRBV170501	1	7	30 $\pm$ 3°	Non shorting	30 $\pm$ 15mN·m	Flat	L: 20mm	16.2 $\times$ 18.5 $\times$ 7.5	—	9
SRBV181004	1	8	30 $\pm$ 3°	Non shorting	30 $\pm$ 15mN·m	Flat	L: 15mm	16.2 $\times$ 18.5 $\times$ 7.5	—	10

## ⚠ Note

1. This catalog shows only outline specifications. When using the products, please obtain formal specifications for supply.
2. Please place purchase orders per minimum order unit (integer).

## ■ Packing Specifications

Tray

Number of packages(pcs.)		Export package measurements (mm)
1 case / Japan	1 case / export packing	
165	330	400 x 270 x 185



8-positions Low-profile Vertical Type  
SRBV Series

Drawing No.4

■ Dimensions

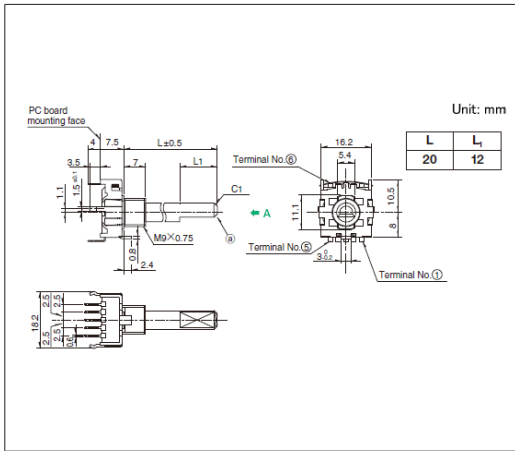

■ Mounting Hole Dimensions

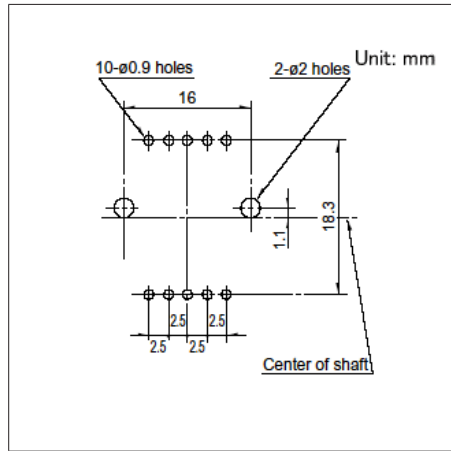

■ Circuit Diagram and Dummy Terminals

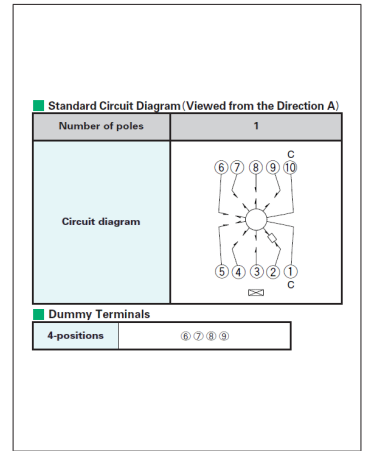

Viewed from direction A in the dimensions.

Drawing No.5

■ Dimensions

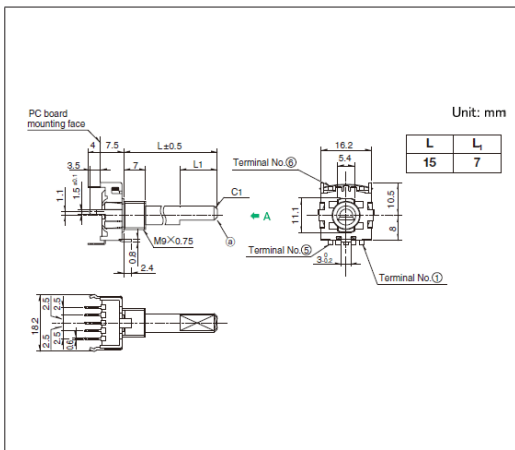

■ Mounting Hole Dimensions

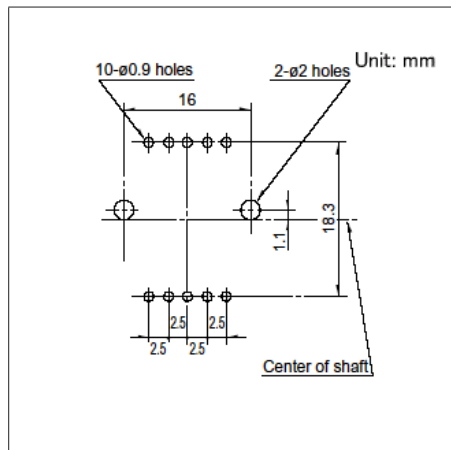

■ Circuit Diagram and Dummy Terminals

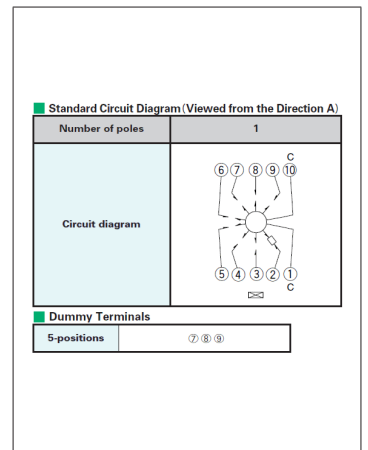

Viewed from direction A in the dimensions.

Drawing No.6

■ Dimensions

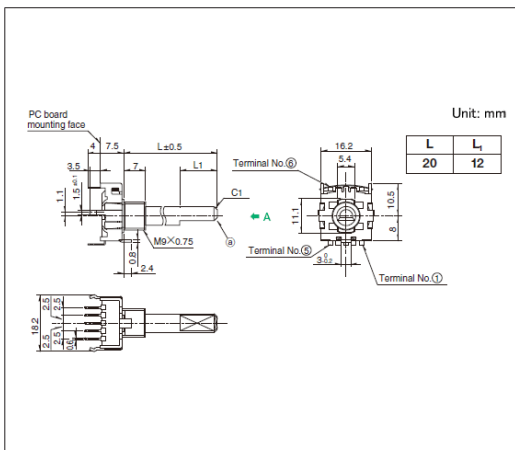

■ Mounting Hole Dimensions

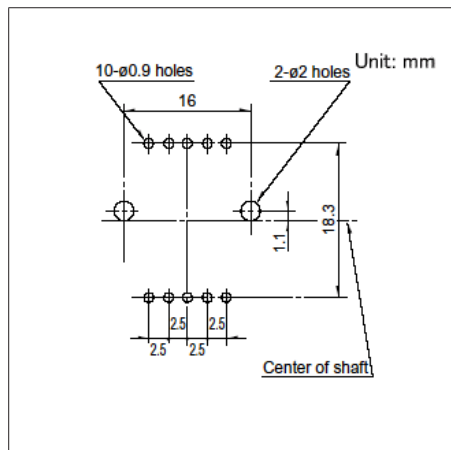

■ Circuit Diagram and Dummy Terminals

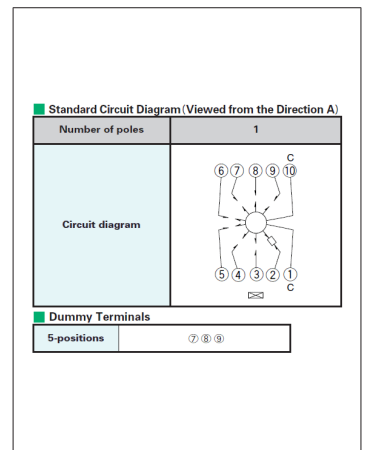

Viewed from direction A in the dimensions.



8-positions Low-profile Vertical Type  
**SRBV Series**

**Drawing No.10**

■ Dimensions

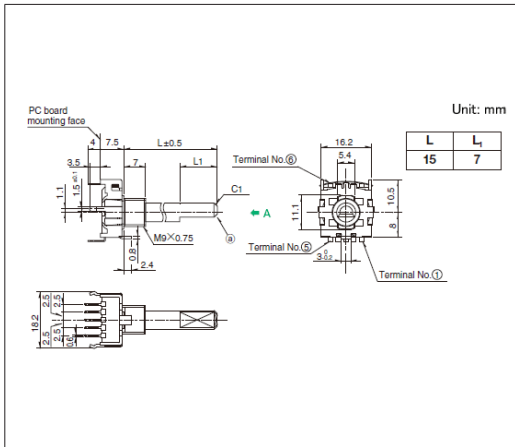

■ Mounting Hole Dimensions

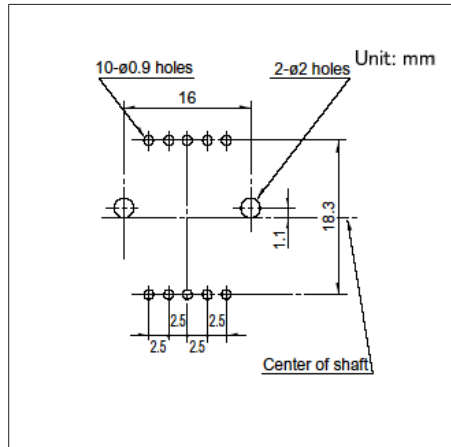

■ Circuit Diagram

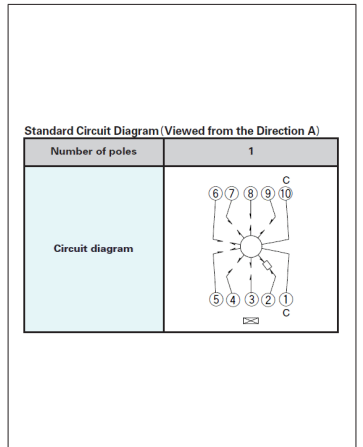

Viewed from direction A in the dimensions.

## Rotary Switches / Soldering Conditions

### ■ Example of Reflow Soldering Condition

1. Heating method: Double heating method with infrared heater.
2. Temperature measurement: Thermocouple  $\phi 0.1$  to  $0.2$  CA (K) or CC (T) at soldering portion (copper foil surface) .  
A heat resisting tape should be used for fixed measurement.

#### 3. Temperature profile

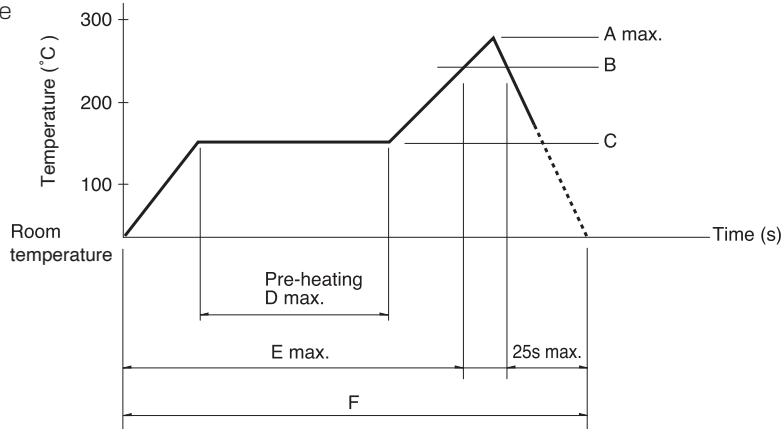

Series (Reflow type)	A (°C) 3s max.	B (°C)	C (°C)	D (s)	E (s)	F (s)
SRBQ	250	200	150±5	80 to 100	—	—

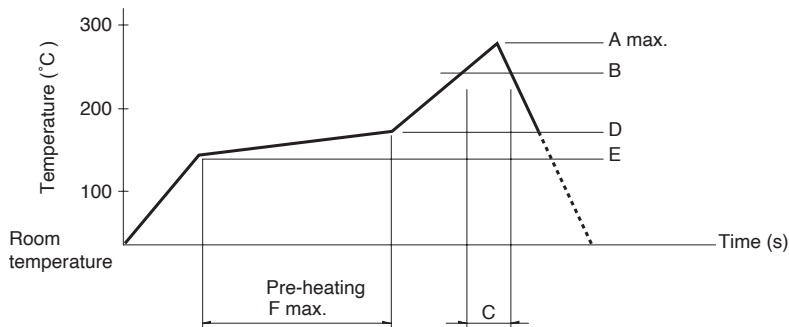

Series (Reflow type)	A (°C) 3s max.	B (°C)	C (s)	D (°C)	E (°C)	F (s)
SRBD	260	230	40	180	150	120



1. The condition mentioned above is the temperature on the mounting surface of a PC board. There are cases where the PC board's temperature greatly differs from that of the switch, depending on the PC board's material, size, thickness, etc. The above-stated conditions shall also apply to switch surface temperatures.
2. Soldering conditions differ depending on reflow soldering machines. Prior verification of soldering condition is highly recommended.

### ■ Reference for Hand Soldering

Series	Soldering temperature	Soldering time
SRBQ, SRBM, SRBV	350±10°C	3+1/0s
SRBQ (Reflow type)	350±5°C	3s max.

### ■ Reference for Dip Soldering

(For PC board terminal types)

Series	Items		Dip soldering	
	Preheating temperature	Preheating time	Soldering temperature	Duration of immersion
SRBM	100°C max.	60s max.	260±5°C	5s max.
SRBV	—	—	260±5°C	10±1s
SRBQ	—	—	260±5°C	5±1s

## Rotary Switches / Cautions

1. Applying load to terminals during soldering under certain conditions may cause deformation and electrical property degradation.
2. Avoid use of water-soluble soldering flux, since it may corrode the switches.
3. Check and conform to soldering requirements under actual mass production conditions.
4. When soldering twice, wait until the first soldered portion cools to normal temperature. Continuous heating will deform the external portions, loosen or dislodge terminals, or may deteriorate their electrical characteristics.
5. Flux from around and above the PC board should not adhere to the switches.
6. After mounting the switches, if you intend to put the board into an oven in order to harden adhesive for other parts, please consult with us.
7. If you use a through-hole PC board or a PC board thinner or thicker than the recommendation, there may be greater heat stress. Verify the soldering conditions thoroughly before use.
8. Solder the switches with detent at the detent position. Soldering switches fixed at the center of the detent may deform the detent mechanisms.
9. No cleaning.
10. Protect small and thin switches from external forces in the set mounting process.
11. Tighten the mounting screws by applying the specified torque. Tightening with larger torque than the specified one will result in malfunction or breakage of screws.
12. Insert these switches to the specified mounting surface and mount them horizontally. If not mounted horizontally, these switches will malfunction.
13. The products are designed and manufactured for direct current resistance. Contact us for use of other resistances such as inductive (L) or capacitive (C).
14. The switch will break if you apply a greater stress than that specified. Take great care not to let the switch be subject to greater stress than specified.
15. Use of the switches in a dusty environment may lead to dusts entering through the openings and cause imperfect contact or malfunction. Take this into account for set design.
16. Corrosive gas if generated by peripheral parts of a set, malfunction such as imperfect contact may occur. Thorough investigation shall be required beforehand.
17. Storage  
Store the products as delivered at normal temperature and humidity, out of direct sunlight and away from corrosive gases. Use them as soon as possible and no later than six months after delivery.  
Once the seal is broken, use them as soon as possible.