

COMET

Features

COMET is Automotive ASIC, includes capacitance sensing circuit.

- Capacitance sensing Function
 - Absolute self-capacitance sensing / Mutual capacitance sensing
 - Capacitance sensing circuit : 16 channels (Multi bit 2nd order $\Delta \Sigma$ ADC)
 - Number of sensor electrodes : 64 port (One measurement channel has four ports)
 - Sensor drive frequency : 58.33 / 70 / 87.5 kHz (Sine wave)
 - Oversampling Ratio : 60
 - Number of samples : 120 to 4080 times
- Power
 - Supply voltage : 5.0V (4.75V to 5.5V)
 - Host Interface voltage : 3.3V or 5.0V
- Current Consumption
 - Measuring (self-capacitance , 16-channel enabled) : 30 mA (TYP.)
 - Suspend mode : 530 uA (TYP.)
- Package : QFP 100 pin (14mm x 14mm x 1.6mm)
- Interface
 - SPI (MODE 0) : 4MHz Max
- Oscillation circuit
 - 42MHz : System Clock Source
- Reliability test standards : AEC-Q100 Grade2 (-40°C to +105°C)

1 Overview

1.1 Block diagram

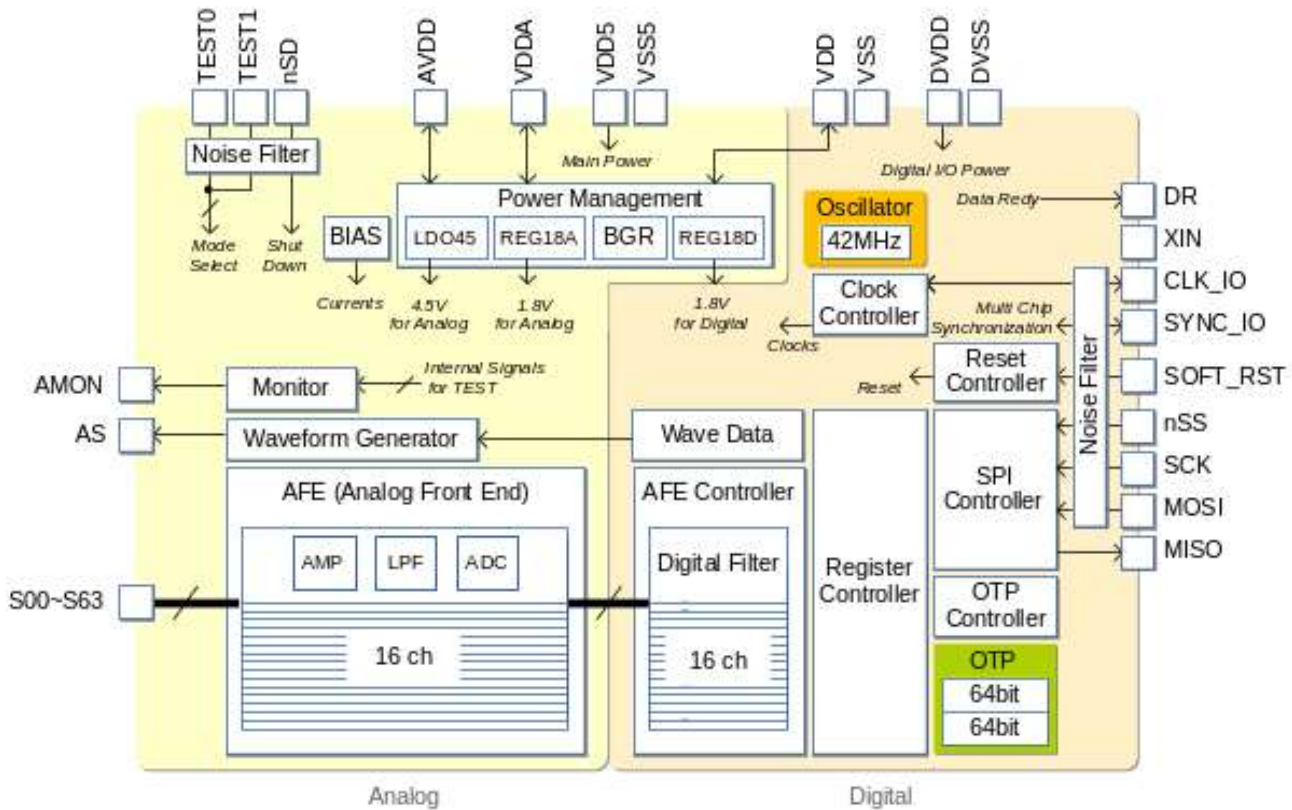

Figure 1-1 : Block Diagram

1.2 Block Overview

Table 1-1 : Block Overview

Block	Description
OTP	One Time Programmable Memory
Oscillator	Clock Generation Circuit (42MHz)
BGR	Band Gap Reference (1.2V)
REG18D	Low Dropped Out (LDO) Regulator (1.8V) for Digital
REG18A	Low Dropped Out (LDO) Regulator (1.8V) for Analog
LDO45	Low Dropped Out (LDO) Regulator (4.5V) for Analog
Monitor	Internal Node Monitor
BIAS	Reference Current Source
AMP	Convert capacitance to voltage
LPF	Low Pass Filter
ADC	Analog Digital Converter (Multi bit 2nd order $\Delta \Sigma$ ADC)
Waveform Generator	Sine wave Generation

2 Pin

2.1 Pin Assignment

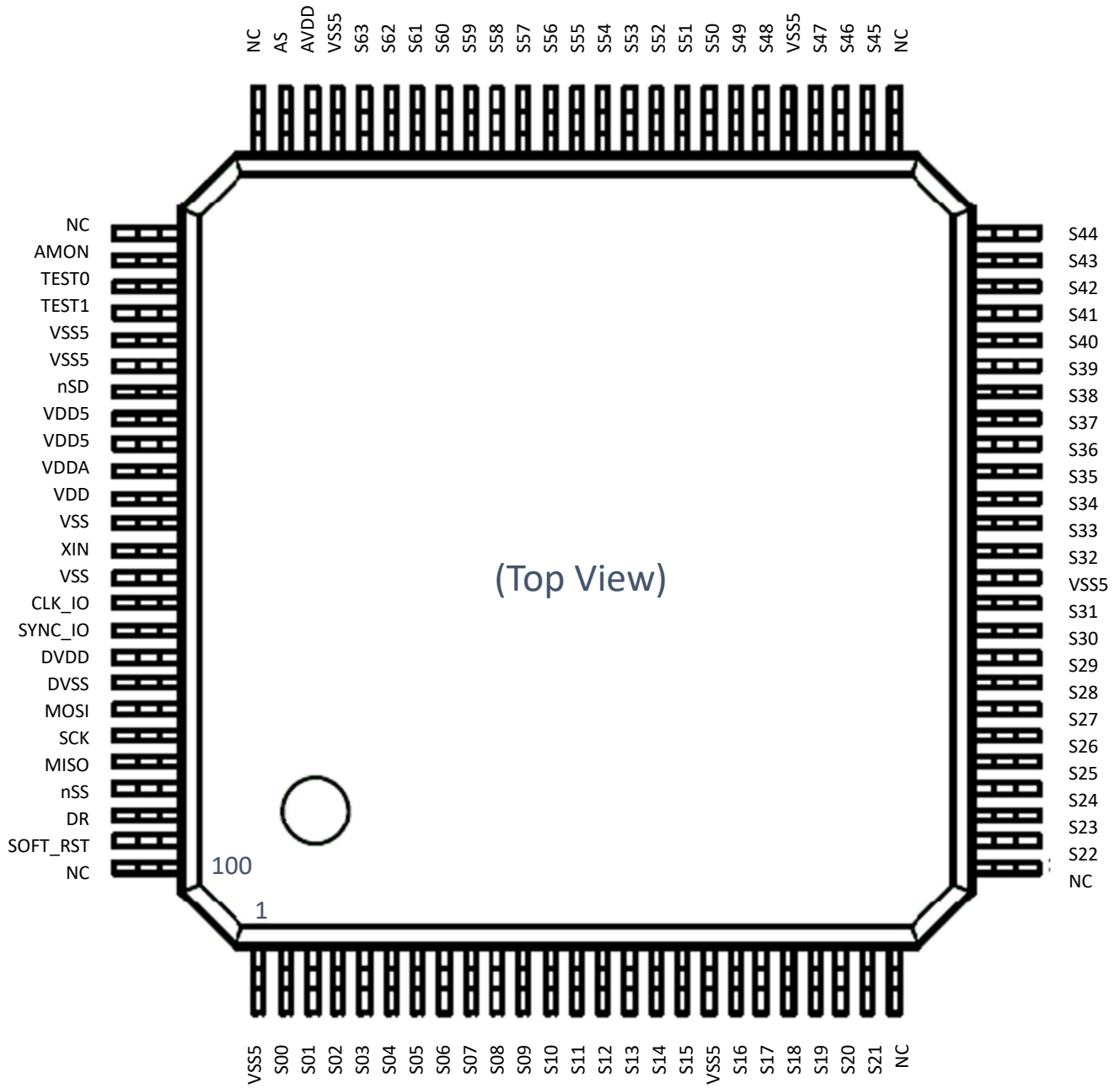

Figure 2-1 : Pin Assignment

2.2 Pin List

Table 2-1 : Pin List

No.	Name	Type*	Power Domain	Description	Note
1	VSS5	Power	AVDD	GND	Supply ground
2	S00	A in/out		Sensor for A/D [0] or Shield	Connect to sensor electrode
3	S01			Sensor for A/D [1] or Shield	
4	S02			Sensor for A/D [2] or Shield	
5	S03			Sensor for A/D [3] or Shield	
6	S04			Sensor for A/D [4] or Shield	
7	S05			Sensor for A/D [5] or Shield	
8	S06			Sensor for A/D [6] or Shield	
9	S07			Sensor for A/D [7] or Shield	
10	S08			Sensor for A/D [8] or Shield	
11	S09			Sensor for A/D [9] or Shield	
12	S10			Sensor for A/D [10] or Shield	
13	S11			Sensor for A/D [11] or Shield	
14	S12			Sensor for A/D [12] or Shield	
15	S13			Sensor for A/D [13] or Shield	
16	S14			Sensor for A/D [14] or Shield	
17	S15			Sensor for A/D [15] or Shield	
18	VSS5	Power	AVDD	GND	Supply ground
19	S16	A in/out		Sensor for A/D [0] or Shield	Connect to sensor electrode
20	S17			Sensor for A/D [1] or Shield	
21	S18			Sensor for A/D [2] or Shield	
22	S19			Sensor for A/D [3] or Shield	
23	S20			Sensor for A/D [4] or Shield	
24	S21	Sensor for A/D [5] or Shield			
25	NC	-	-	-	Supply ground or Leave open
26	NC	-	-	-	Supply ground or Leave open
27	S22	A in/out	AVDD	Sensor for A/D [6] or Shield	Connect to sensor electrode
28	S23			Sensor for A/D [7] or Shield	
29	S24			Sensor for A/D [8] or Shield	
30	S25			Sensor for A/D [9] or Shield	
31	S26			Sensor for A/D [10] or Shield	
32	S27			Sensor for A/D [11] or Shield	
33	S28			Sensor for A/D [12] or Shield	
34	S29			Sensor for A/D [13] or Shield	
35	S30			Sensor for A/D [14] or Shield	
36	S31			Sensor for A/D [15] or Shield	
37	VSS5	Power	AVDD	GND	Supply ground
38	S32	A in/out		Sensor for A/D [0] or Shield	Connect to sensor electrode
39	S33			Sensor for A/D [1] or Shield	
40	S34			Sensor for A/D [2] or Shield	
41	S35			Sensor for A/D [3] or Shield	
42	S36			Sensor for A/D [4] or Shield	
43	S37			Sensor for A/D [5] or Shield	
44	S38			Sensor for A/D [6] or Shield	
45	S39			Sensor for A/D [7] or Shield	
46	S40			Sensor for A/D [8] or Shield	
47	S41			Sensor for A/D [9] or Shield	
48	S42			Sensor for A/D [10] or Shield	
49	S43			Sensor for A/D [11] or Shield	
50	S44			Sensor for A/D [12] or Shield	

* A : Analog , D : Digital

No.	Name	Type*	Power Domain	Description	Note	
51	NC	-	-	-	Supply ground or Leave open	
52	S45	A in/out	AVDD	Sensor for A/D [13] or Shield	Connect to sensor electrode	
53	S46			Sensor for A/D [14] or Shield		
54	S47			Sensor for A/D [15] or Shield		
55	VSS5	Power		GND	Supply ground	
56	S48	A in/out	AVDD	Sensor for A/D [0] or Shield	Connect to sensor electrode	
57	S49			Sensor for A/D [1] or Shield		
58	S50			Sensor for A/D [2] or Shield		
59	S51			Sensor for A/D [3] or Shield		
60	S52			Sensor for A/D [4] or Shield		
61	S53			Sensor for A/D [5] or Shield		
62	S54			Sensor for A/D [6] or Shield		
63	S55			Sensor for A/D [7] or Shield		
64	S56			Sensor for A/D [8] or Shield		
65	S57			Sensor for A/D [9] or Shield		
66	S58			Sensor for A/D [10] or Shield		
67	S59			Sensor for A/D [11] or Shield		
68	S60			Sensor for A/D [12] or Shield		
69	S61			Sensor for A/D [13] or Shield		
70	S62			Sensor for A/D [14] or Shield		
71	S63	Sensor for A/D [15] or Shield				
72	VSS5	Power		GND	Supply ground	
73	AVDD	Power(out)		Regulator output for 4.5V analog	Connect to capacitor	
74	AS	A in/out	VDD5	Active shield	Connect to shield plane	
75	NC	-	-	-	Supply ground or Leave open	
76	NC	-	-	-	Supply ground or Leave open	
77	AMON	A out	VDD5	Analog monitor	Leave open	
78	TEST0	D in		Test mode select	Leave open	
79	TEST1	D in		Test mode select	Leave open	
80	VSS5	Power		GND	Supply ground	
81	VSS5					
82	nSD	D in		Shutdown set	"H": Normal or "L": Shutdown	
83	VDD5	Power		Main power	Supply main power	
84	VDD5					
85	VDDA	Power(out)		Regulator output for 1.8V analog	Connect to capacitor	
86	VDD	Power(out)		Regulator output for 1.8V digital	Connect to capacitor	
87	VSS	Power	GND for digital	Supply ground		
88	XIN	A in/out	External clock input	Leave open		
89	VSS	Power	GND for digital	Supply ground		
90	CLK_IO	D in/out	Clock signal in/out			
91	SYNC_IO	D in/out	Synchronous signal in/out			
92	DVDD	Power	DVDD	Power for I/F	Supply IO power	
93	DVSS	Power		GND for I/F	Supply ground	
94	MOSI	D in		SPI slave input		
95	SCK	D in		SPI clock		
96	MISO	D out		SPI slave output		
97	nSS	D in		SPI slave select		
98	DR	D out		Output data ready		
99	SOFT_RST	D in		Register reset for TEST	Leave open	
100	NC	-		-	-	Supply ground or Leave open

* A : Analog , D : Digital

3 Package Information

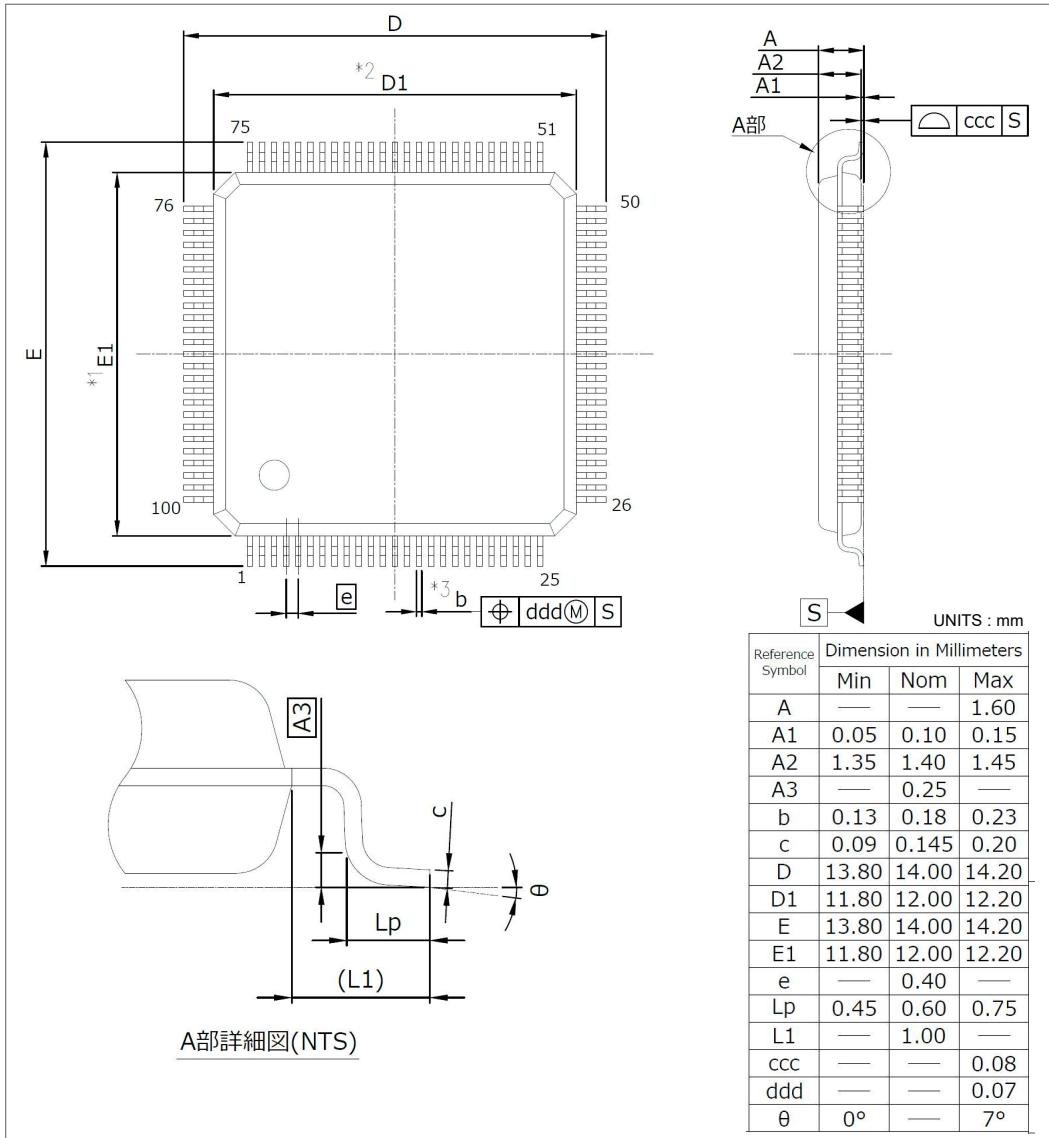

Figure 3-1 : Package Sizes

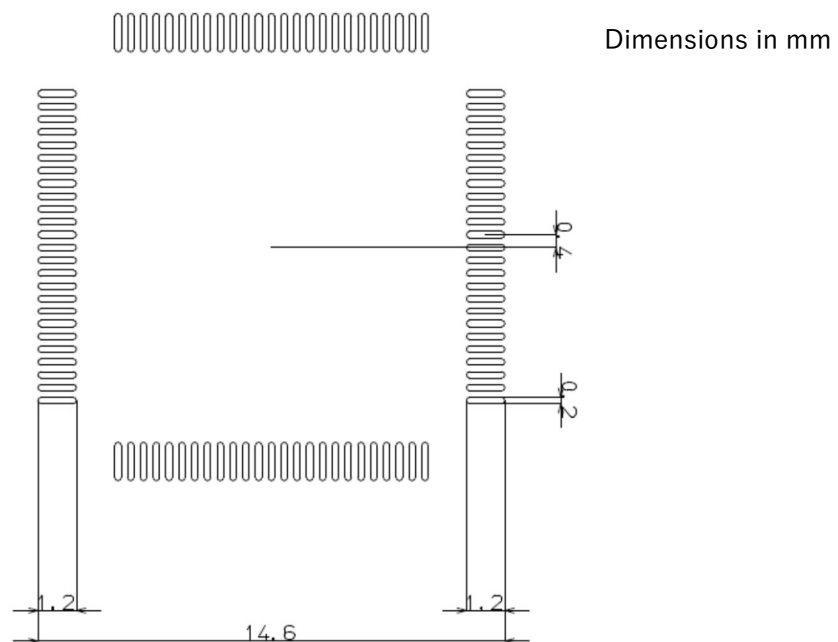

Figure 3-2 : Recommended Land Patterns

4 Reference Schematic

Table 4-1 : Recommended external parts

Parameter	Symbol	Unit	Condition	Min.	Typ.	Max.
VDD5 bypass capacitor	C1	uF	-	0.9	1.0	-
DVDD bypass capacitor	C2	uF	-	0.09	0.1	-
VDD bypass capacitor	C3	uF	-	0.9	1.0	1.2 *
VDDA bypass capacitor	C4	uF	-	0.9	1.0	1.2 *
AVDD bypass capacitor	C5	uF	-	0.9	1.0	1.2 *

* Possible to connect small capacitance capacitor parallel, as high frequency noise solution

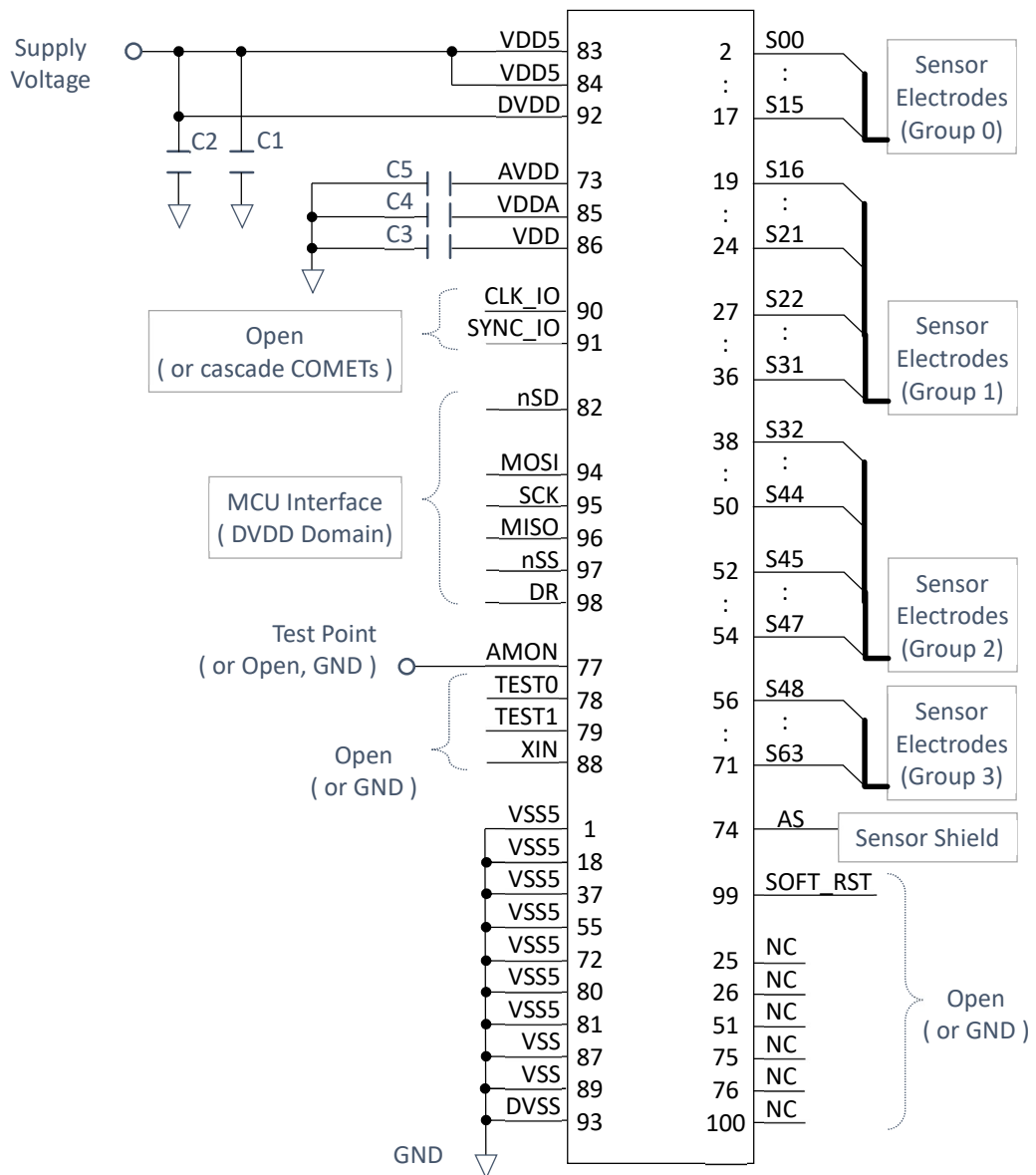

Figure 4-1 : Reference circuit diagram

5 Sensor Specification

5.1 Absolute Self-Capacitance Sensing

Table 5-1 : Sensor Spec. (Absolute Self-Capacitance sensing)

Parameter	Symbol	Unit	Condition	Min.	Typ.	Max.
Sensing Capacitance	Crg	pF	-	0.0036	0.17	3.0
Shield leak Capacitance	Crgl	pF	-	2	-	10
Capacitance between RX-AS	Crs	pF	-	40	70	130
Capacitance between AS-GND	Csg	pF	-	500	1200	1500
RX Electrode Current Path Resistance	Rrt	k Ω	-	-	-	30*
Electrode Sheet Resistance	-	Ω/\square	-	-	-	150

* Depends on sensor RC distribution and Crg size/position. Requires confirmation at product configuration

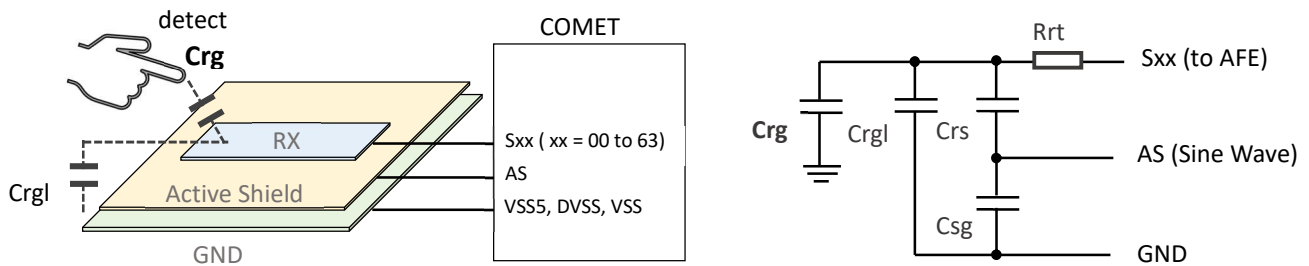

Figure 5-1 : Sensor Model (Absolute Self-Capacitance sensing)

5.2 Mutual Capacitance Sensing

Table 5-2 : Sensor Spec. (Mutual Capacitance Sensing)

Parameter	Symbol	Unit	Condition	Min.	Typ.	Max.
Sensing capacitance (Offset)	Ctr	pF		0.5	1.0	3.0
Sensing capacitance (Change)	Δ Ctr	pF		-0.12	-0.04	-0.02
Capacitance between RX to GND (or AS)	Crg	pF	AS pin = MVREF (DC Voltage)	15	30	130
Capacitance between TX to GND (or AS)	Ctg	pF	AS pin = MVREF (DC Voltage)	15	30	130
Current path resistance of RX electrode	Rrr	k Ω	-	-	-	30*
Current path resistance of TX electrode	Rtt	k Ω	-	-	-	30*
Electrode sheet resistance	-	Ω/\square	-	-	-	150

* Depends on sensor RC distribution and Ctr size/position. Requires confirmation at product configuration

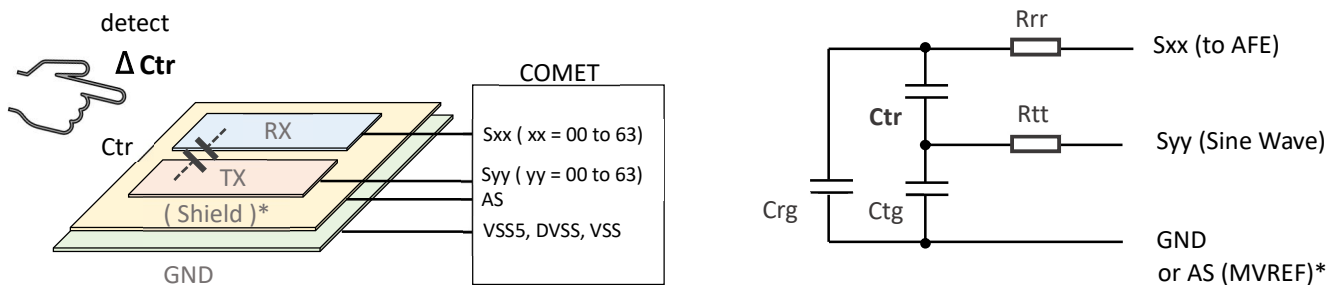

* Shield electrode sometimes reduces the diffusion of A/D results. It depends on sensor location and configuration.

In this case, please follow Csg (AS-GND Capacitance) specification.

Figure 5-2 : Sensor Model (Mutual Capacitance Sensing)

6 Electrical Characteristics

6.1 Absolute Maximum Ratings

Table 6-1 : Absolute Maximum Ratings

Item	Symbol	Unit	Condition	Min.	Max.
Supply Voltage	VDD5	V	-	-0.3	6
Interface Voltage	DVDD	V	-	-0.3	6
Input Voltage	V _{A1N}	V	-	-0.3	VDD5+0.3
	V _{D1N}	V	-		DVDD+0.3
Storage temperature	T _{stg}	°C	-	-55	125
Allowable power dissipation (25°C)	P _d	mW	$\theta_{ja}=36.3^{\circ}\text{C}/\text{W}$ (JEDEC 4-layer board)	-	2750
Allowable power dissipation (105°C)					550

6.2 Operating Conditions

Table 6-2 : Operating Conditions

Item	Symbol	Unit	Condition	Min.	Typ.	Max.
Supply Voltage	VDD5	V	-	4.75	5	5.5
Interface Voltage	DVDD	V	-	2.7	3.3	VDD5
Operating Temperature	T _{opr} (T _a)	°C	-	-40	25	105
Operating Temperature	T _{VDD5_RISE}	ms	-	0.1	-	100
SPI Setup Time*1	T _{SPI_EN}	ms	-	25	-	-
Shutdown pulse width*2	T _{nSD_WDT}	us	-	20	-	-

*1 nSD pin="L" → "H" Edge to First SPI Command (nSS="L")

*2 nSD pin="H" → "L" Edge to nSD pin="L" → "H" Edge